

4500 TVC

Trolling valve control

4500 TVC permits to command mechanically the trolling valve



The command station is a «dual lever control»: one lever (red) controls the engine speed and the second lever (black) controls the propeller pitch. This allows an accurate and precise fine tuning of the boat speed.



The command station is a «dual lever control»: one lever controls both the engine speed and the gearbox and the second lever controls the mechanical trolling valve.

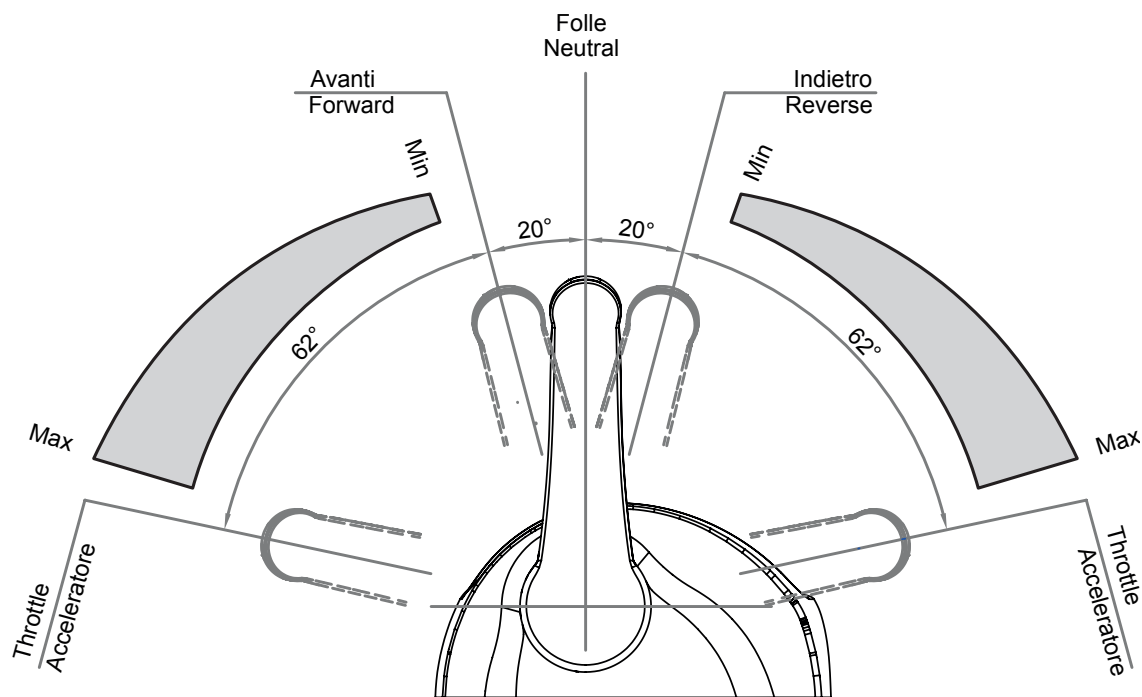

Funzionamento leva di comando motore e invertitore
Functioning of the engine and gearbox command lever

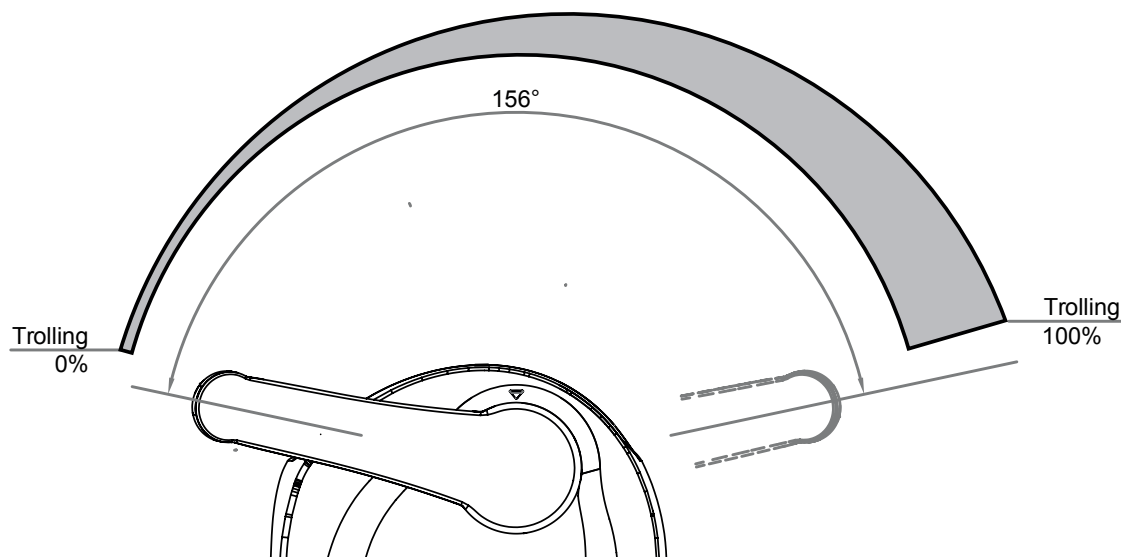

Funzionamento leva di comando trolling
Functioning of the trolling command lever

Flexball Italiana S.r.l.

Via San Luigi 13/A - 10043 Orbassano (To) - Italy

Tel 0039.011 90.38.900 - Fax 0039.011 90.38.747

info@flexballitaliana.com

www.flexballitaliana.com

FLEXBALL
ITALIANA

WR CONTROLS GROUP

