

# 1600

## Mechanical control lever

It is made with an aluminium alloy body

Push-pull cable exits at 45 degrees with respect to the lever. It is used for the command of gears, stabilizers, brush cutters, agricultural machineries and hydraulic distributors in general.

### SPECIFICATION

- Possibility to mount side by side for multi axles applications
- Cable's stroke: +/- 16 mm
- 300 N maximum working load

### CODES

Version	Code
Basic lever without spring	1600
With return to centre spring (self centering)	1600.01
With syringe to lock the lever in the centre	1600.02

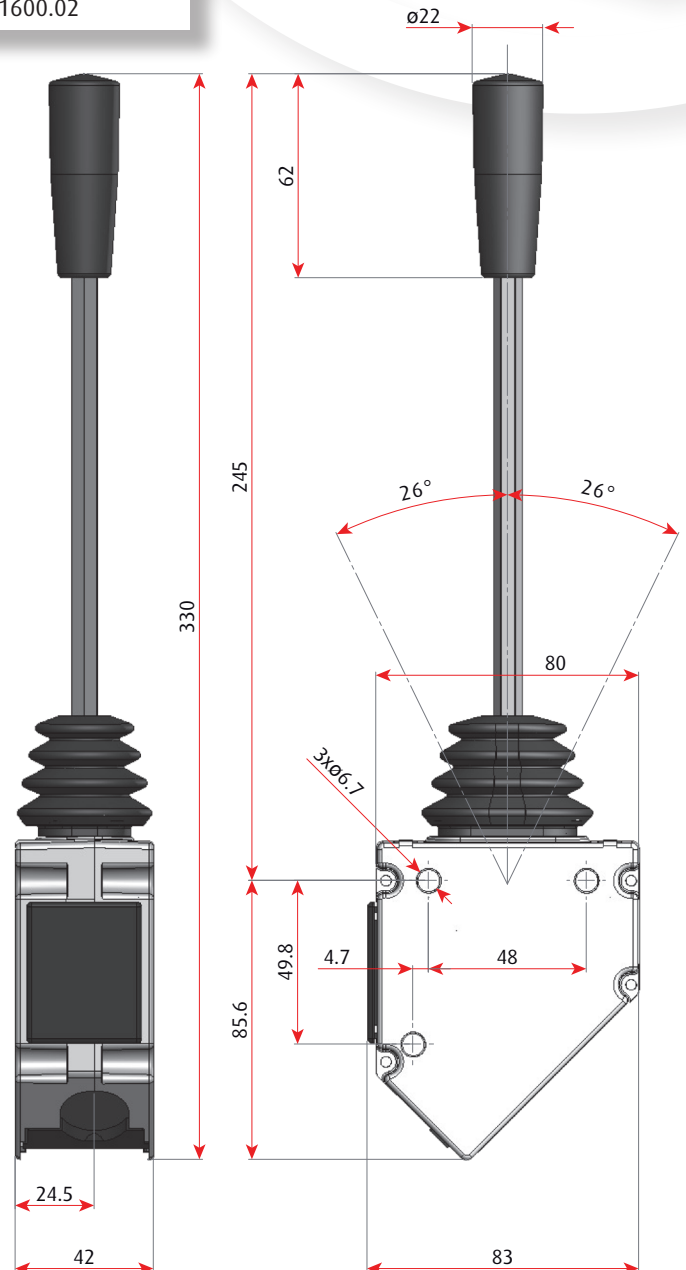

PUSH-PULL CABLES WHICH FIT WITH LEVER 1600

- The end fittings are represented with the cable at mid stroke position

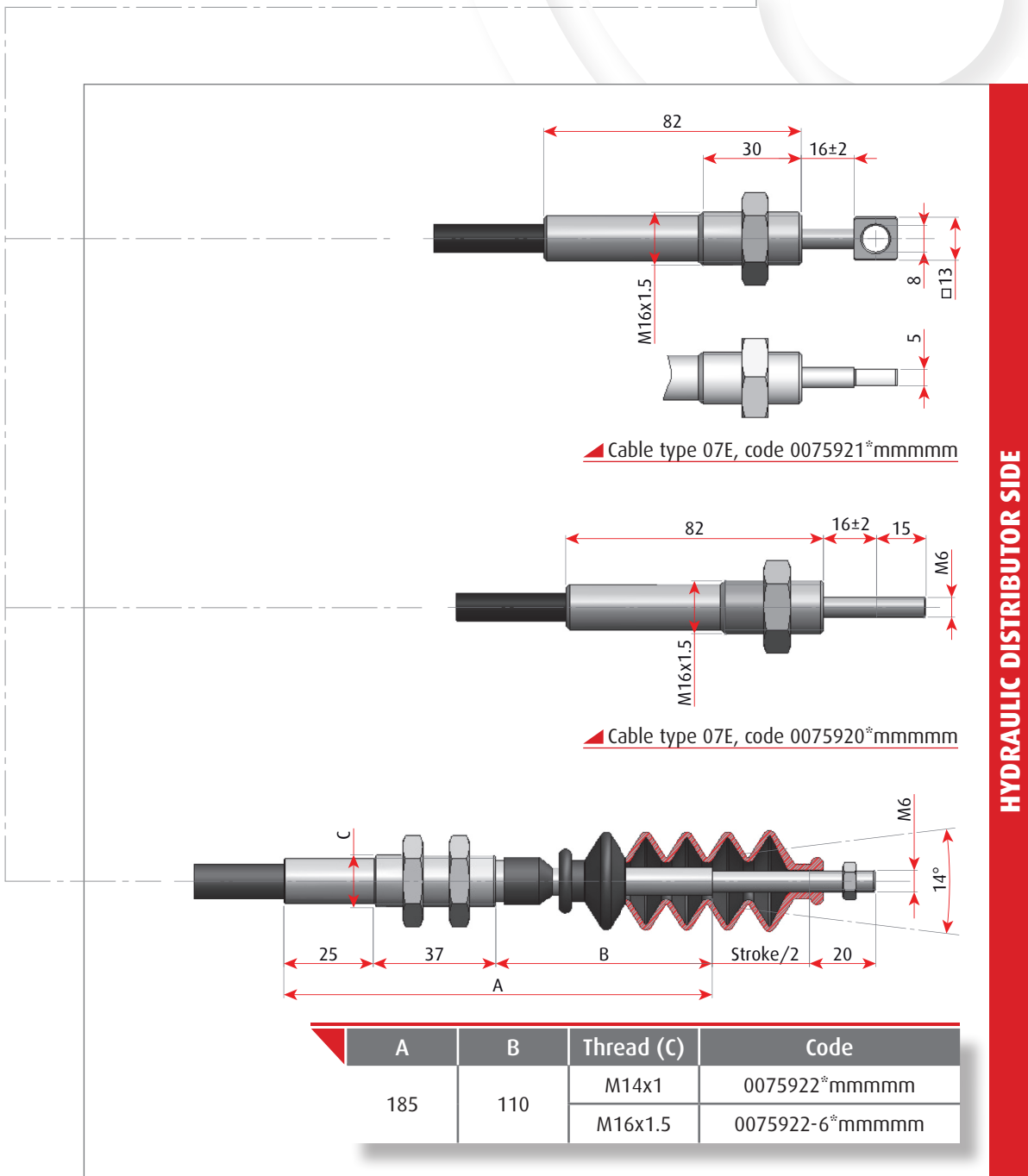
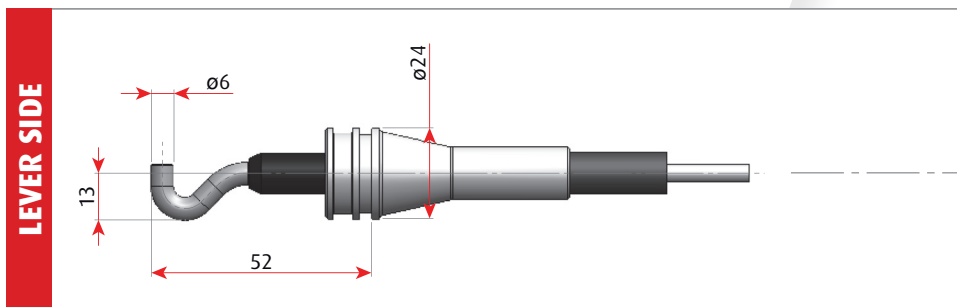

A	B	Thread (C)	Code
185	110	M14x1	0075922*mmmm
		M16x1.5	0075922-6*mmmm

HYDRAULIC DISTRIBUTOR SIDE

**Flexball Italiana S.r.l.**

Via San Luigi 13/A - 10043 Orbassano (To) - Italy

Tel 0039.011 90.38.900 - Fax 0039.011 90.38.747

info@flexballitaliana.com

www.flexballitaliana.com

**FLEXBALL**  
ITALIANA

WR CONTROLS GROUP

