

**Industrial
products**



**FLEXBALL
ITALIA ANNA**

WR CONTROLS GROUP

Production sites



WR Controls Flexball
Turin, Italy



WR Controls Europe
Timmele, Sweden



WR Controls Asia
Shanghai, China



WR Controls Europe
Tallinn, Estonia



Global Manufacturing Facilities

Since 2003 member of **WRControls Group**, with production facilities in Europe and Asia, **Flexball Italiana** is a global company with customers worldwide and leader in the design and manufacturing of remote control systems for the industrial sector and for several other fields.

Thanks to our technical competence with more than 50 years experience and one of the widest range of controls, we can provide customized solutions to maximize the performance of your vehicles.



FLEXBALL
ITALIANA
WR CONTROLS GROUP



Index

About us: business, development, engineering and production capabilities	p 4
CABLES	p 5
• Flexball cables	p 6
• Pull and push-pull cables	p 10
• Accessories	p 18
MECHANICAL CONTROLS	p 27
HYDRAULIC VALVE CONTROLS	p 29
• 1010	p 30
• 1500	p 32
• 1600	p 38
• 2000	p 40
• 2500	p 42
• 2800	p 48
• 2900	p 52
HEAVY DUTY CONTROLS	p 59
• E95	p 60
• 103	p 68
• 561	p 71
• 901	p 74
• 920	p 81
• 930	p 82
• 1068	p 83
• ETC	p 84
LIGHT DUTY CONTROLS	p 91
• 400	p 92
• 405	p 94
• 410	p 95
• 415	p 96
• 460	p 98
• 470	p 99
MECHANICAL PEDALS	p 101
• 1200	p 102
• 1220	p 104
• 1230	p 106

ELECTRONIC CONTROLS	p 107
• Joysticks 700	p 108
HAND THROTTLE CONTROLS	p 121
• 600	p 122
• 610	p 124
• 620	p 126
• 630	p 127
ELECTRONIC PEDALS	p 129
• 1240	p 130
• 1252	p 134
• 1260 and 1262	p 136
• 1270	p 138
• 1280	p 140
MECHATRONIC CONTROLS	p 143
HANDLES	p 147



ABOUT US: BUSINESS, DEVELOPMENT, ENGINEERING AND PRODUCTION CAPABILITIES

Located in Orbassano (Turin – ITALY), **Flexball Italiana** designs, engineers and manufactures “Flexball” ball bearing controls since 1960, wire cables since 1970 and control boxes for many different kind of applications for various industries in Italy, Europe and others countries in the world.

The main business areas are:

- railway, metro, tram and transport in general
- agricultural machinery
- construction equipment
- professional and pleasure boats
- truck and bus

We manufacture controls, either mechanical or electronic, for all those applications which require the transfer of a motion either linear or rotary.

All design and developments are carried out with Solidworks, 2D and 3D Mechanical CADs, in order to accomplish the following tasks:

- development of a product concept
- perform fully associative top-down and bottom-up design
- weight analysis
- animations to analyze how the product will work
- carry out of prototype design and industrialization

Flexball has the full capability to design, test and qualify all its equipments. Specific tests like endurance, friction, vibration, sand, dust or salt spray are carried on the products before their final release.

All the critical parts of our controls are produced internally. Three assembly lines and two manufacturing workshops permit a full quality control during all the production processes and a detailed information of each component produced. This kind of organisation is a mandatory condition to fulfil the On Time Delivery and Quality requirements requested by our customers.

1



Cables

FLEXBALL CABLES

The Flexball cable, recognizable from the green colour of the plastic cover, is an extremely flexible and sliding cable. It has a very reliable and robust construction which guarantees very high performances. If mounted properly, it will last “for ever”

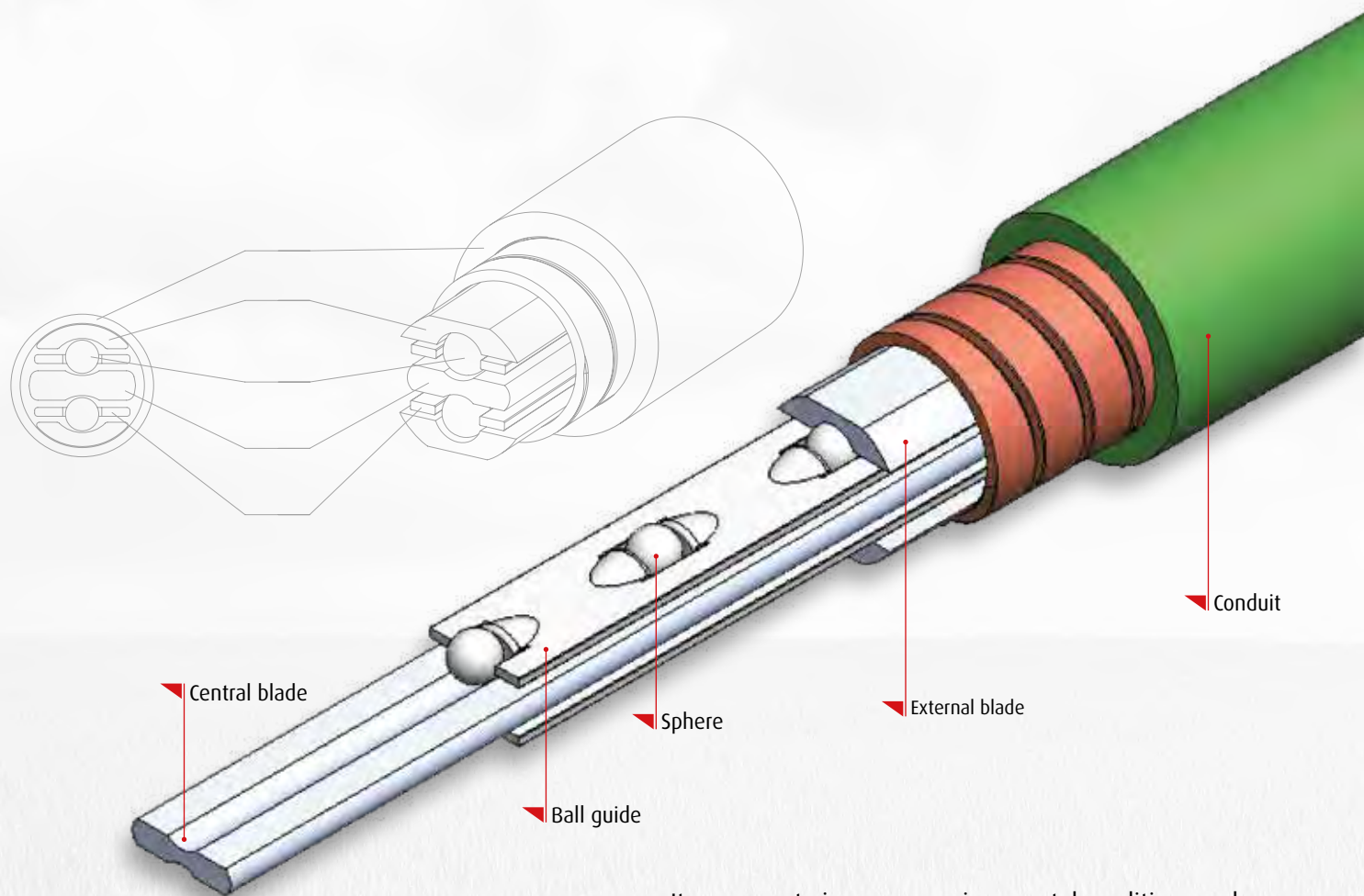

Its efficiency is highly better than any traditional push-pull cable. The Flexball cable maintains high mechanical efficiency and very low backlash which approaches to zero, even in complex routings and difficult installations. Flexball cable can be spatially laid on all the three dimensions with low bending radii and 97% efficiency, also under heavy loads.

It works reliably and without interruption, even at lengths over 60 meters. No maintenance or lubrication is necessary. It is indifferent to changes of temperature.

It can operate in severe environmental conditions such as moisture, condensation or icing, without impact on performance. For standard cables the working temperature is 108 °C but special cable versions can work up to 200 °C degrees.

It can transfer linear movements with a stroke up to 300 mm. The ball-bearing principle enables a smooth movement, low play and delay-free transfer of loads which can reach 15000 N in push and 25000 N in pull operation mode.

CONSTRUCTION

Ball bearing controls have an inner blade which is held between two rows of ball bearings by two outer blades, and all is contained in a high strength outer casing.

Stainless steel inner components guarantee an optimal lifetime with high fatigue resistance in any working condition.

Terminal and end fittings can be made of steel, stainless steel or brass.

APPLICATION

Ball bearing controls are generally used in applications with long routings and high tension and compression.

The **Flexball cable** is manufactured in lengths ready to install. It replaces complex solid rods, hydraulic, pneumatic or electric transfer devices.

HOW TO HANDLE AND STORE

The **Flexball cable** is delivered in a proper box and bent with an "8" shape to respect its minimum bending radius. Once received, it should be opened and stored as a straight line. If not possible, just leave it in the box like you have received it. Flexball cable must not be stored in circle, otherwise it can be seriously damaged.

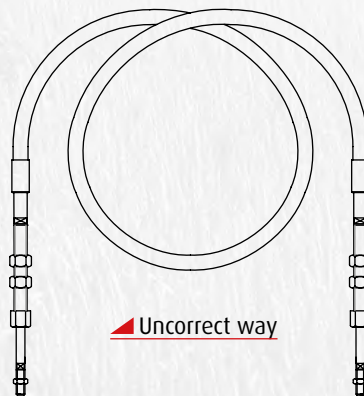
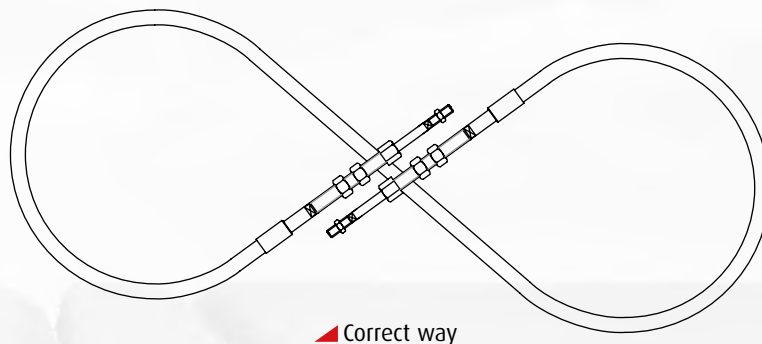

PRODUCT RANGE

The **Flexball cable** is available in different sizes, from type 55 which has a conduit diameter of 9.5 mm, to type 160 that has a conduit diameter of 24.3 mm.

The **Flexball cables** are available with several types of end fittings to fit the different application requirements.

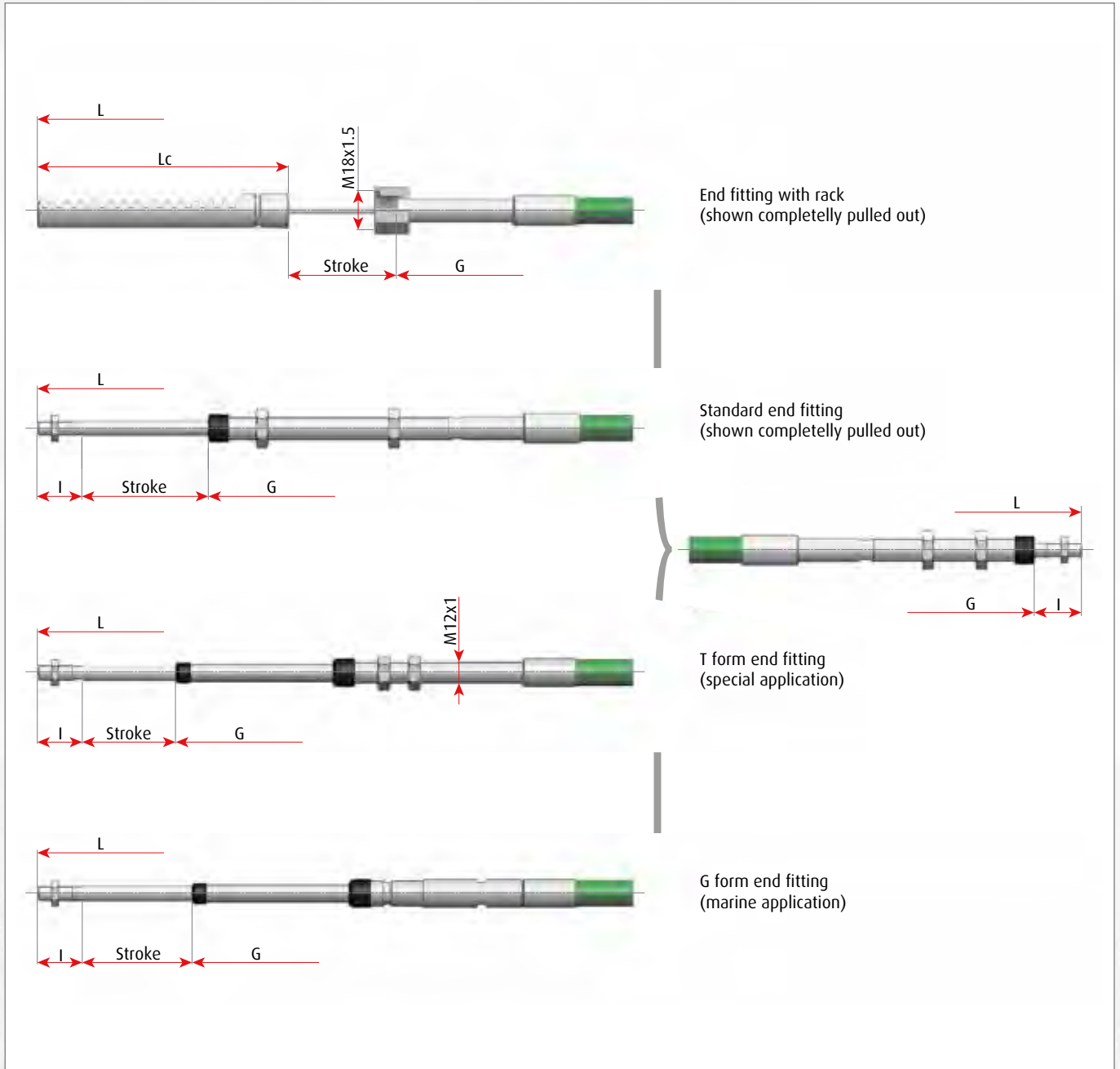

STANDARD FLEXBALL END FITTING DIMENSIONS

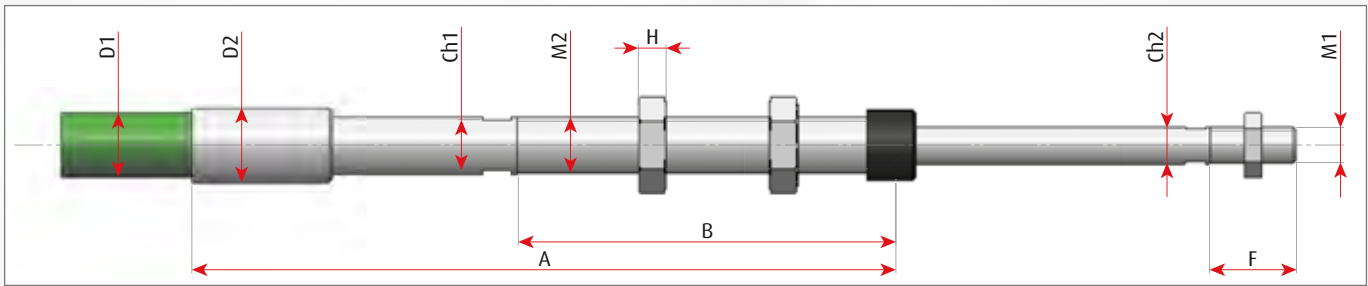

Cable type	Stroke	A	B	F	H	I	Ch1	Ch2	D1		D2		M1	M2	LC	Rack module (mm)	Push load (N)	Pull load (N)	Bending radius (mm)	Weight per meter (gr)	E _c
									AN*	ACP*	AN	ACP									
55	50	130	55	20	5	26	8	5	9.5	12	12	14	M6x1(M5x0.8)	M10x1	126	1.5	300	800	100	245	0.3
	70	145	70																		
	100	175	100																		
70	50	142	55	30	8	37	11	6	11	12.8	13	15	M7x1(M6x1)	M12x1	126	1.5	1550	2800	120	320	0.18
	70	157	70																		
	100	187	100																		
	150	237	150																		
	200	292	170																		
95	50	163	70	30	8	37	14	9	14.3	16.5	16	19	M10x1.5	M16x1.5	126	1.5	2700	5000	140	518	0.15
	70	183	90																		
	100	213	120																		
	150	263	170																		
	200	313	220																		
125	50	195	70	35	9	45	17	11	17	21	20	24	M12x1.5	M18x1.5	-	1.5	5300	10000	200	827	0.05
	70	215	90																		
	100	245	120																		
	150	295	170																		
	200	345	210																		
160	50	240	100	35	10	45	21	13	24.3	28	-	-	M14x1.5	M22x1.5	-	-	6500	15000	250	1280	0.03
	70	260	120																		
	100	290	150																		
	150	340	200																		
	200	390	250																		
	250	440	300																		
	300	490	350																		

Notes:

- AN: standard cable coating
- ACP: reinforced cable coating
- Cable's elongation (mm): Cable's length (m) x Applied Load (N) x E_c x 0.01

Pull and push-pull cables

PULL CABLES

Flexball has a wide range of wire cables that is the result of the experience of 50 years of design of pull and push-pull cables for the most different applications: from the simple pull throttle cable to the more sophisticated gear shifter cable or to the very performing cable of a power transmission pump.

Wire rope controls are only used in tension applications and can be matched with a variety of handles and levers on one side and several attachments (blades, clevis, threaded terminal) on the other side.

The pull cable is schematically composed of conduit, wire and end fittings. The mixing of these three basic elements determines a big choice of cables.



CONDUIT FOR PULL CABLES

Type of conduit	Pull load (N)	Bending radius (mm)	Conduit external diameter (mm)	Conduit internal diameter (mm)	Conduit colour	In liner tube
012	800	100	7	2.3	Black	POM
015	1000	80	6.9	2.3		Teflon
020	1200	80	6	2.3		POM
030	3500	120	10	4.3		POM
040	6000	140	13.4	7.4		POM

WIRE FOR PULL CABLES

Wire diameter (mm)	Pull load (N)	Structure	Material
2	800	7 wires	Stainless steel AISI316
	1000	19 wires	
	1200	49 wires	
	1400	133 wires	
2.5	1800	19 wires	
3	2500	19 wires	
4	3500	49 wires	
6	6000	133 wires	
6HD	20000	133 wires	R2060

PUSH-PULL CABLES

Push-pull control cables provide an efficient, highly reliable and lightweight solution of remote actuation at long distances. Push-pull cable main feature is the high flexibility and its capability to adapt to the different applications. Push-pull cables can be used in the agriculture, industrial, automotive, marine and railway sectors.

Basically the push-pull cable is made of a conduit, a wire which slides inside the conduit and two terminals, one on each side of the cable. The end fittings are the linkage between the cable and other mechanical devices.

The construction materials are plastic or metal and are chosen depending on the application and environmental conditions. Metals are usually steel, stainless steel or brass.

In addition to the cables reported in this catalogue, it is available a wide variety of special cables; our technicians are at your disposal to guide you in the selection of the right cable for your application.

Cables are basically classified according to these following main features:

- length
- force to be transmitted
- stroke
- type of end fitting

Furthermore, it must be taken into account any feature related to the specific working conditions, such as temperature, environment, flexibility, efficiency, lifetime, duty cycle, etc. In the following pages are described the different types of cables classified on the base of the features just described here above.

Type of cable	Push load (N)	Pull load (N)	Bending radius (mm)	External conduit diameter (mm)	Wire diameter (mm)		Conduit colour
E2	300	800	100	7	1.9		Black
E3	400	1000	120	8.5			
V4	500	1200	120	8	3.65		Yellow
V5	700	1500	140	10	4.7	5	
V6	900	2000	160	11.5	5.7		
V7	1200	2500	180	12.1	6		
V8	1400	2000	200	14	7.6		
01	300	800	80	7	2.7		Black
07	800	2000	150	9.5	3.7		
07E	800	1800	150	9.5	3.6		
010	1000	2000	140	9.2	3.2		
017	1000	2000	160	9	3.2		
018	2000	4500	200	14.5	6.4		

BENDING RADIUS

The table in the previous page reports the recommended minimum bending radius for each type of cable. Higher is the bending radius, better is the performance of the cable and longer is its lifetime.

CALCULATION OF THE STROKE

In case of linear actuation, to understand the necessary stroke it is enough to measure the difference between the initial position of the actuation point and the end position after the cable has been full operated.

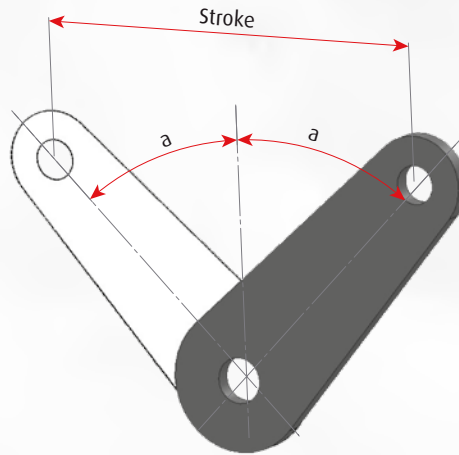

If the cable is connected to the lever, the connection point moves on an arc profile but the travel is its segment. Cable fitting with G and T shapes are indicated to operate in these conditions because the rods are running into a swiveling sleeve that can compensate the deflection. Also cable fitting with F shape can operate in this condition, but it is necessary to use a bulkhead swivel to compensate the deflection.

To guarantee the longest operating life and the best efficiency of the cable, the deflection has to be reduced as much as possible. One of the factors that contributes to the deflection's reduction is how the cable is mounted: the cable has to be mounted as per the side picture.

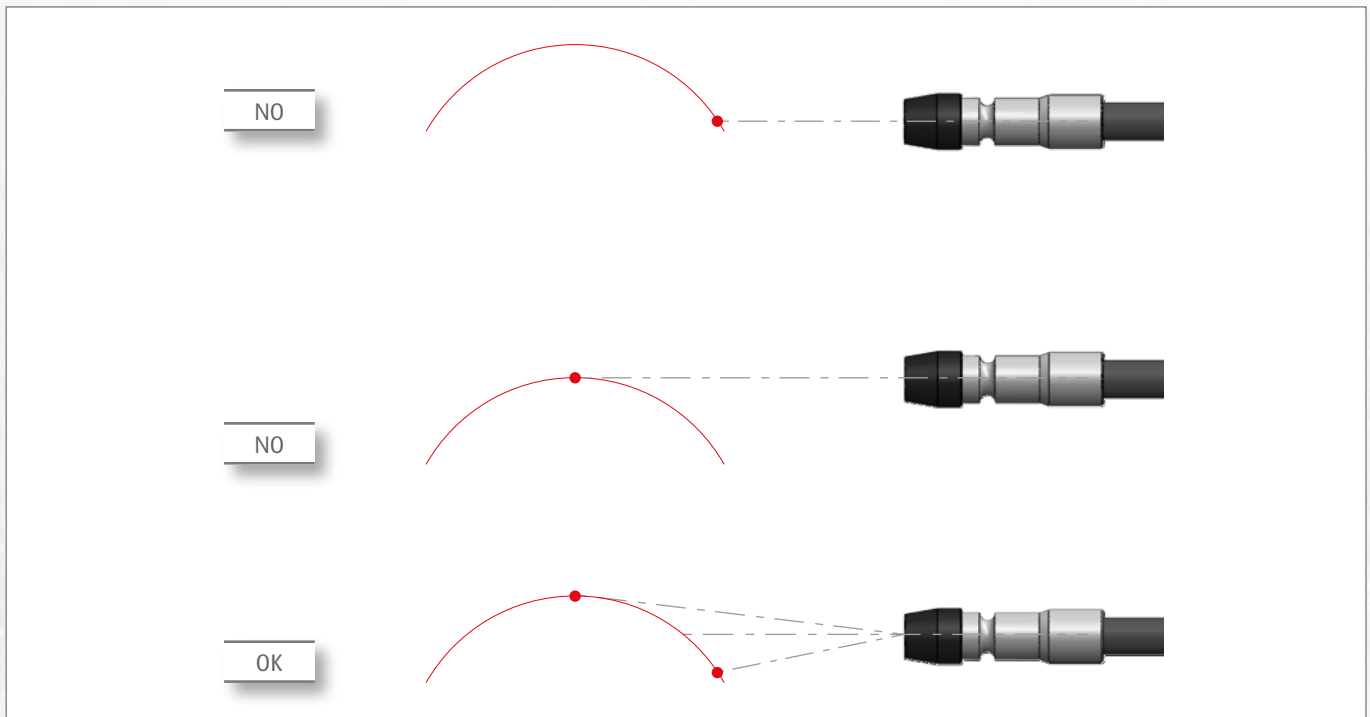

BACKLASH

The backlash is caused by the free play between the core (wire) and the conduit. It is measured as the lost motion (on the output) under light input forces applied on the cable. Backlash increases proportionally with the bending degrees and it becomes evident during cable's changes of direction.

The backlash is related to diameter differences between core and conduit, the input force and the total number of bending degrees of the cable once installed. Here below, we summarize the backlash of each type of cables, calculated considering a total bending of 360° degrees.

TYPE OF CABLES	BACKLASH
E2/E3	3 mm
V4	3 mm
V5	3.2 mm
V6	3.5 mm
V7	3 mm
V8	3.5 mm
01	1.3 mm
07	1.2 mm
07E	1.9 mm
010	1.3 mm
017	1.3 mm
018	2.6 mm

EFFICIENCY

Efficiency is the relation between the input force necessary to move the load applied on the other end of the cable and the output load. The relations between input force and output load are the following:

- input force = output load x bending factor
- output load = input force / bending factor

The bending factor is related to the total bending degrees of the cable installation, as shown in the following table:

Total degrees of bending in cable installation	90°	180°	270°	360°
Bending factor	1.2	1.4	1.6	1.8

WORKING TEMPERATURE

Flexball push-pull cables can operate from -20°C to +70°C with standard lubricant. In case push-pull cables are lubricated with special grease, the operating temperature field is from -40°C to 110°C. To operate at temperatures beyond standard specification, please contact Flexball technical department as a high temperature conduit proof is available.

END FITTINGS FOR PUSH-PULL CABLES

Several kind of end fittings are available as reported here below.

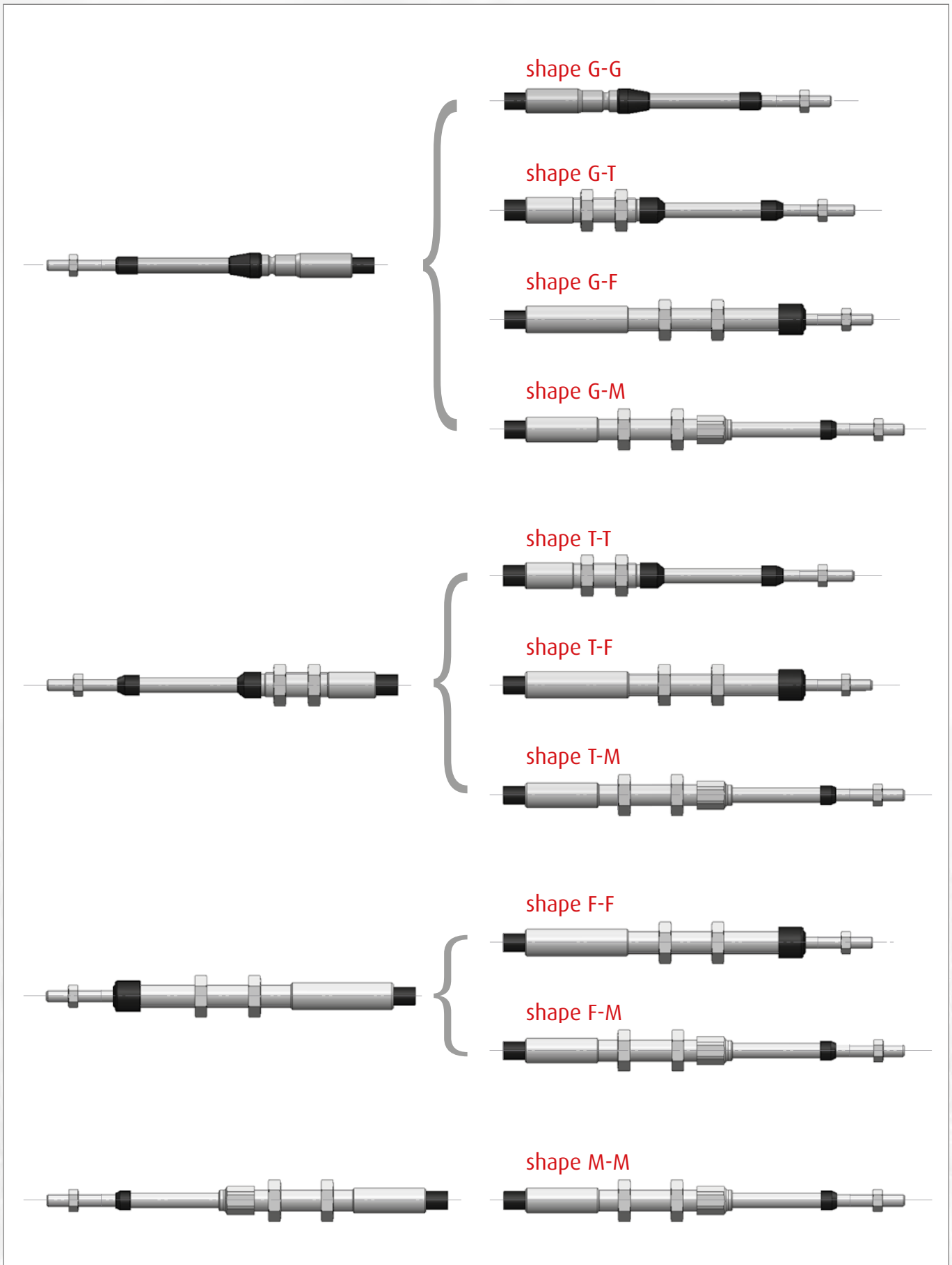

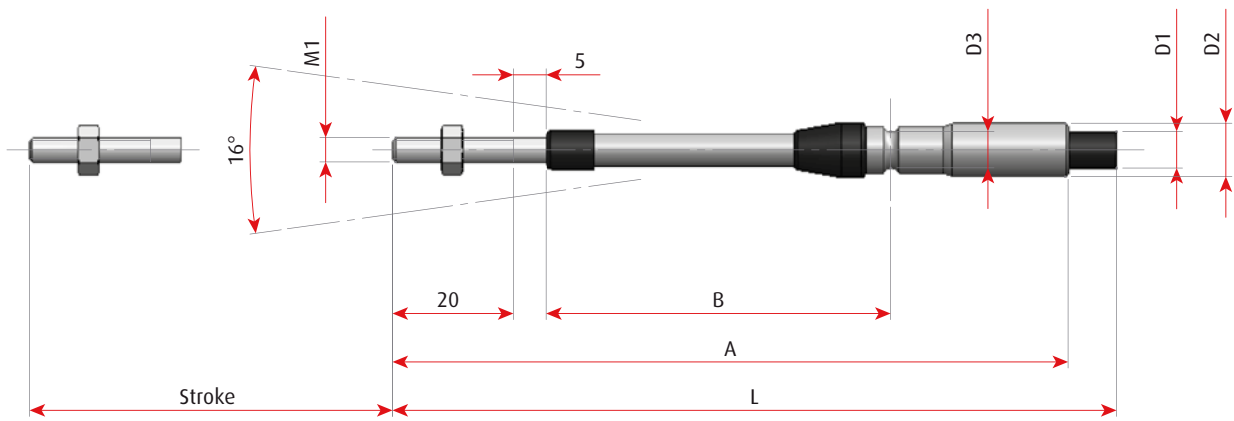

CABLE FITTING G SHAPE

Type	Stroke	A	B	M1
E2 E3 01	50	151	84	M5x0.8 10/32
	75	176	109	
	100	201	134	
V4	125	229	162	M5x0.8
	50	151	80	
	75	176	105	
V4	100	201	130	M5x0.8
	125	226	155	
	50	163	83	
75	188	108		
100	213	133		
V5 07 07E V6 010	125	238	158	M6x1
	150	263	183	
	200	313	223	
V7 V8	50	167	95	M8x1.25
	75	192	120	
	100	217	145	
	125	242	170	
	150	267	195	
200	317	245		

CABLE FITTING T SHAPE

Type	Stroke	A	B	R	H	M1	M2
E3	50	120	80	30	5	M5x0.8 (10/32 UNF)	M11x1 (M12x1.75)
	75	155	105				
	100	180	130				
V4	125	208	158	30	5	M5x0.8	M11x1
	50	143	88				
	75	168	113				
V4	100	193	138	30	5	M5x0.8	M11x1
	125	218	163				
	50	160	85				
75	185	110					
100	205	135					
V5 07 07E V6 010 017	125	235	160	37	8	M6x1	M14x1 (M16x1.5)
	150	260	185				
	200	305	237				
V7 V8	50	196	91	47	8	M8x1.25	M16x1.5
	75	221	116				
	100	246	141				
	125	271	166				
	150	296	191				
	200	247	247				

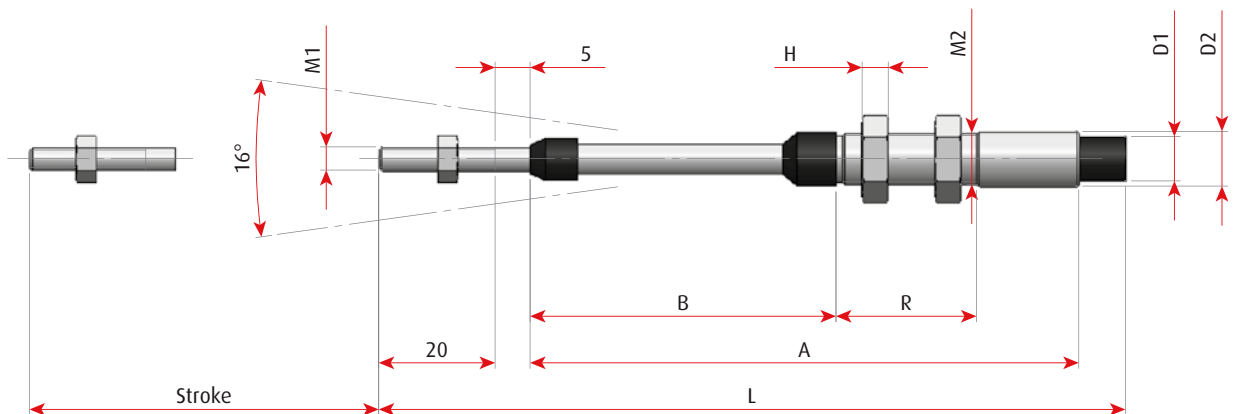

Type	Stroke	A	B	R	H	M1	M2
V4	50	112	65	52	5	M5x0.8 (M6x1)	M10x1
	75	137	90	77			
	100	162	115	102			
V5 07 07E V6 010 017	50	134	79	68	8	M6x1 (M7x1)	M12x1
	75	159	104	93			
	100	184	129	118			
	125	209	154	143			
	150	234	179	168			
V7 V8	50	132	76	59	8	M8x1.25 (M10x1.5)	M16x1.5
	75	157	101	84			
	100	182	126	109			
	125	207	151	134			
	150	232	159	159			

CABLE FITTING F SHAPE

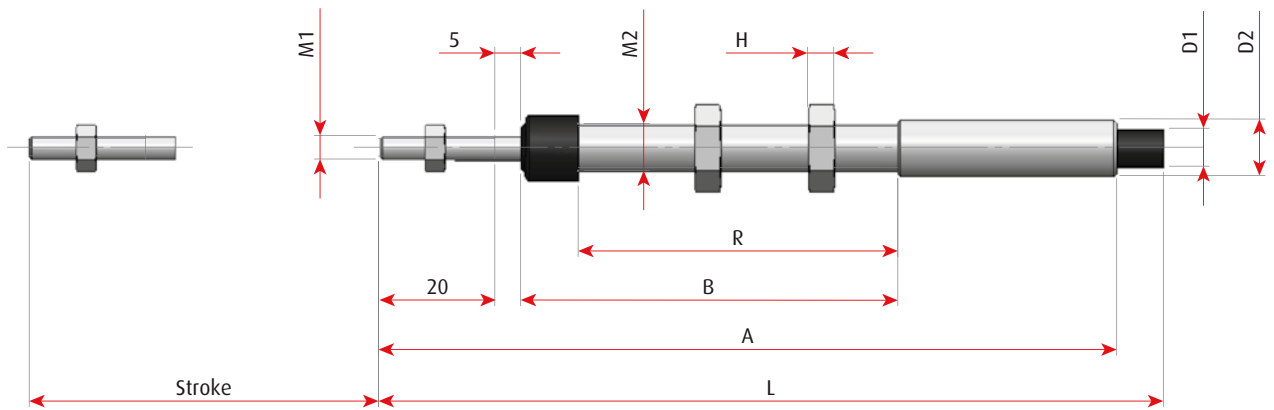

CABLE FITTING M SHAPE

Type	Stroke	A	B	R	H	M1	M2
V4	75	192	118	36	8	M6x1	M12x1
V5 07 07E V6	50	166	94	38	8	M6x1	M12x1
	75	191	119				
	100	216	144				
	125	241	169				
	150	266	194				

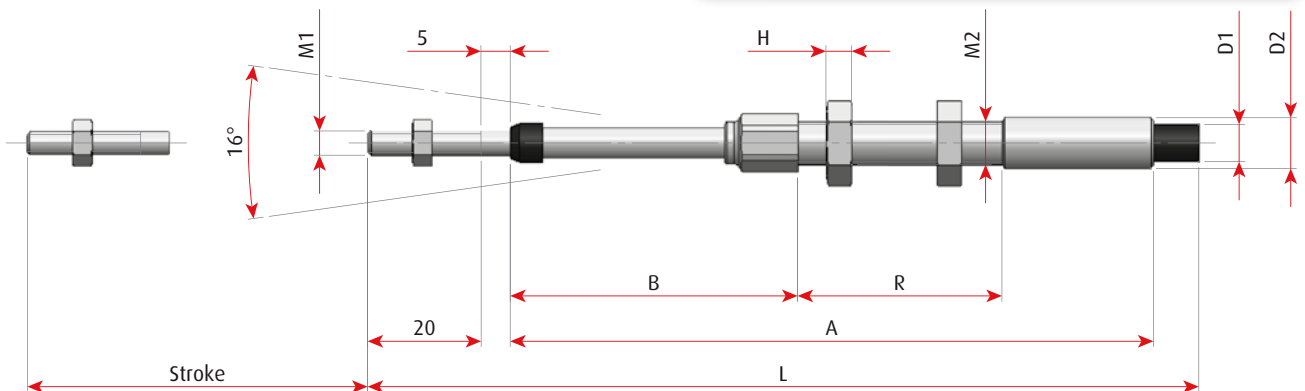

CODES

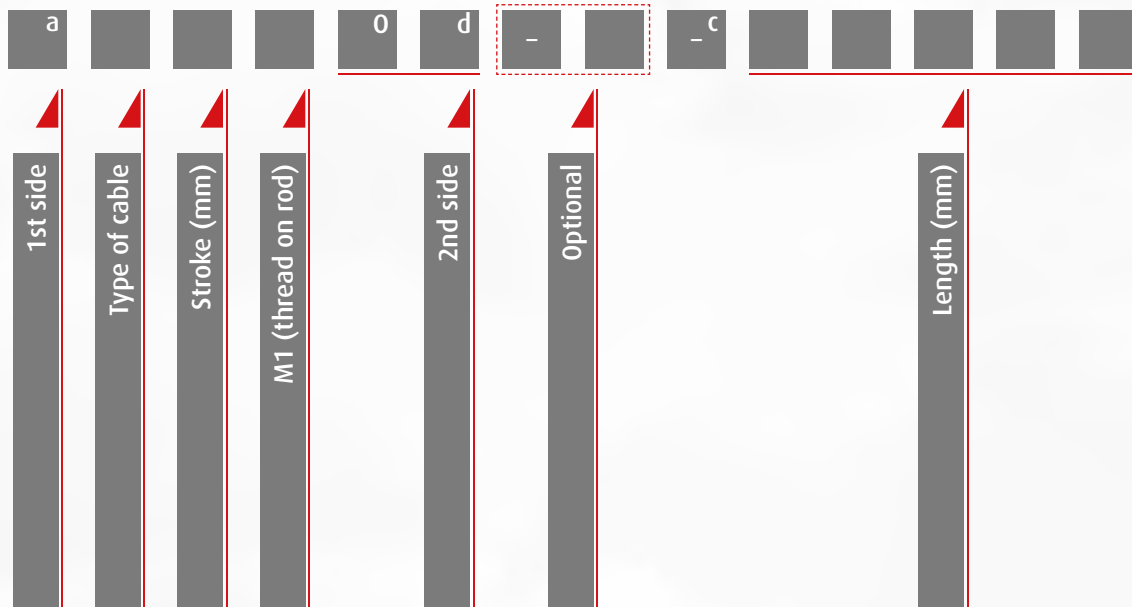

Cable shape	Reference
G	1
T	2
F	3
M	4

Type of cable	Reference
010/017	0
E2	2
E3	3
07/07E	7
V4	4
V5	5
V6	6
V7	12
V8	8

Stroke	Reference
30/35	1
50	2
75	3
100	4
125	5
150	6
200	8

Thread on rod	Reference
10/32 UNF	1
M12x1.5	2
1/4 UNF	3
M5x0.8	5
M6x1	6
M7x1	7
M8x1.25	8

Notes:

- If the cable has different shapes on the two ends:
 - the one which has the lower reference takes the first position (a)
 - the other end takes position (b)
- Position c: if the cable is type 07E (economical), please replace the "-" with "E"

ACCESSORIES

Flexball offers a complete range of accessories that can be mounted either on Flexball cables or on push-pull cables

ACCESSORIES FOR RODS

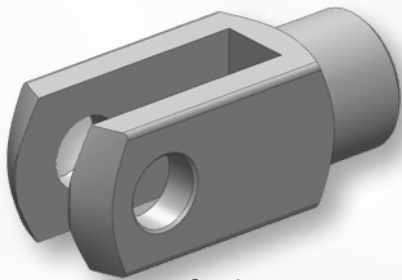

Clevis

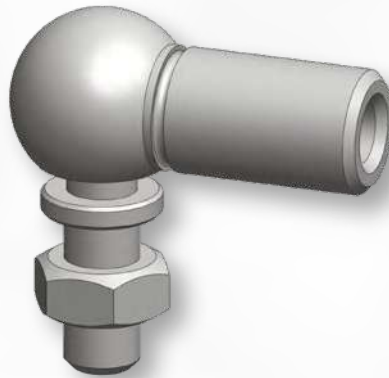

Ball joint

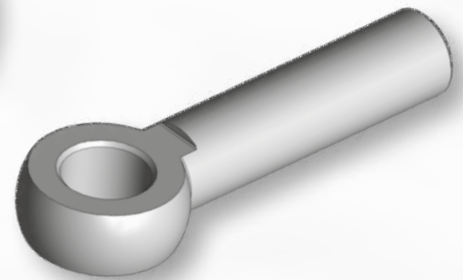

Eyebolt

ACCESSORIES FOR HUBS

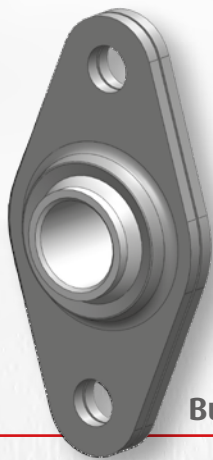

Bulkhead swivel



Bellow

HANDLES



T plastic handle



T aluminum handle

To determine the right size of the fork, look at the dimension "M1" on the drawings and tables of Flexball, pull and push-pull cables.

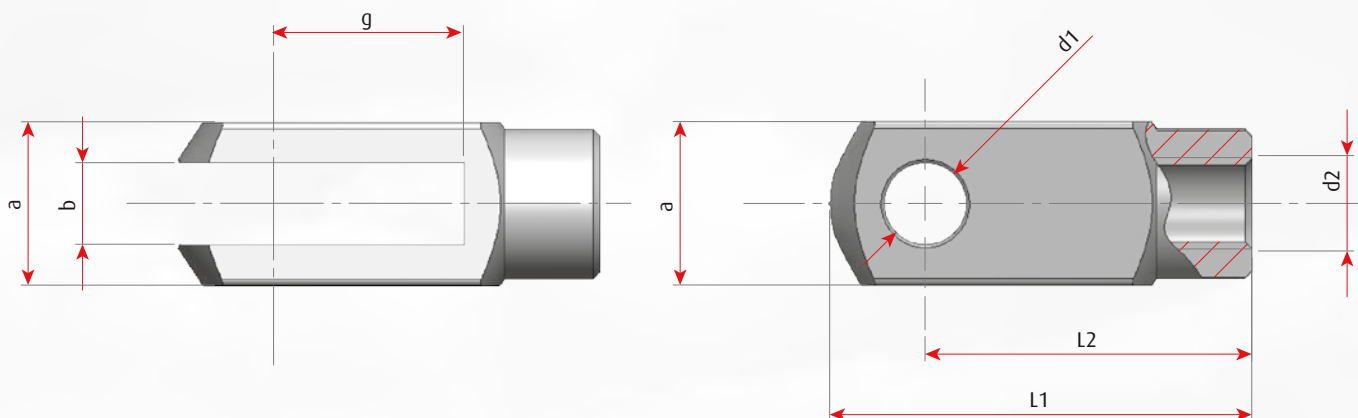
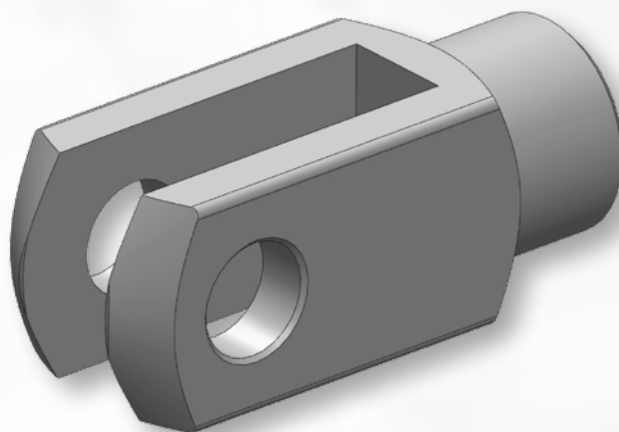

Type	b	d1	d2	g	a	L1	L2	Material	Code
5X10	5	5	M5	10	10	26	20	Zinc plated steel	0-0099.01.00.01
			M6						0-0099.01.00.02
5X20	5	5	M5	20	10	36	30	Zinc plated steel	0-0099.01.00.03
			M6						0-0099.01.00.04
6X12	6	6	M6	12	12	31	24	Zinc plated steel	0-0099.01.00.06
			M7						0-0099.01.00.07
6X24	6	6	M5	24	12	43	36	Zinc plated steel	0-0099.01.00.08
			M6						0-0099.01.00.10
			M7						0-0099.01.00.12
8X16	8	8	M6	16	16	42	32	Zinc plated steel	0-0099.01.00.15
			M7						0-0099.01.00.16
8X32	8	8	M6	32	16	58	48	Zinc plated steel	0-0099.01.00.17
			M7						0-0099.01.00.19
			M8						0-0099.01.00.21
10X20	10	10	M10	20	20	52	40	Zinc plated steel	0-0099.01.00.22
10X40	10	10	M8	40	20	72	60	Zinc plated steel	0-0099.01.00.25
			M10						0-0099.01.00.26

Note:

All the accessories with rod's thread M5 can also be mounted on cables with rod's thread 10/32 UNF.

BALL JOINT

To determine the right size of the ball joint, look at the dimension "M1" on the drawings and tables of Flexball, pull and push-pull cables.

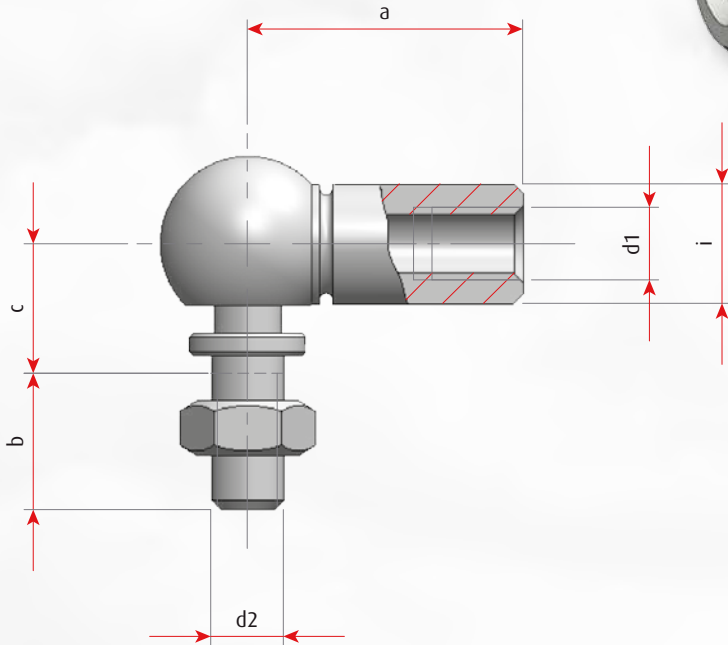
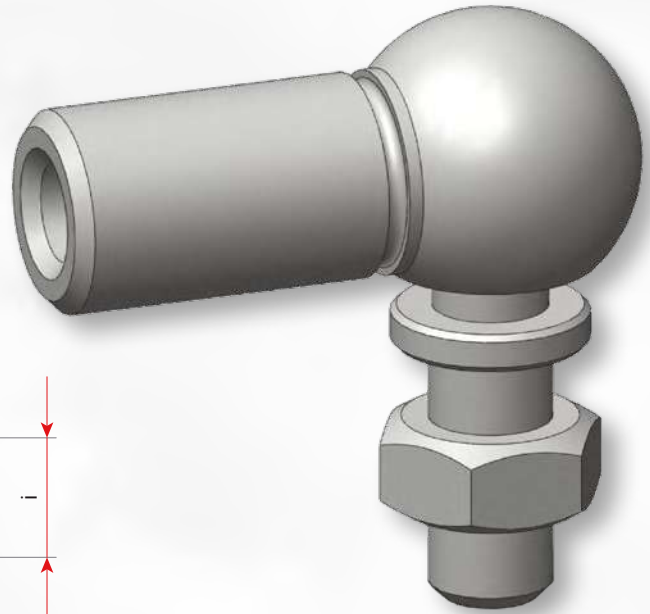

Type	a	i	d1	d2	c	b	Material	Code
AS8	22	10	M5	M5	9	7	Zinc plated steel	D-0099.04.01.00
AS10	25	12	M6	M6	11	8	Zinc plated steel	D-0099.04.03.00
AS13	30	14	M6	M8	13	12	Zinc plated steel	D-0099.04.07.02
	30	14	M7	M7	13	12		D-0099.04.06.00
	30	14	M7	M8	13	12		D-0099.04.07.01
	30	14	M8	M8	13	12		D-0099.04.07.00
AS16	35	16	M10	M10	16	14	Zinc plated steel	D-0099.04.09.00

EYEBOLT

To determine the right size of the eyebolt, look at the dimension "M1" on the drawings and tables of Flexball, pull and push-pull cables.

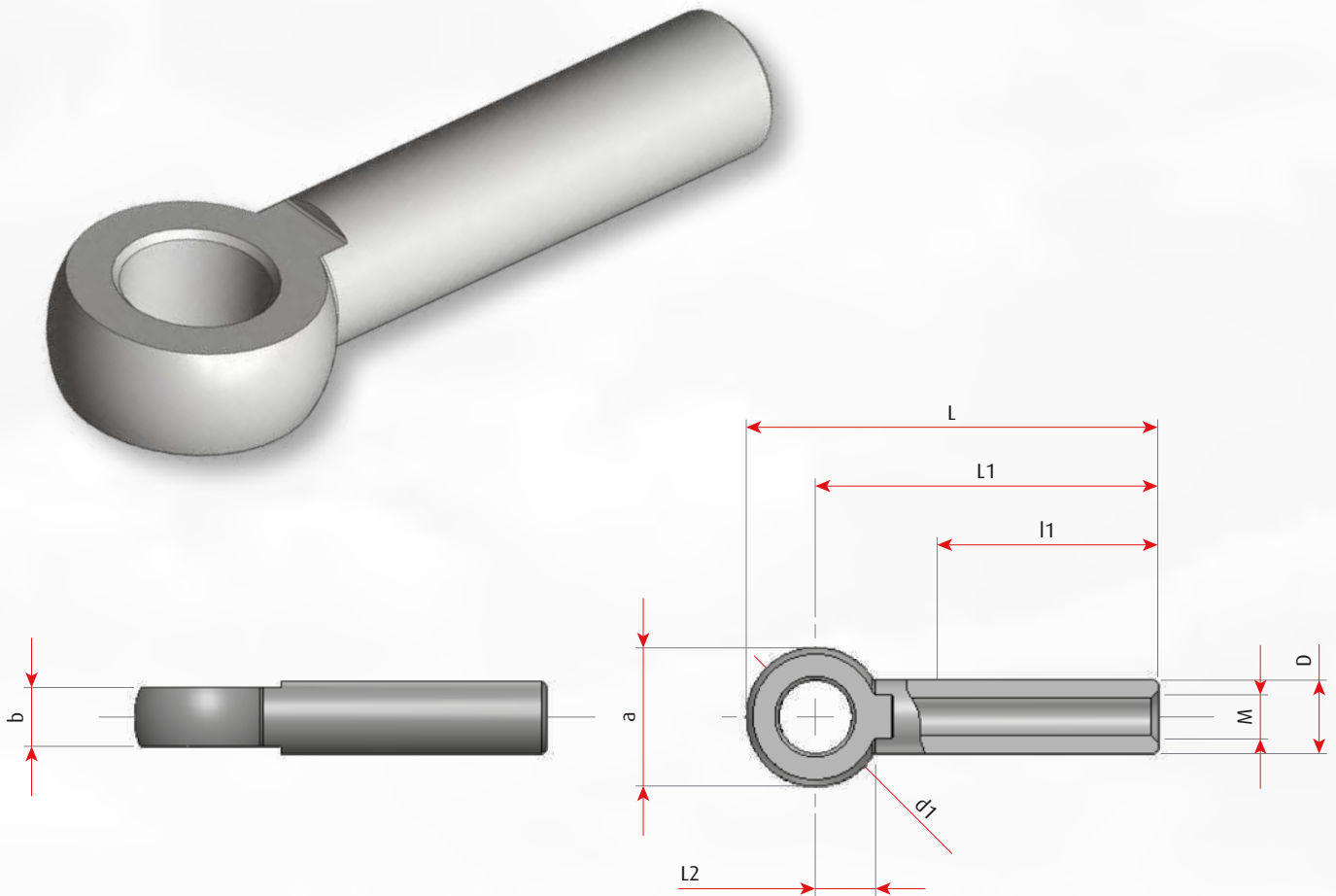

a	b	d1	L	L1	L2	D	M	l1	Material	Code
19	8	8	56	46	9	10	M5x0.8	30	Zinc plated steel	D-0099.06.02.00
							M6x1			D-0099.06.03.00
							M7x1			D-0099.06.04.00
							M8x1.25			D-0099.06.04.02
19	8	10	56	46	9	10	M6x1	30	Zinc plated steel	D-0099.06.03.01
12	6	6	46	40	8	10	M6x1	20	Zinc plated steel	D-0099.06.06.00
							M7x1			D-0099.06.07.00
19	8	10	56	46	9	10	M6x1	30	Zinc plated steel	D-0099.06.04.03
							M7x1			D-0099.06.04.01
							M8x1.25			D-0099.06.04.04
24	12	12	72	60	19	18	M12x1.5	30	Zinc plated steel	D-0099.06.08.00
20	10	10	65	55	16	16	M10x1.5	30	Zinc plated steel	D-0099.06.09.00
30	15	16	70	55	22	24	M12x1.5	30	Zinc plated steel	D-0099.08.02.00

BULKHEAD SWIVEL

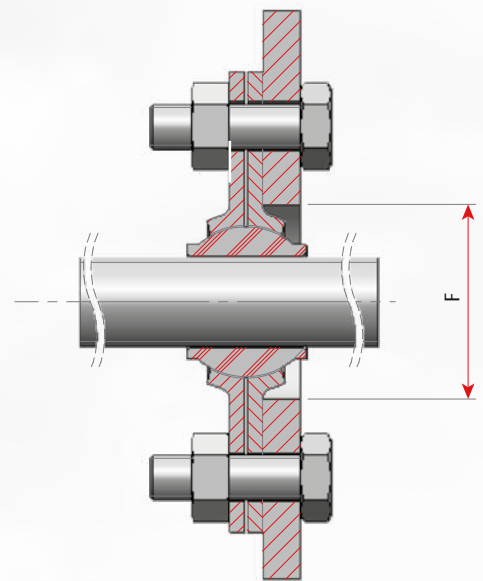
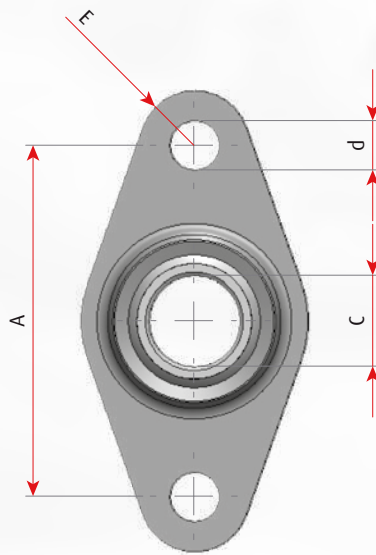
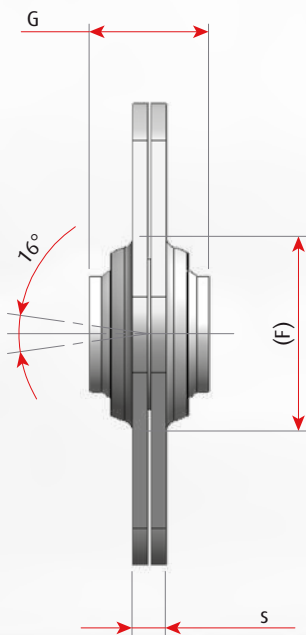
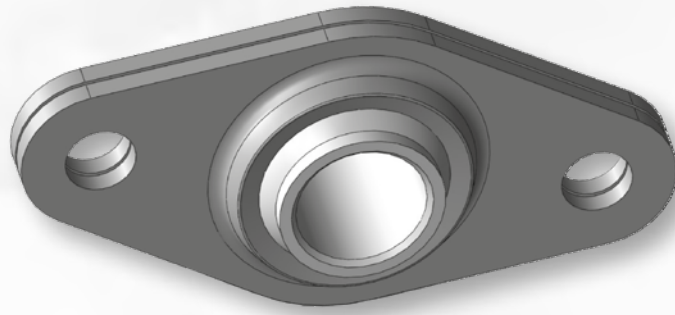

Note:

"F" is the dimension of the hole that has to be drilled on the bracket where the bulkhead swivel will be fixed. The above picture shows the correct mounting of the bulkhead against the bracket.

Type	Application	A	b	C	F	G	s	Ch	Material	Code
55	Flexball 55	30	5.2	10.2	20	12	3	14	Zinc plated steel	0-0099.03.00.01
	V4 F-F shape									
70	Flexball 70	40	6.2	12.2	25	16	4	17	Zinc plated steel	0-0099.03.00.04
	V5 F-F shape									
	07 F-F shape									
	V6 F-F shape									
	017 F-F shape									
95	Flexball 95	52	8.2	16.2	34	22	5	25	Zinc plated steel	0-0099.03.00.07
	V8 F-F shape									
125	Flexball 125	56	8.2	18.2	36	25	5	27	Zinc plated steel	0-0099.03.00.09
125 Vofa	Flexball 125	56	8.2	18.2	36	25	14	27	Brass	0-0099.03.00.12
160	Flexball 160	60	10.2	22.2	40	27	16	32	Brass	0-0099.03.00.14

BELLOW

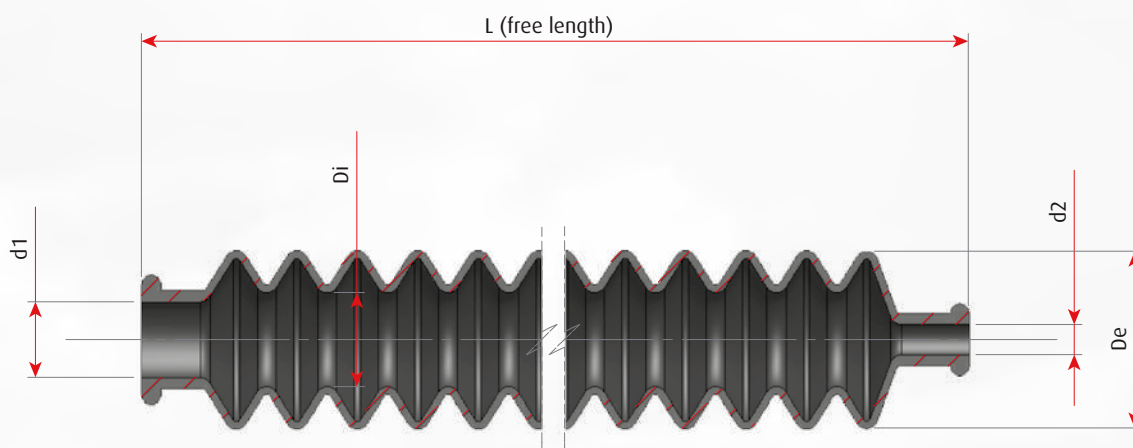
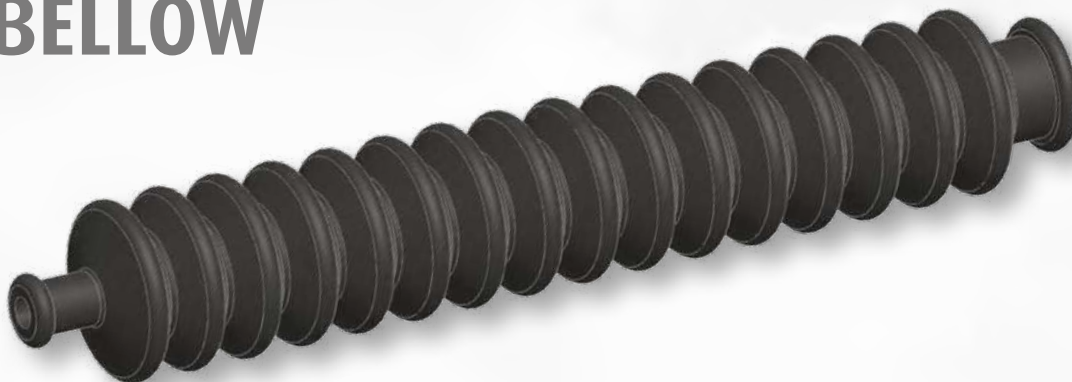

De	Di	d1	d2	L	Number of rings	Material	Collar size	Max stroke	Code
40	21	6	20	108	6	EPDM 20/50	M10x1 M12x1 M16x1.5 M18x1.5 M22x1.5	75	D-0099.05.02.00
40	21	6	20	108	6	MTA80-55I flame resistant			D-0099.05.02.02
40	21	6	20	140	8	EPDM 20/50		100	D-0099.05.03.00
40	22	12	33	152	8	EPDM 20/50	M18x1.5 M22x1.5	100	D-0099.05.03.01
40	22	12	33	152	8	MTA80-55I flame resistant			D-0099.05.06.00
40	21	6	20	140	8	MTA80-55I flame resistant			D-0099.05.08.00
40	22	12	33	215	12	MTA150-50I flame resistant		150	D-0099.05.07.00
45	21	8	25	164	7	PVC	M18x1.5	100	D-0099.05.11.00
22	10	4	7	90	8	EPDM 50/45	A plastic stripe should be used where required	100	D-4413995
25	12	7	10	147	16	EPDM 50/50		100	D-0099.05.10.00
21	12	7.5	6.9	95	17	EPDM 50/50		75	D-0099.05.01.00

T HANDLE PLASTIC



Thread	Handle colour	Code
M5	Red	D-0099.17.01.00
M6		D-0099.17.01.01

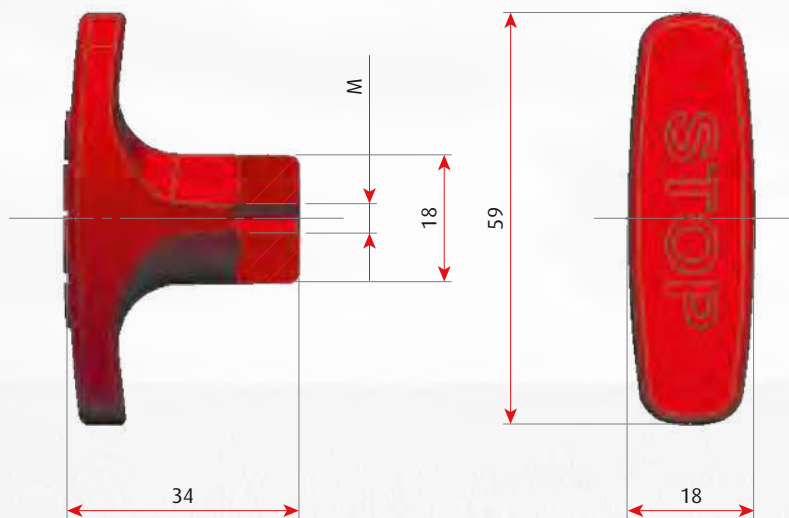

T HANDLE ALUMINIUM

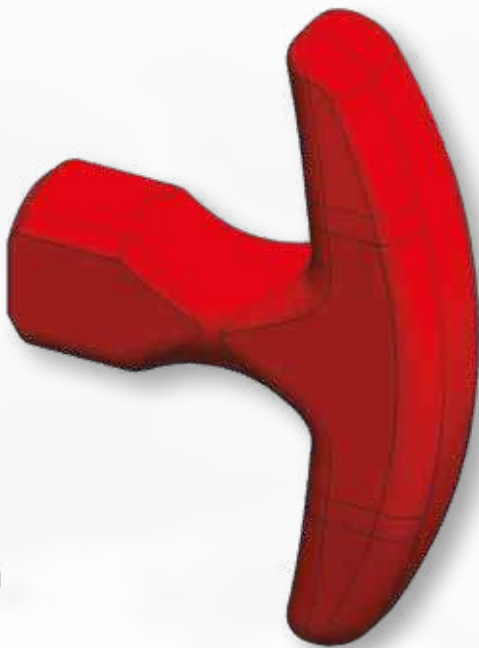

Thread	Handle colour	Code
M5	Black	D-0320.03.30.00
	Red	D-0320.03.35.00
M6	Black	D-0320.03.20.00
	Red	D-0320.03.15.00
M7	Black	D-0320.03.45.00
M8	Black	D-0320.03.10.00
	Red	D-0320.03.25.00
	Yellow	D-0320.03.10.01

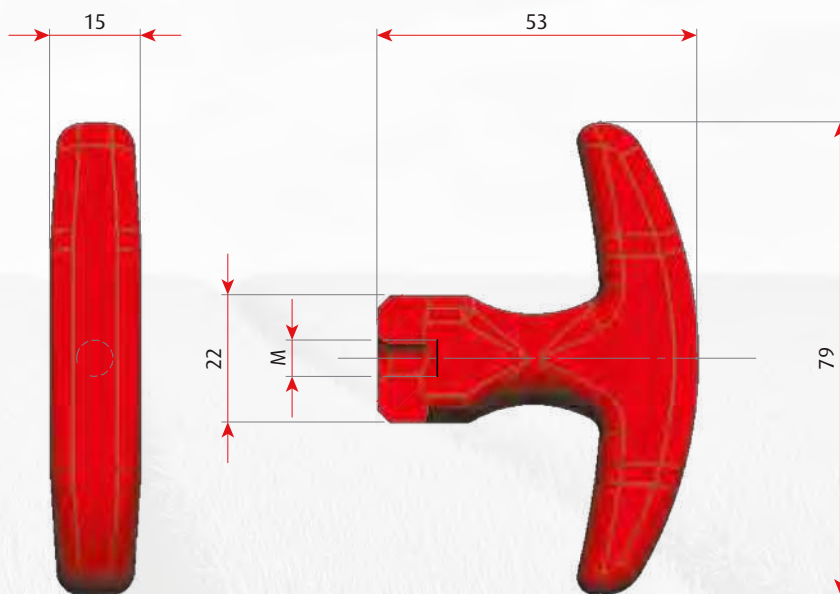



2



Mechanical Controls



Controls for hydraulic valves

CONTROLLERS

Single axle controller

- cable exits at 180 degrees with respect to the lever: series 1000
- cable exits at 90 degrees with respect to the lever: series 1500
- cable exits at 45 degrees with respect to the lever: series 1600

Double axle controller

- heavy duty joystick for construction equipment and agricultural applications: series 2000
- heavy duty joystick for construction equipment and agricultural applications: series 2500
- light duty joystick for agricultural applications: series 2800

At the end of this chapter are described the connection kits for the majority of the hydraulic distributors.

▲ SINGLE AXIS



1010



1500



1600

▲ JOYSTICK



2000



2500



2800



2900

1010

Single axis

It is made with an aluminium alloy body

Push-pull cable exits at 180 degrees with respect to the lever. It is used for the command of gears, cranes, stabilizers and hydraulic distributors in general.

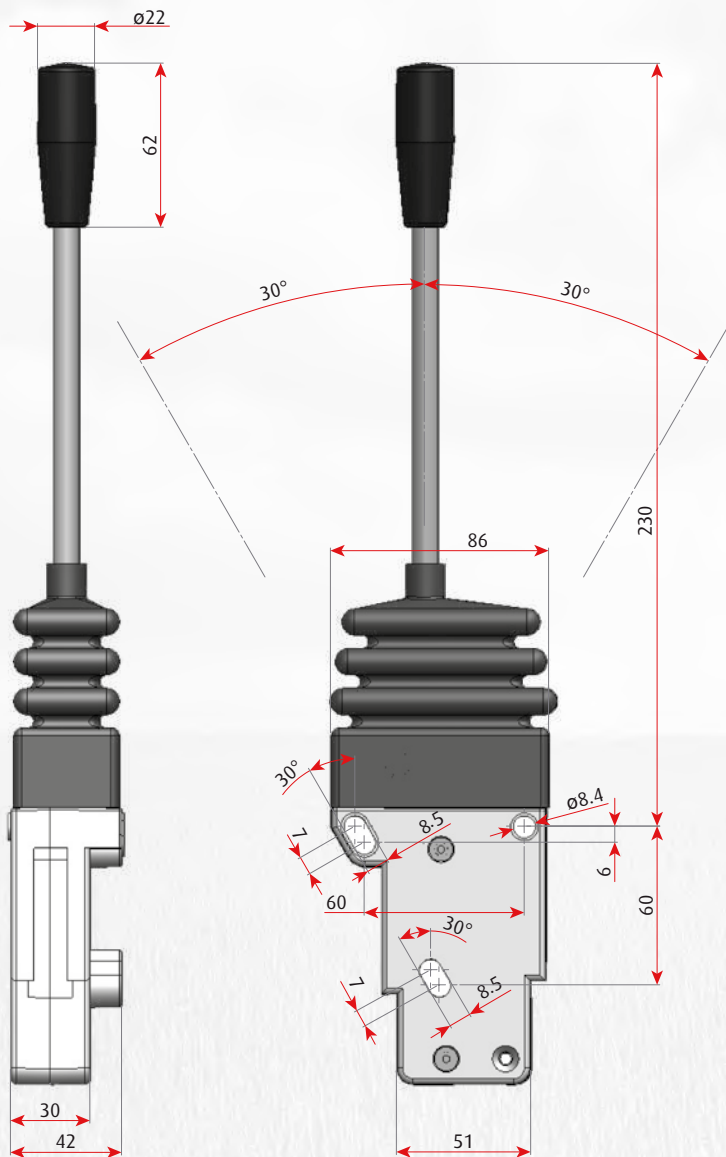

SPECIFICATION

- Possibility to mount side by side for multi axes applications
- Cable stroke: +/- 18 mm
- 300 N maximum working load

CODES

Version	Code
Self centring lever	1010

PUSH-PULL CABLES WHICH FIT WITH LEVER 1000

LEVER SIDE

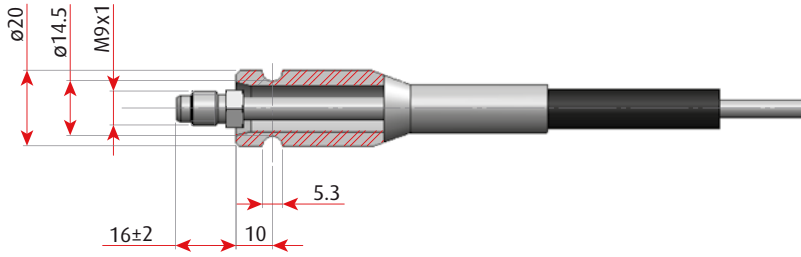

- The end fittings are represented with the cable at mid stroke position

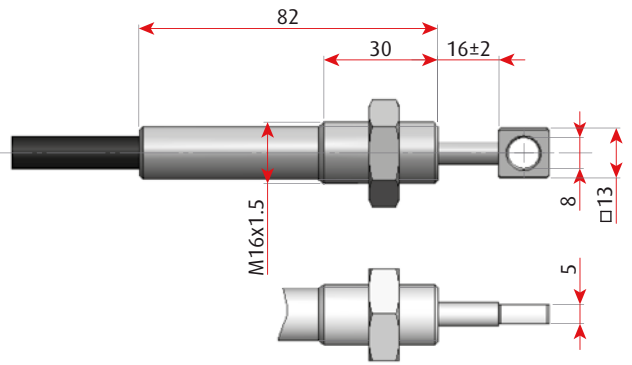

◀ Cable type 07E, code 0075841*mmmm

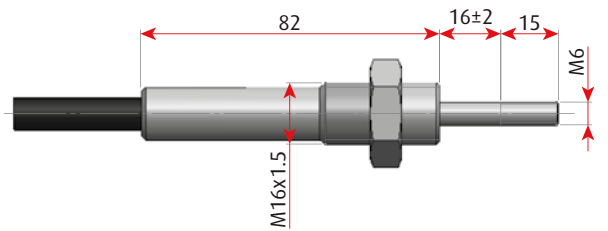

◀ Cable type 07E, code 0075841*mmmm

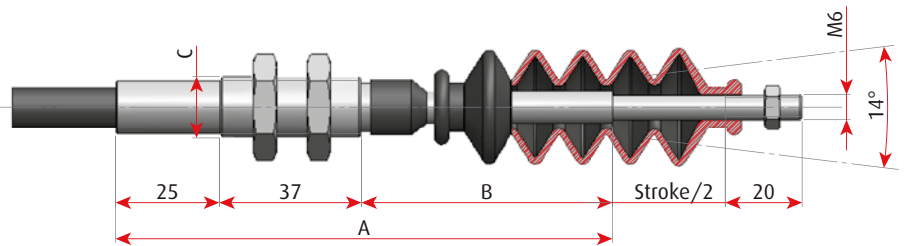

A	B	Thread	Code
125	38	M14x1	0075844*mmmm
		M16x1.5	0075844-6*mmmm
160	45	M14x1	0075840*mmmm
		M16x1.5	0075840-6*mmmm

HYDRAULIC DISTRIBUTOR SIDE

Mechanical Controls

2

1500

Single axis

▼ Its body is made of aluminium

Push-pull cable exits at 90 degrees with respect to the lever. It is used for the command of gears, stabilizers, lawn mowers, cutting machines and hydraulic distributors in general.

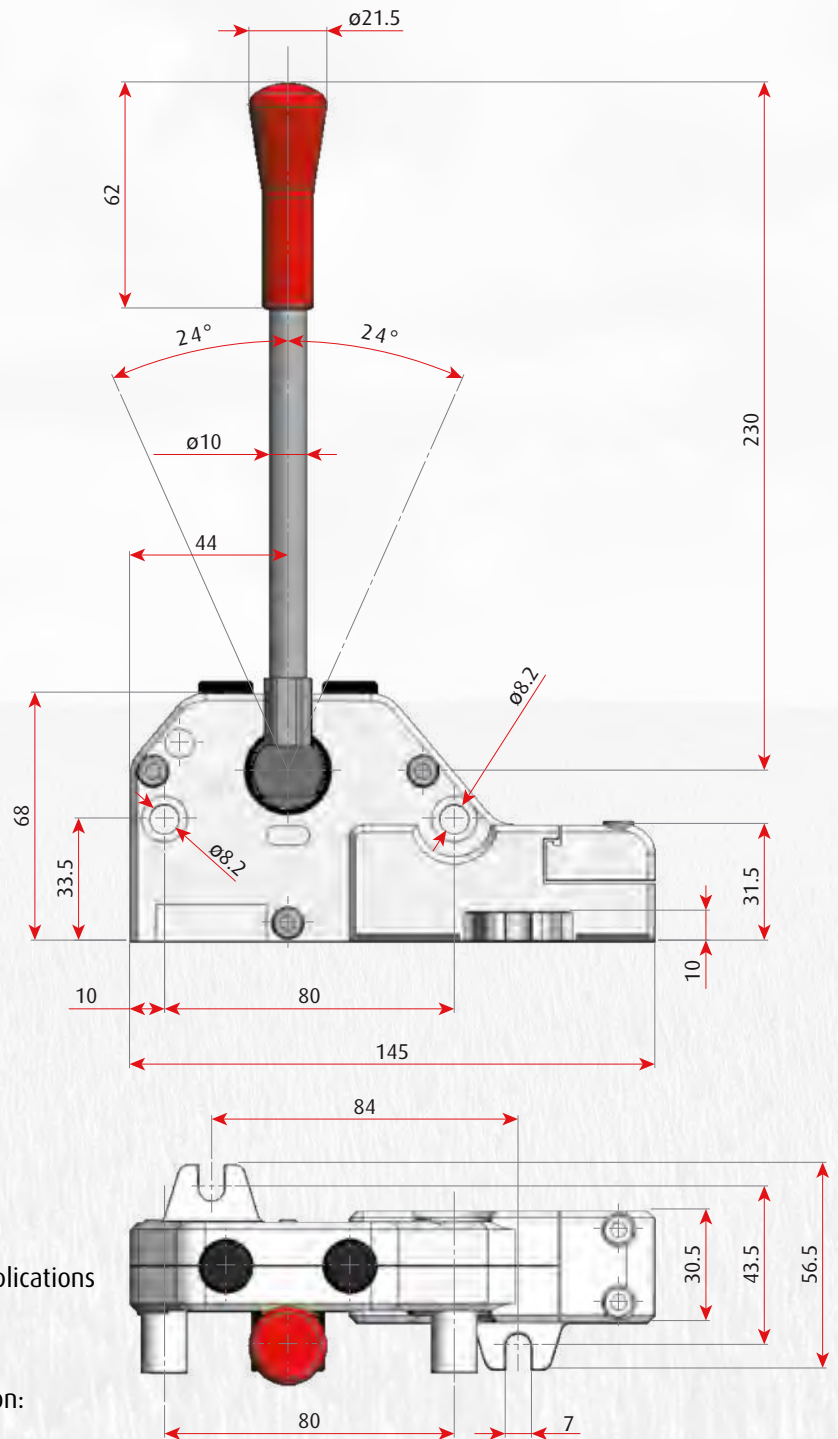

SPECIFICATION

- Possibility to mount side by side for multi axes applications
- Cable's stroke: +/- 16 mm
- 450 N maximum working load
- Available with several options and their combination:
 - Tuning of the stroke
 - Anti reversal
 - Locking function

TUNING OF THE END OF STROKE

To modify the end of stroke, it is necessary to remove the two black plastic covers and tune the screws placed inside. Two screws regulate independently the forward and reverse lever's stroke. To increase the stroke, rotate the screw clockwise; to reduce the stroke, rotate the screw counter clockwise. Maximum stroke is +/- 16 mm.

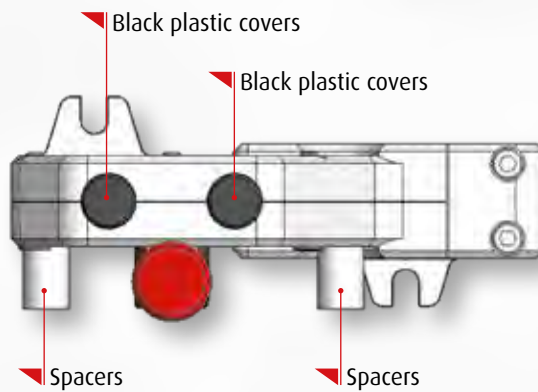

SPACERS

Levers series 1500 are available with or without spacers. Spacers are necessary for multi axle applications.

MULTI-AXLE KIT

Rods with different lengths allow to assembly up to 7 levers 1500 side by side. The result is a compact block with a different number of levers.

Description	Rod length (mm)	Kit code
Kit for 2 levers	L=98	0-0099.21.24.01
Kit for 3 levers	L=138	0-0099.21.24.02
Kit for 4 levers	L=178	0-0099.21.24.03
Kit for 5 levers	L=218	0-0099.21.24.04
Kit for 6 levers	L=258	0-0099.21.24.05
Kit for 7 levers	L=298	0-0099.21.24.06

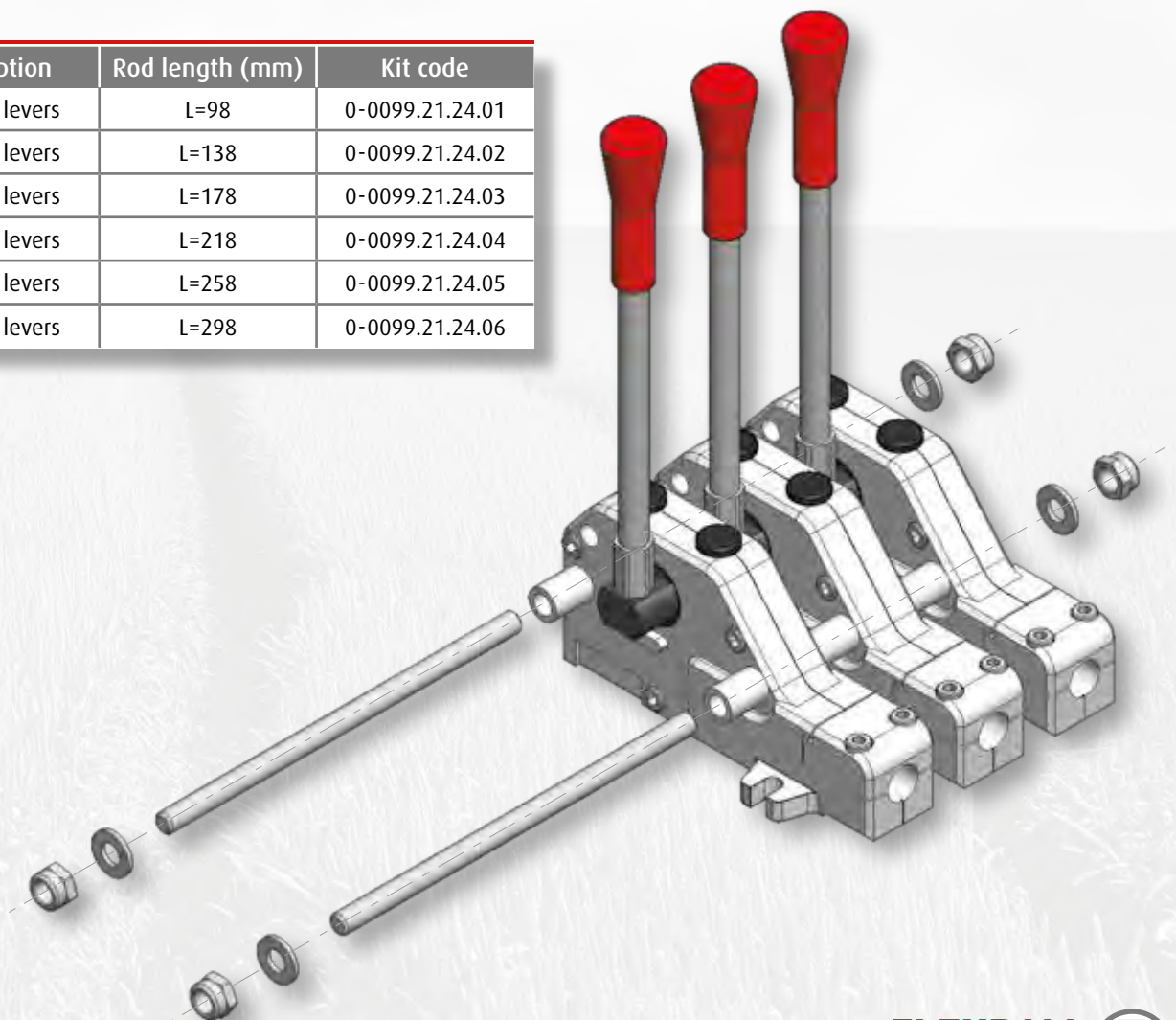

ANTI-REVERSAL FUNCTION

The lever can be moved only in one direction, depending on how is mounted the anti-reversal device. As shown in the pictures here below, in mounting case "A" the lever can just move forwards while in mounting case "B" the lever can just move reverse.

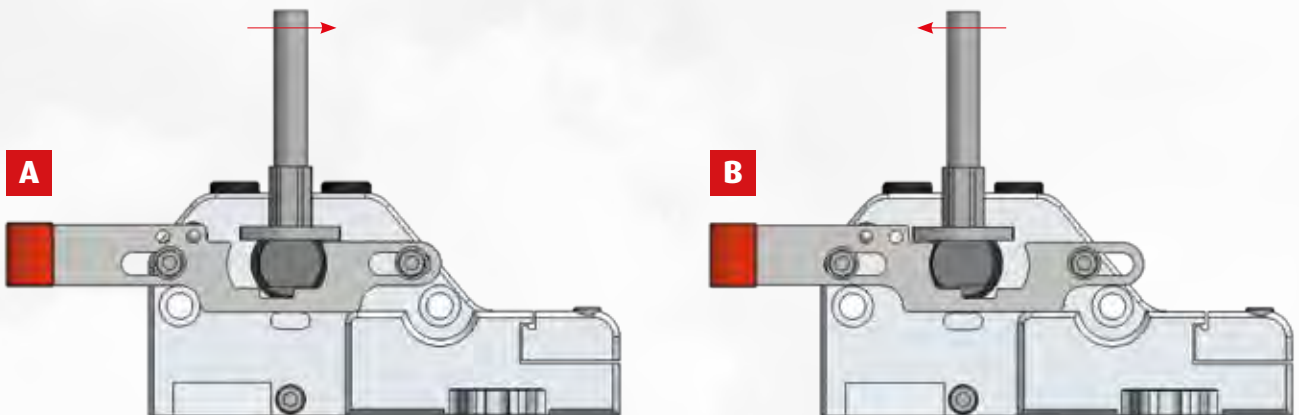

Lever 1500 can be ordered already with the anti-reversal built-in function. Alternatively it is possible to implement anti-reversal function on a standard 1500 lever by ordering the anti-reversal kit. The code for such a kit is 0-1500.06.01.00.

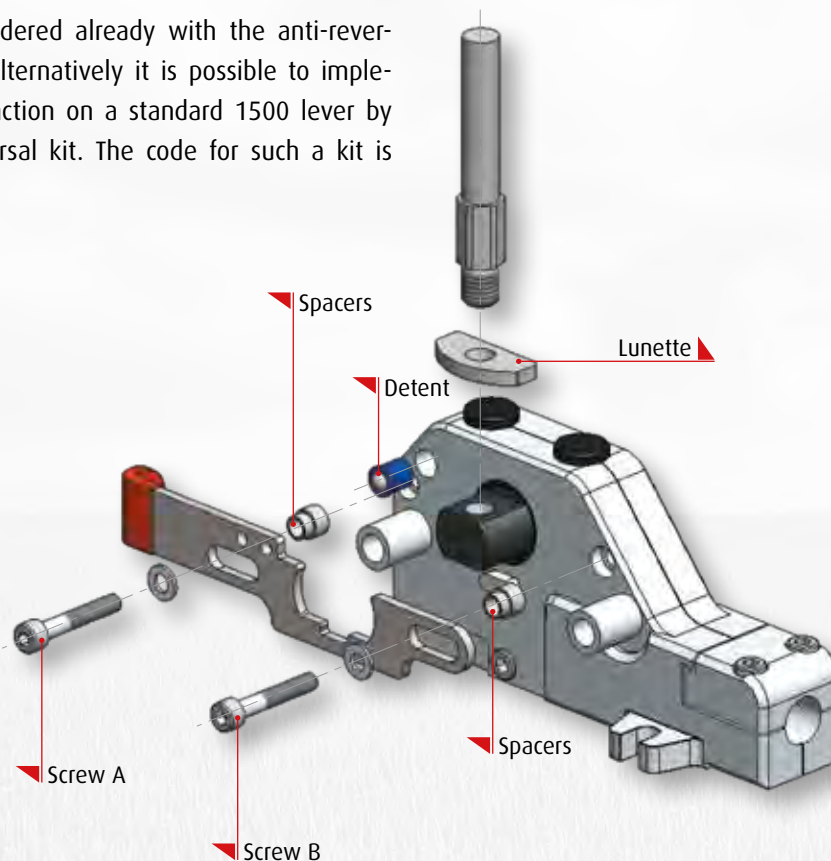

MOUNTING OF THE ANTI-REVERSAL DEVICE

1. Unscrew the lever's stick
2. Place the lunette as shown in the picture and screw again the lever's stick
3. Loosen screws A and B
4. Insert the detent in its housing
5. Position the spacers onto the holes inside the body and mount the anti-reversal device
6. Tighten again the screws A and B

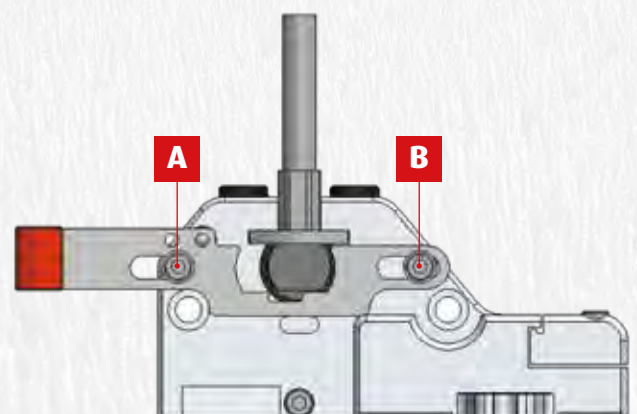

LOCK FUNCTION

Depending on the position of the locking device, the lever can be freely moved (case A) or it is locked in the central position (case B).

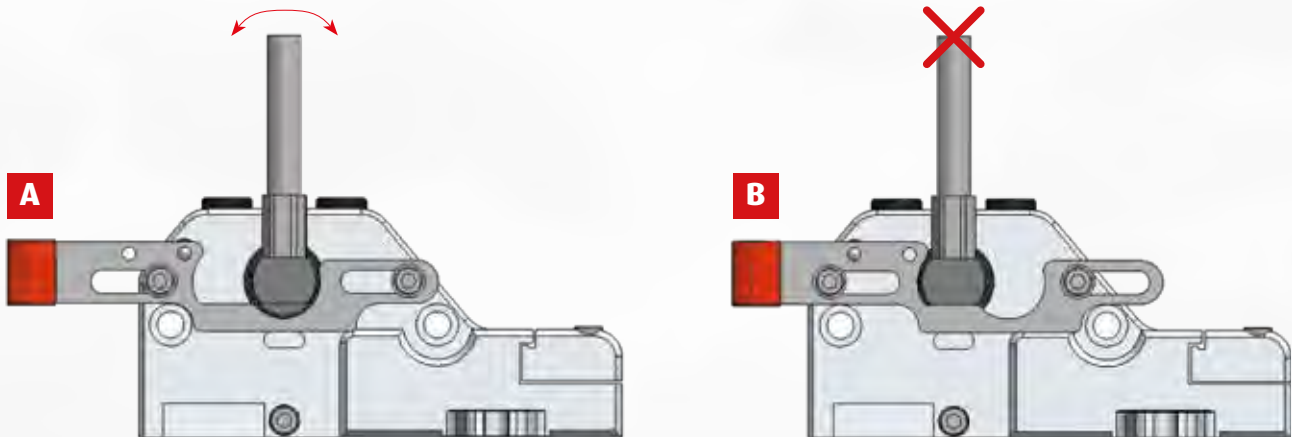

Lever 1500 can be ordered already with the lock function. Alternatively it is possible to implement the lock function on a standard 1500 lever by ordering the locking kit. The code for such a kit is 0-1500.06.00.00.

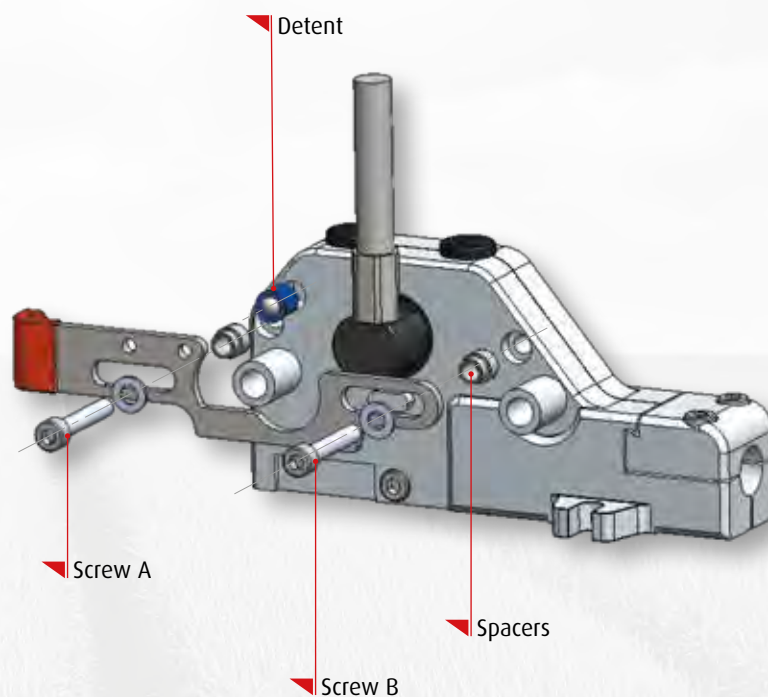

MOUNTING OF THE LOCK DEVICE

1. Loosen screws A and B
2. Insert the detent in its housing
3. Position the spacers onto the holes inside the body and mount the locking device
4. Tighten again screws A and B

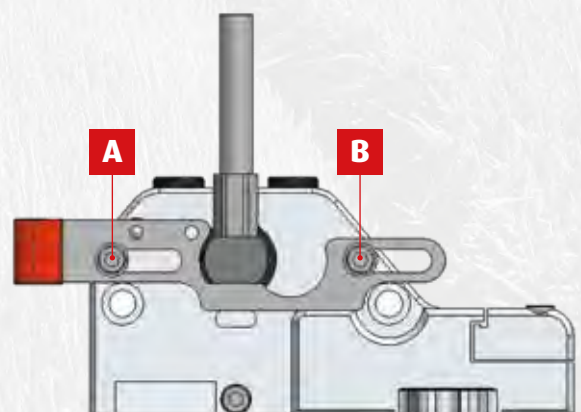

CODES

It follows the list of the codes for control lever series 1500 in different versions.

Spacers	Lever's stick length	End of stroke	Version	Code
With spacers	180	Without end of stroke	Standard	1501-100X
			With anti-reversal function	1501-101X
			With lock function	1501-102X
		With end of stroke	Standard	1501-110X
			With anti-reversal function	1501-111X
			With lock function	1501-112X
	230	Without end of stroke	Standard	1501-000X
			With anti-reversal function	1501-001X
			With lock function	1501-002X
		With end of stroke	Standard	1501-010X
			With anti-reversal function	1501-011X
			With lock function	1501-012X
Without spacers	180	Without end of stroke	Standard	1500-100X
			With anti-reversal function	1500-101X
			With lock function	1500-102X
		With end of stroke	Standard	1500-110X
			With anti-reversal function	1500-111X
			With lock function	1500-112X
	230	Without end of stroke	Standard	1500-000X
			With anti-reversal function	1500-001X
			With lock function	1500-002X
		With end of stroke	Standard	1500-010X
			With anti-reversal function	1500-011X
			With lock function	1500-012X

Note:

- "X" identifies the type of knob: 3 = ogival black knob, 5 = standard orange knob

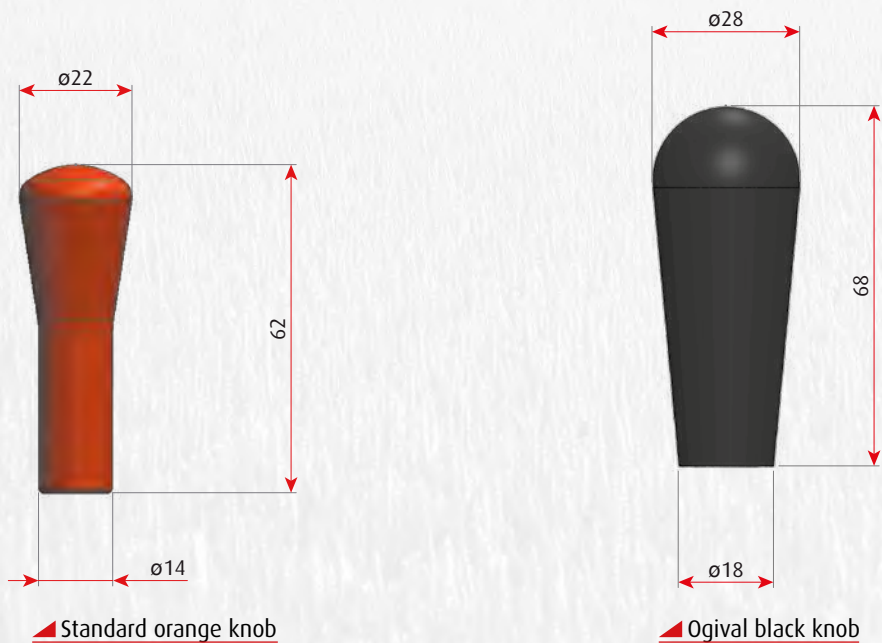

PUSH-PULL CABLES WHICH FIT WITH LEVER 1500

LEVER SIDE

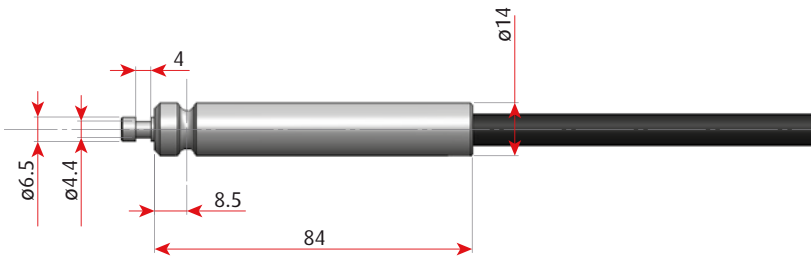

- The end fittings are represented with the cable at mid stroke position

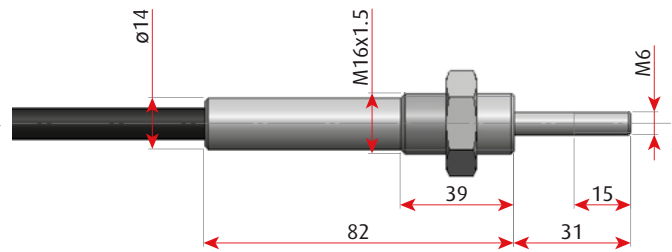

▲ Cable type 07E, code 971630*mmmm

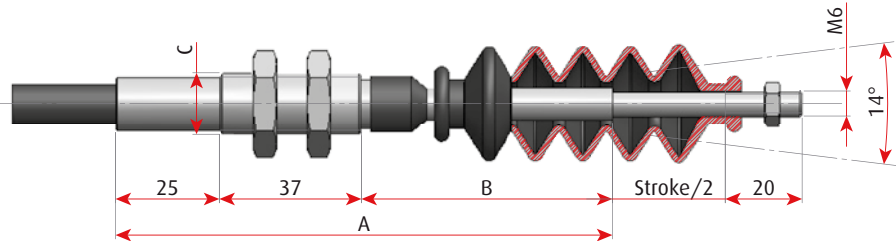

A	B	Thread (C)	Code
140	65	M14x1	271630*mmmm
		M16x1.5	271630-6*mmmm

HYDRAULIC DISTRIBUTOR SIDE

Mechanical Controls

2

1600

Single axis

It is made with an aluminium alloy body

Push-pull cable exits at 45 degrees with respect to the lever. It is used for the command of gears, stabilizers, brush cutters, agricultural machineries and hydraulic distributors in general.

SPECIFICATION

- Possibility to mount side by side for multi axles applications
- Cable's stroke: +/- 16 mm
- 300 N maximum working load

CODES

Version	Code
Basic lever without spring	1600
With return to centre spring (self centering)	1600.01
With syringe to lock the lever in the centre	1600.02

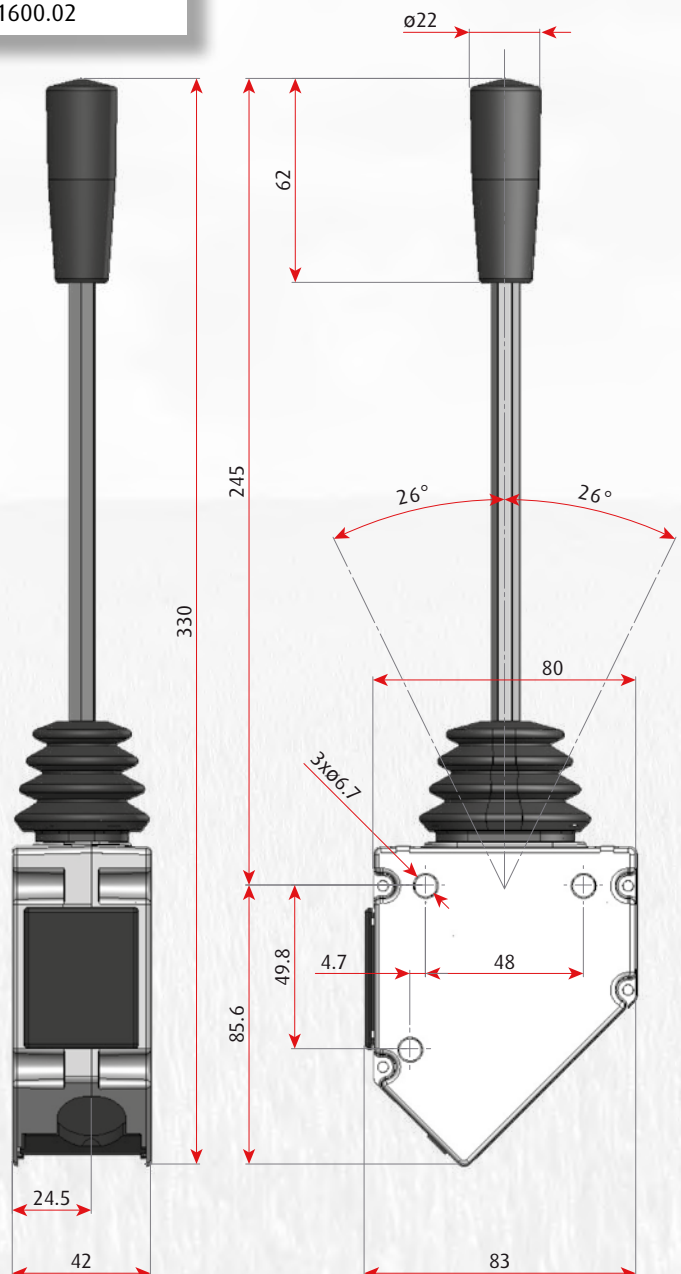

PUSH-PULL CABLES WHICH FIT WITH LEVER 1600

LEVER SIDE

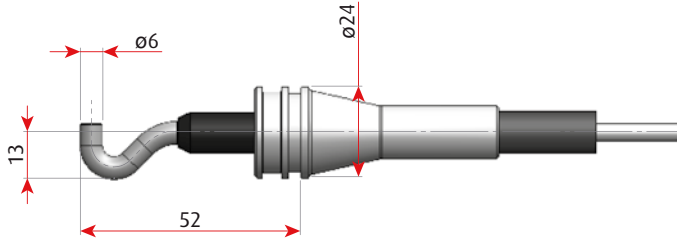

- The end fittings are represented with the cable at mid stroke position

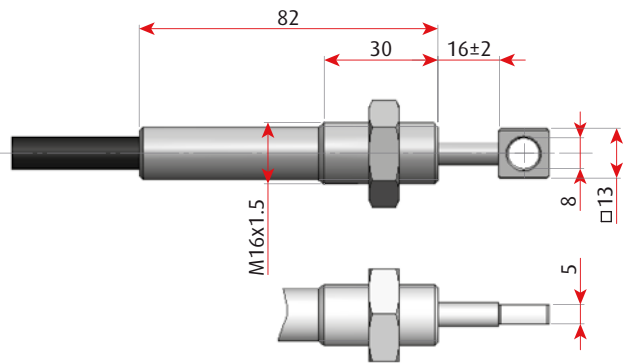

▲ Cable type 07E, code 0075921*mmmmm

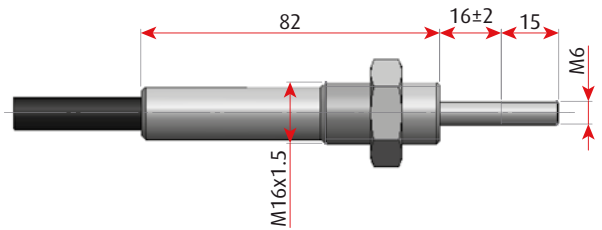

▲ Cable type 07E, code 0075920*mmmmm

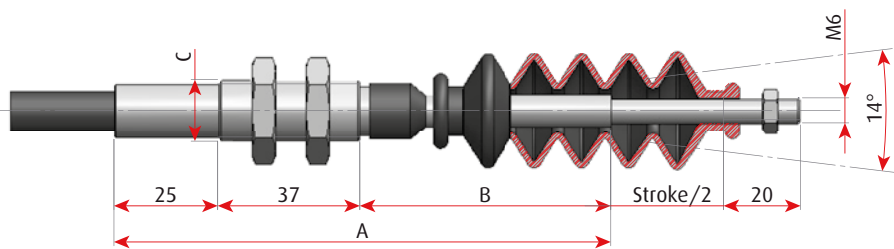

A	B	Thread (C)	Code
185	110	M14x1	0075922*mmmmm
		M16x1.5	0075922-6*mmmmm

HYDRAULIC DISTRIBUTOR SIDE

2000 Joystick

It is a series of joysticks made in aluminium alloy which are particularly appropriate for heavy duty applications in agriculture and construction equipment sectors

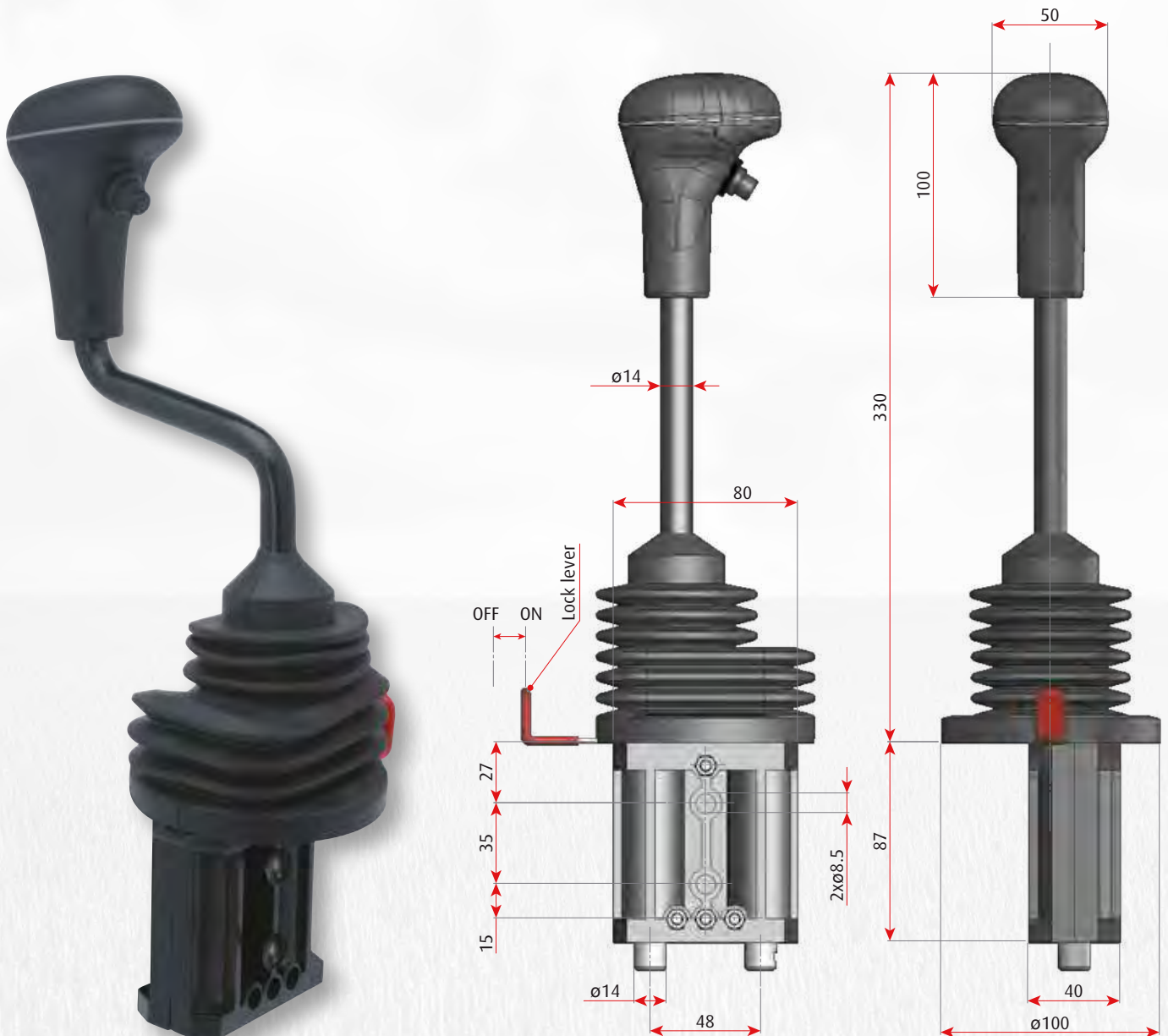

SPECIFICATION

- Stroke: +/- 14 mm
- Working load: 400 N
- Lever ratio: 14:1 (with standard lever length)
- Automatic return to centre
- Locking lever at centre
- Colour: black

CODES

Joystick version	Code
Lever's stick straight l = 330 mm, standard	1036-1
Lever's stick straight, short	1036-12
Lever's stick with "Z" profile	1036-16

Note:

Joystick 2000 as standard is equipped with the anatomic handle. The anatomic handle can be configured as a bare handle or with 1 push button or with 1 lever switch (see page 103 of "Industrial Products" catalogue).

PUSH-PULL CABLES WHICH FIT WITH JOYSTICK 2000

- The end fittings are represented with the cable at mid stroke position

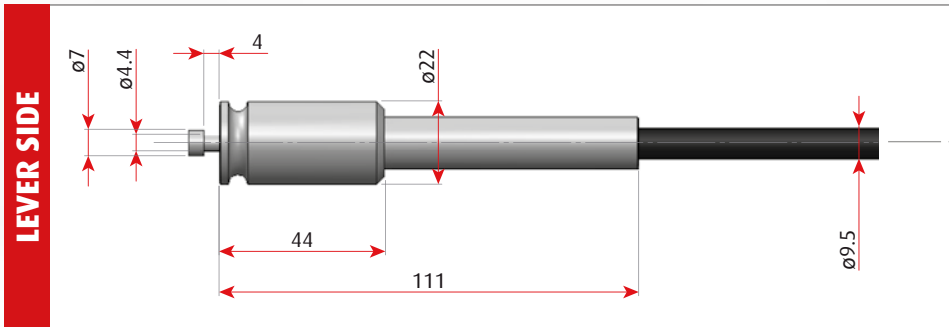

LEVER SIDE

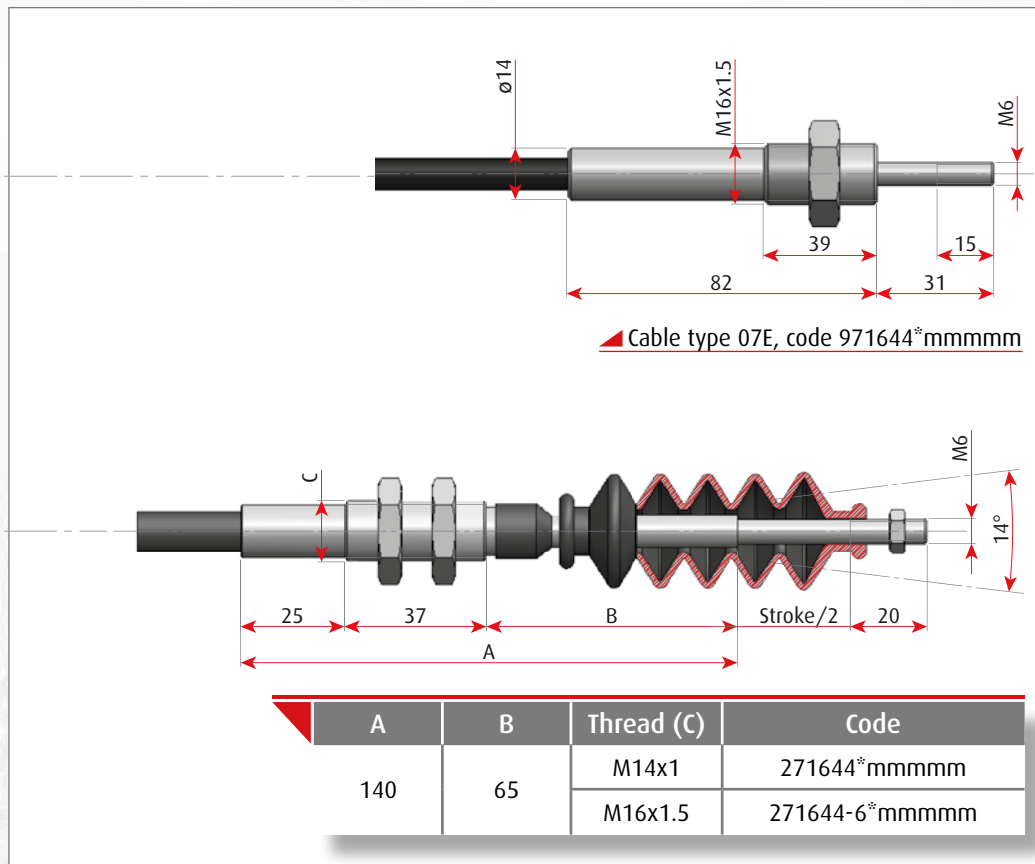

HYDRAULIC DISTRIBUTOR SIDE

A	B	Thread (C)	Code
140	65	M14x1	271644*mmmm
		M16x1.5	271644-6*mmmm

2500 Joystick

This series of joystick, aluminium made, is available in a very high number of versions which can fulfil any designer's requirements

It can be equipped in combination with a great number of handles with a variety of switches and push buttons.

Thanks to its construction based on long axles which slide into the two chambers of its aluminium body, movements are very precise and without friction, even in case of very heavy loads.

The self centring springs return the lever's stick always to central position, as soon as the stick is released; this gives

the operator the feeling that everything is always under control and at the right place.

Joystick series 2500 can be fixed either on a wall or on a bracket and it is equipped with a red lock lever for an easy identification. The connection of the cable on the joystick is very easy and safe; this operation can be done also when the joystick is already fixed on the machine.



Joystick 2500 with straight
▲ lever and standard handle



Joystick 2500 with bent
▲ lever and standard handle



Joystick 2500 with
▲ multifunctional handle



Joystick 2500 with
▲ ergonomic handle

SPECIFICATION

- Stroke: +/- 13 mm
- Working load: 400 N
- Lever ratio: depend on the stick length and type
- Automatic return to centre
- Locking lever at centre
- Colour: black

CORRELATION BETWEEN LEVER'S AND CABLE'S MOVEMENTS

Moving the lever, you operate the internal slides which move the cables and consequently the hydraulic distributor. With reference to the below picture n. 1, when you move the lever right, cable B pulls and when you move the lever left, cable B pushes. In picture n. 2, when you move lever left, cable A pulls and when you move lever right, cable A pushes. Picture 3 exemplifies the combined movements of the two cables when the lever is in intermediate positions.

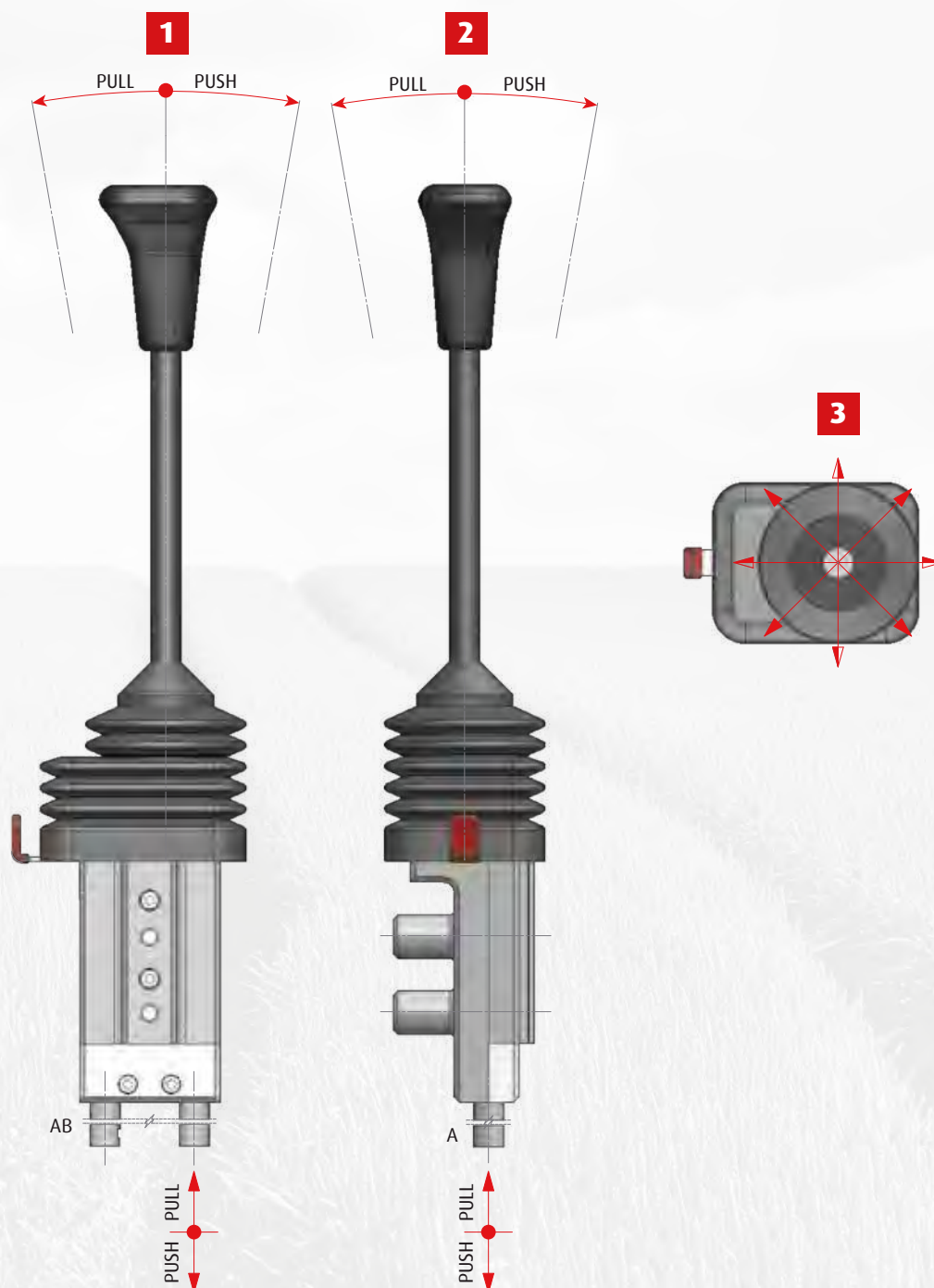

JOYSTICK 2500 WITH STRAIGHT LEVER AND STANDARD HANDLE

Lever length	Lever ratio	Code
275 mm	9.5:1	1036-8-01
330 mm	11.5:1	1036-8-02

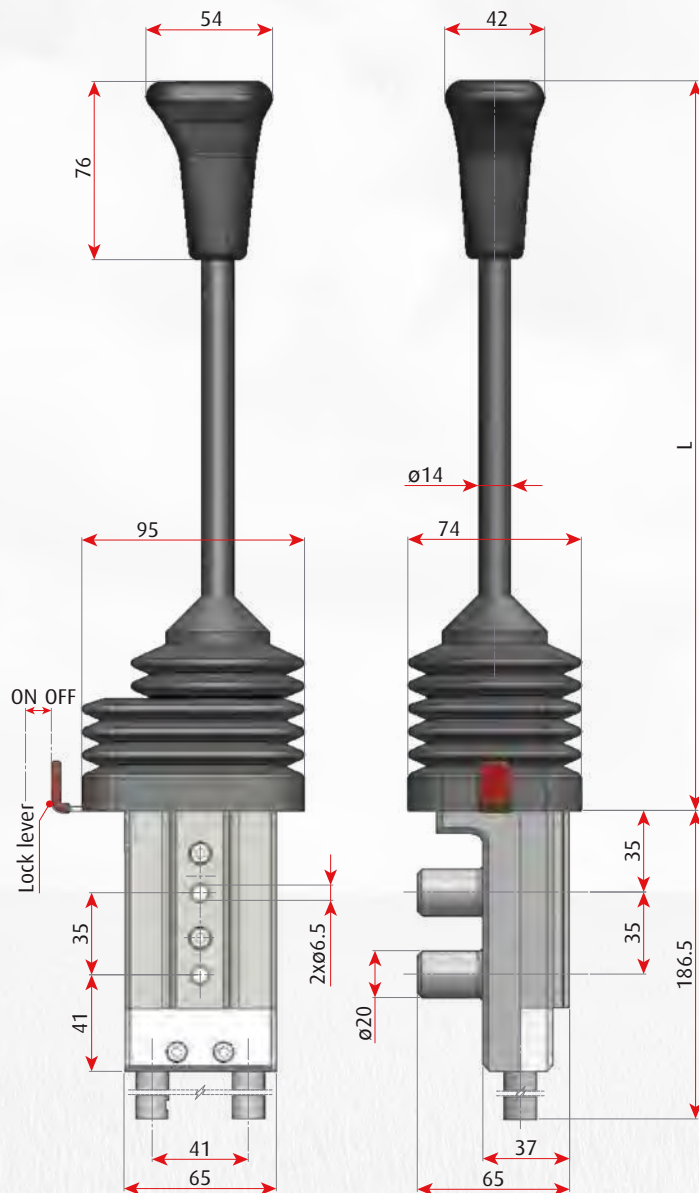

JOYSTICK 2500 WITH BENT LEVER AND STANDARD HANDLE

It follows the dimensions of the standard lever. Upon customer's request, lever's length and bending angles can be modified.

Lever length	Lever ratio	Length A	Length B	Angle C	Code
275 mm	9.5:1	47 mm	47 mm	45°	1036-8-03

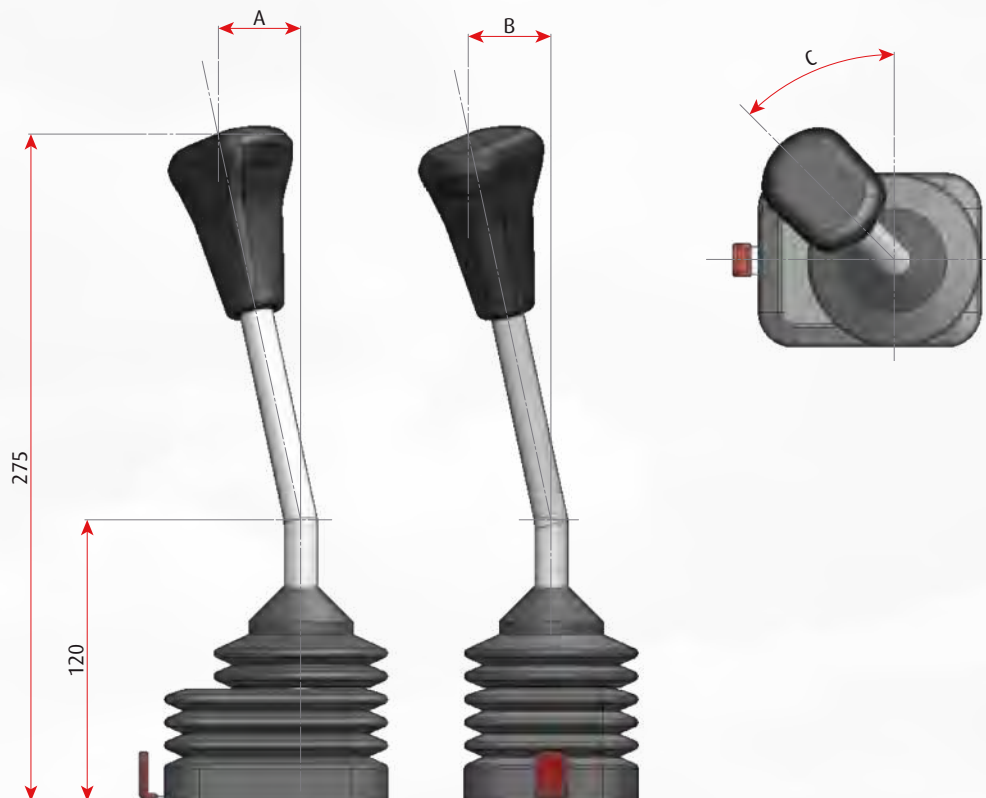

JOYSTICK 2500 WITH ANATOMIC HANDLE WITH 1 SWITCH

Standard lever length is 320 mm but it can be customized to different lengths. It is also available in the bent version.

Lever length	Lever ratio
320 mm	11:1

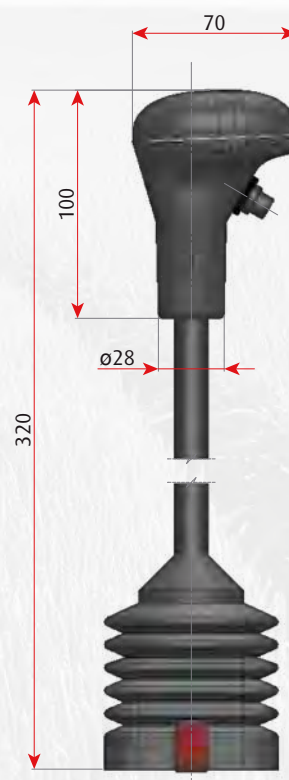

JOYSTICK 2500 WITH MULTIFUNCTIONAL HANDLE

Standard lever length is 320 mm but it can be customized to different lengths. It is also available in the bent version. For detailed information on the possible configuration of the handle with its several switches, go to page 96 of "Industrial Products" catalogue.

Lever length	Lever ratio
320 mm	11:1

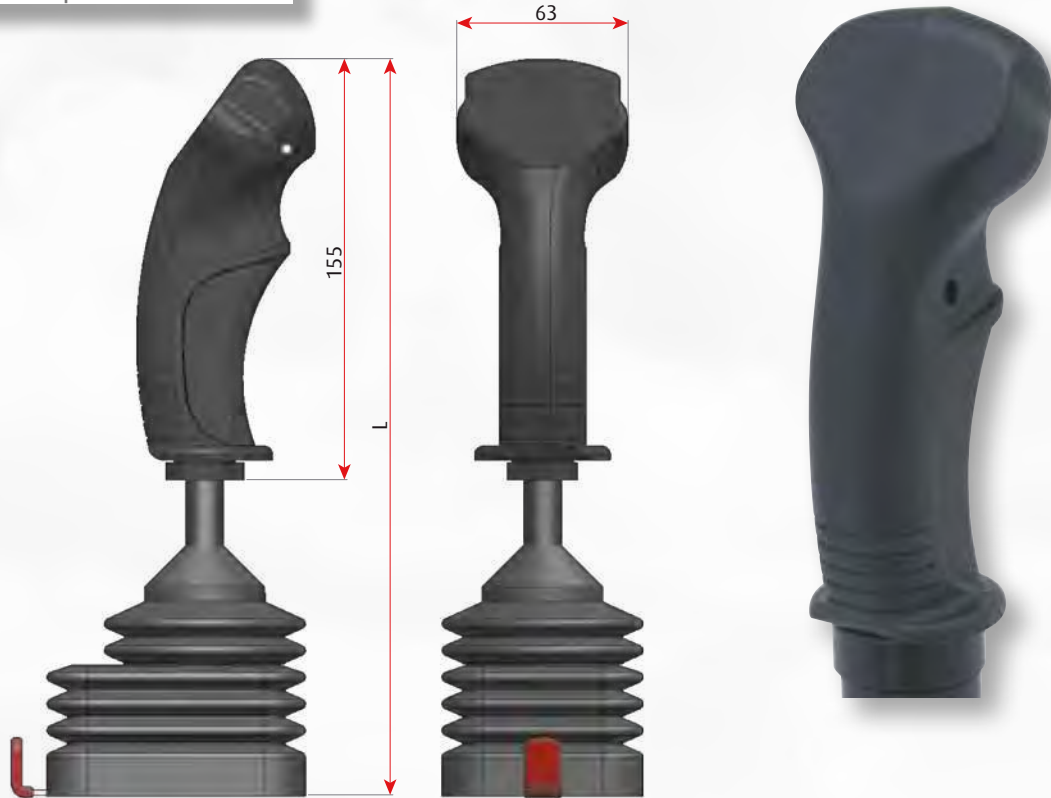

JOYSTICK 2500 WITH ERGONOMIC HANDLE AND A HIGH VARIETY OF SWITCHES

This joystick version has a big handle which reduces the operator's fatigue during long working period. It can be configured with up to 5 push buttons, placed mainly on the front but also on the back of the handle.

The prefix family code is: 1036-8-01-

In chapter 7 it will be given full information of the handle's versions with their suffix codes.

The combination of prefix and suffix determines the full joystick's code.

Lever length	Lever ratio	Code basic version *
280 mm	9.5:1	1036-8-01-

Note:

“*” For all the versions available see pages 100 and 101 of "Industrial Products" catalogue.



PUSH-PULL CABLES WHICH FIT WITH LEVER 2500

LEVER SIDE

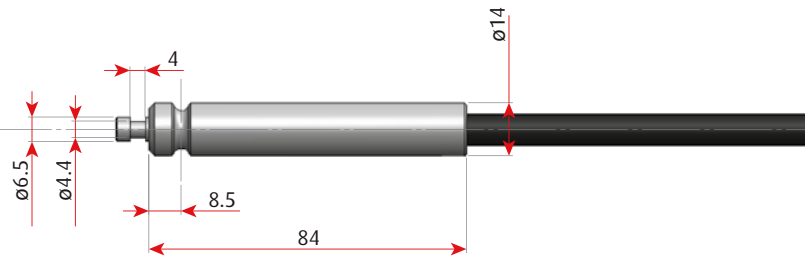

- The end fittings are represented with the cable at mid stroke position

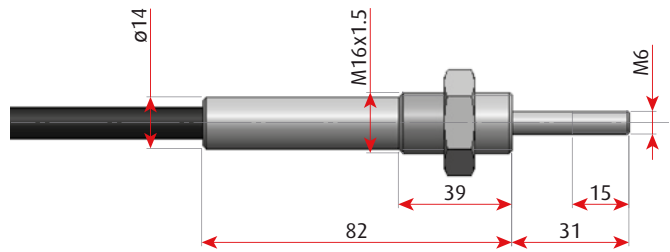

◀ Cable type 07E, code 971630*mmmm

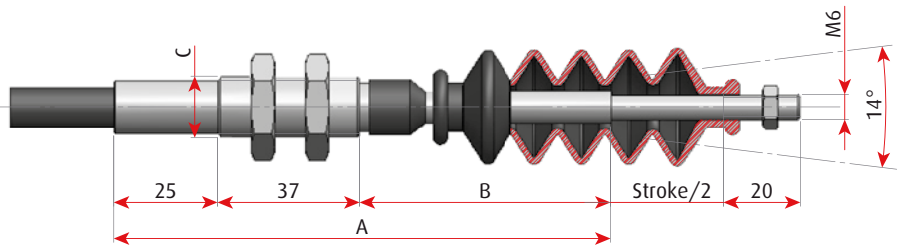

A	B	Thread (C)	Code
140	65	M14x1	271630*mmmm
		M16x1.5	271630-6*mmmm

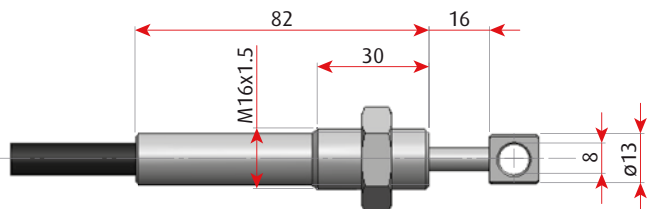

◀ Cable type 07E, code 0076200*mmmm

HYDRAULIC DISTRIBUTOR SIDE

Mechanical Controls

2



2800 Joystick

This series of economic joysticks is suitable for agricultural application such as front loaders

Thanks to its modular construction, it can be configured for any application's requirements like, for example, clockwise or counter clockwise with respect to cable movements. It is available with maximum 3 push buttons.

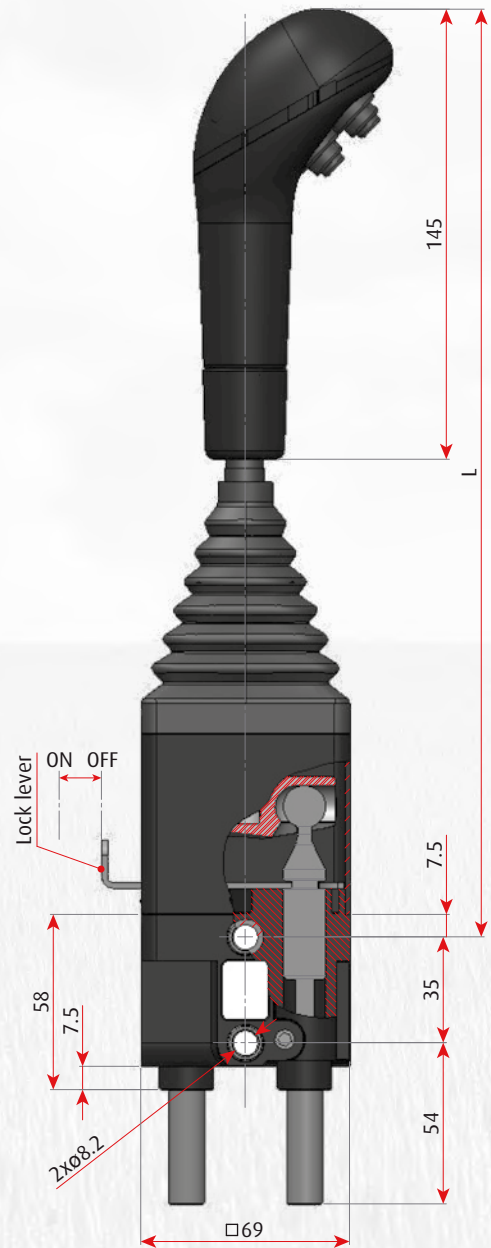

SPECIFICATION

- Lever length: either 295 or 345 mm
- Cable stroke: +/- 16 mm
- Lever ratio (depending on lever's length): either 6:1 or 7.5:1
- Lever stroke measured on the knob (depending on lever's length): either 200 mm (46°) or 250 mm (46°)

LOCK LEVER POSITION

It is possible to mount the lock lever on each of the 4 sides of the base of the joystick 2800. Depending on the fulcrum position are defined two different correlations between the movements of the lever and the movements of the push-pull cable: clockwise or counter clockwise.

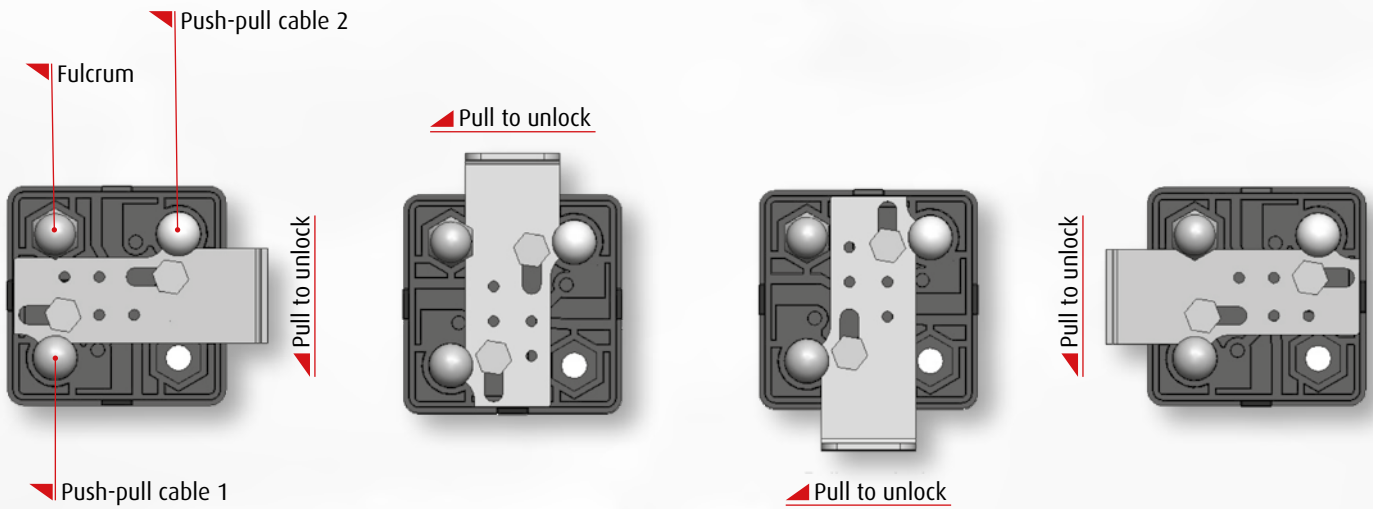

PUSH PULL CABLES MOVEMENTS WITH RESPECT TO LEVER'S DIRECTION

The following table describes the direction of the cables with respect to the movement of the lever.

Lever's direction	Cable 1 direction	Cable 2 direction	Rotation
A	Push	-	Clockwise
B	Pull	-	
C	-	Push	
D	-	Pull	
A	-	Pull	Counter clockwise
B	-	Push	
C	Pull	-	
D	Push	-	

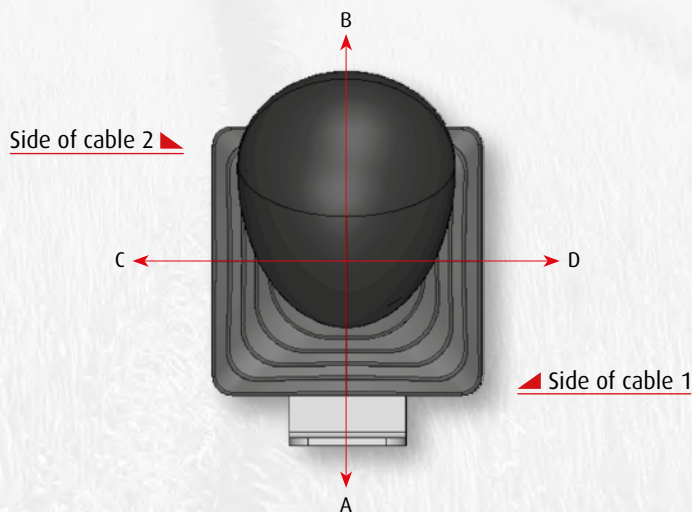

Joystick 2800 is delivered from the factory with the lock lever in closed position (like in the first above scheme). For different position of the lock lever, please contact your dealer or the factory.

HANDLE AND PUSH BUTTONS

The handle of joystick 2800 can be without or with up to 3 push buttons. Each switch can commutate a maximum current of 5 amps DC. In case of push buttons, the joystick is provided with a 4 poles electrical cable of a standard length of one meter.

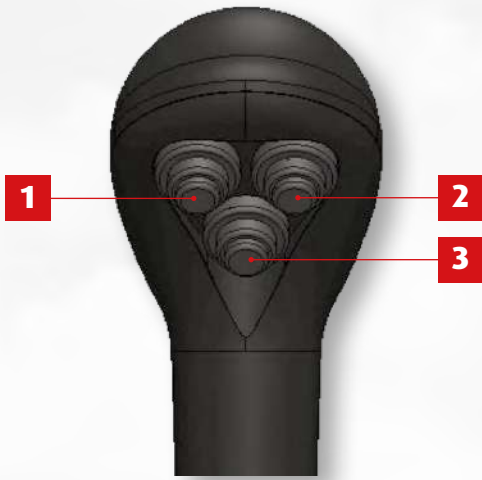

▲ Electrical wiring

Push button	Wiring colour
1	Black
2	Grey
3	Brown
Common wire	Blue

CODES

Lever length	Rotation	Number of push buttons	Code
295	Clockwise	Joystick without handle	1036-50-01
		0	1036-50-01-00R
		1	1036-50-01-01R
		2	1036-50-01-02R
		3	1036-50-01-03R
	Counter clockwise	Joystick without handle	1036-50-11
		0	1036-50-11-00R
		1	1036-50-11-01R
		2	1036-50-11-02R
		3	1036-50-11-03R
345	Clockwise	Joystick without handle	1036-50-02
		0	1036-50-02-00R
		1	1036-50-02-01R
		2	1036-50-02-02R
		3	1036-50-02-03R
	Counter clockwise	Joystick without handle	1036-50-12
		0	1036-50-12-00R
		1	1036-50-12-01R
		2	1036-50-12-02R
		3	1036-50-12-03R

PUSH-PULL CABLES WHICH FIT WITH JOYSTICK 2800

- The end fittings are represented with the cable at mid stroke position

LEVER SIDE

HYDRAULIC DISTRIBUTOR SIDE

▲ Cable type E3, code 0035730-mmmmm

Cable type E3, code 00341100-mmmmm
 Cable type 07E, code 00741100*mmmmmm
 ▲ Cable type 017, code 01041100-mmmmm

▲ Cable type 017, code 0175940-mmmmm

2900 Joystick

This series of economic joysticks, made of aluminum, is suitable for agricultural application such as front loaders. Thanks to its modular construction, it can be configured for any application's

requirements like clockwise or counter clockwise with respect to cable movements. It is available with maximum 7 push buttons, either high current and low current.

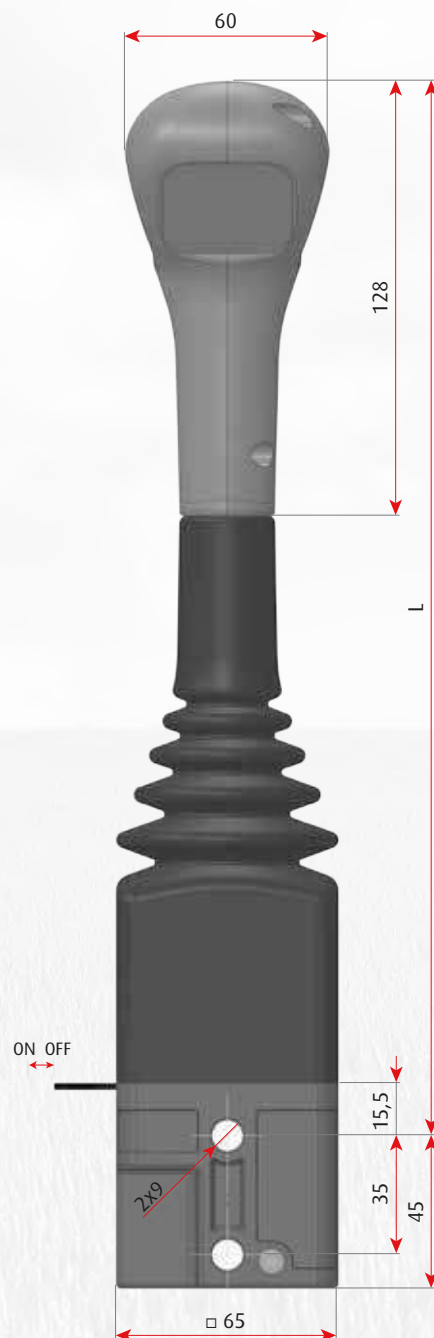

SPECIFICATION

- Cable stroke: +/-14 mm
- Lever ratio (depending on lever's length): either 6,5:1
- Lever angle: +/-23°

LOCK LEVER POSITION

It is possible to mount the lock lever on each of the 4 sides of the base of the joystick 2900.

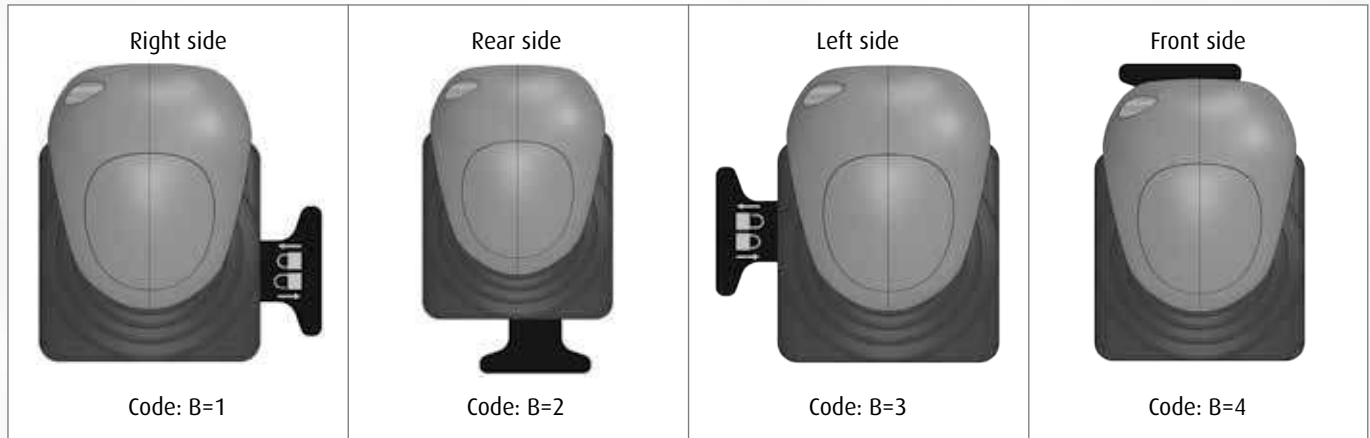

HANDLE AND PUSH BUTTONS

The handle of joystick 2900 can have up to 7 push buttons, either high current and low current, according to the table here below. Electrical cable standard length is 2 meter.

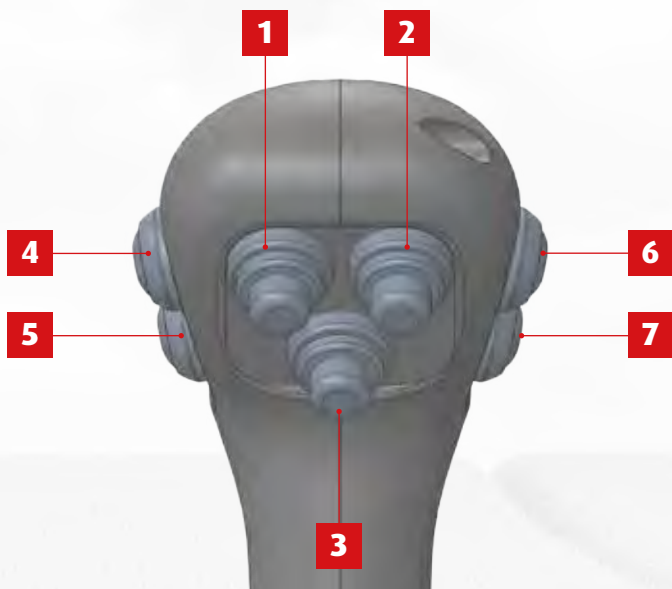

Ref	Push-button high current (4 A)	Push-button low current (400 mA)
1	X	X
2	X	X
3	X	X
4		X
5		X
6		X
7		X

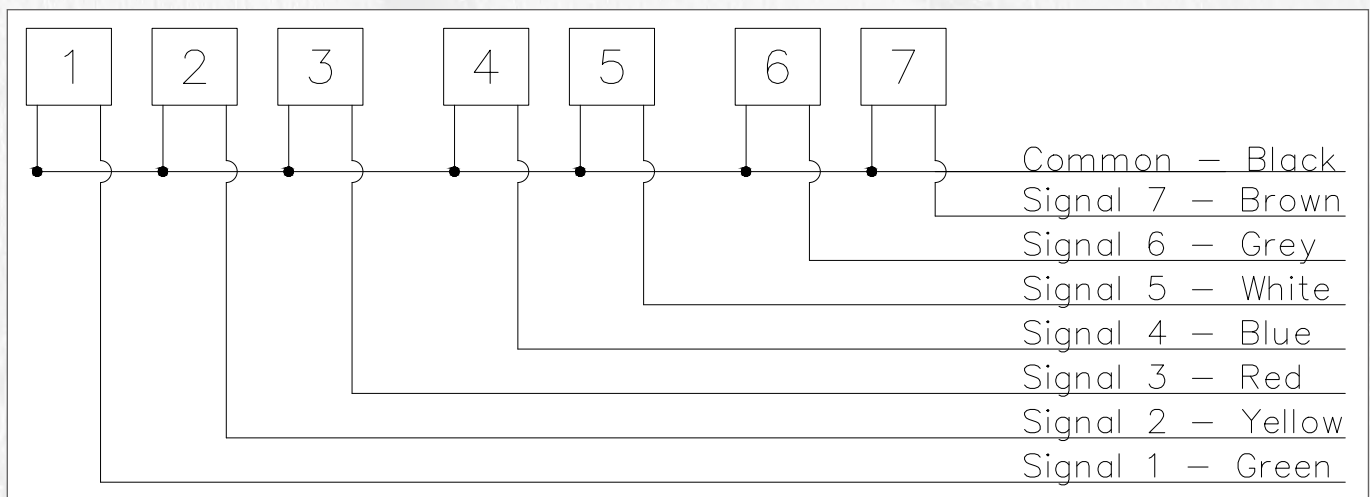

CODINGSYSTEM

DEVICE					BLOCK LEVER	STICK LENGTH	HANDLE		PUSH-BUTTON			SPECIAL CUSTOM PROJECTS	
D	D	D	D	-	B	L	K	.	P1	P2	.	X	X

D	D	D	D
---	---	---	---

define the product and the joystick version:

DDDD = 2900 standard version

B

defines the lock lever position:

B = 1 right side

B = 2 rear side

B = 3 left side

B = 4 front side

L

defines the length of the stick:

L = 0 no stick

L = 1 for L = 310 mm

L = 2 for customized length

K

defines the type of handle (for the handles please refer to chapter 7):

K = 0 without handle

K = 1 handle type 1705 (standard)

K = 2 handle type 1710 (anatomic)

K = 3 handle type 1715 (rear)

K = 4 handle type 1721 (rear grey)

K = 5 handle type 1720 (rear black)

K = 6 handle type 1725 (ergonomic)

K = 7 handle type 1730 (ergonomic XL)

P1	P2
----	----

define the number and type of push buttons

P1 = number of push buttons low current (400 mA)

P2 = number of push buttons high current (4 A)

X	X
---	---

numbering system from 0 to 99 is used to define special projects, cable length, type of connector, special push buttons and their position, dead man function, etc...

PUSH-PULL CABLES WHICH FIT WITH JOYSTICK 2800 AND 2900

LEVER SIDE

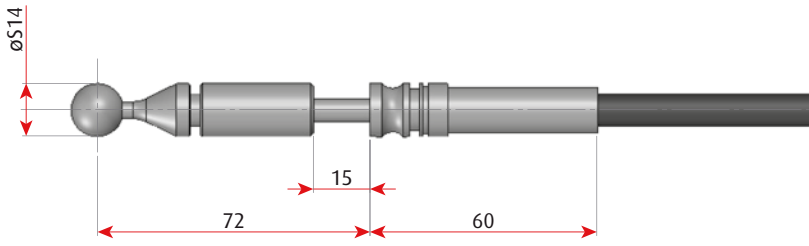

- The end fittings are represented with the cable at mid stroke position

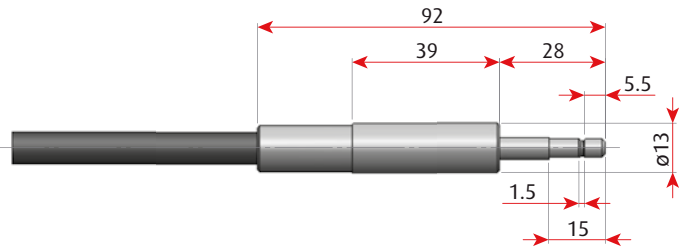

◀ Cable type E3, code 0035730-mmmmm

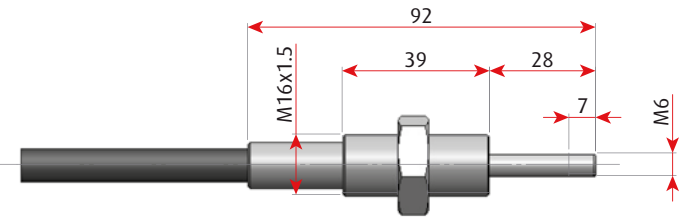

Cable type E3, code 00341100-mmmmm
 Cable type 07E, code 00741100*-mmmmmm
 ▶ Cable type 017, code 01041100-mmmmm

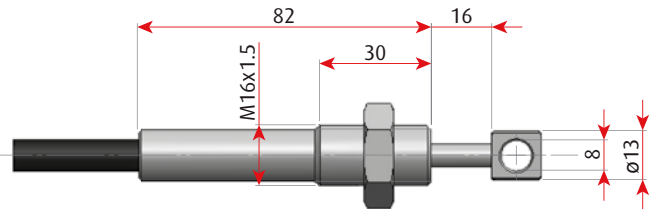

▶ Cable type 017, code 0175940-mmmmm

HYDRAULIC DISTRIBUTOR SIDE

Mechanical Controls

2



CONNECTING KITS

It is available a wide range of adaptation kits to connect our control cables to the majority of the hydraulic distributors available on the market.

Connecting kits with separate flange

LEGEND

- 1 Push-pull cable with hub M16x1.5 and rod M6
- 2 Nut M16x1.5
- 3 Flange
- 4 Aluminum connection to the hydraulic distributor
- 5 Pin (for full description refer to next page)
- 6 Connection to the hydraulic distributor spool (for full description refer to next page)

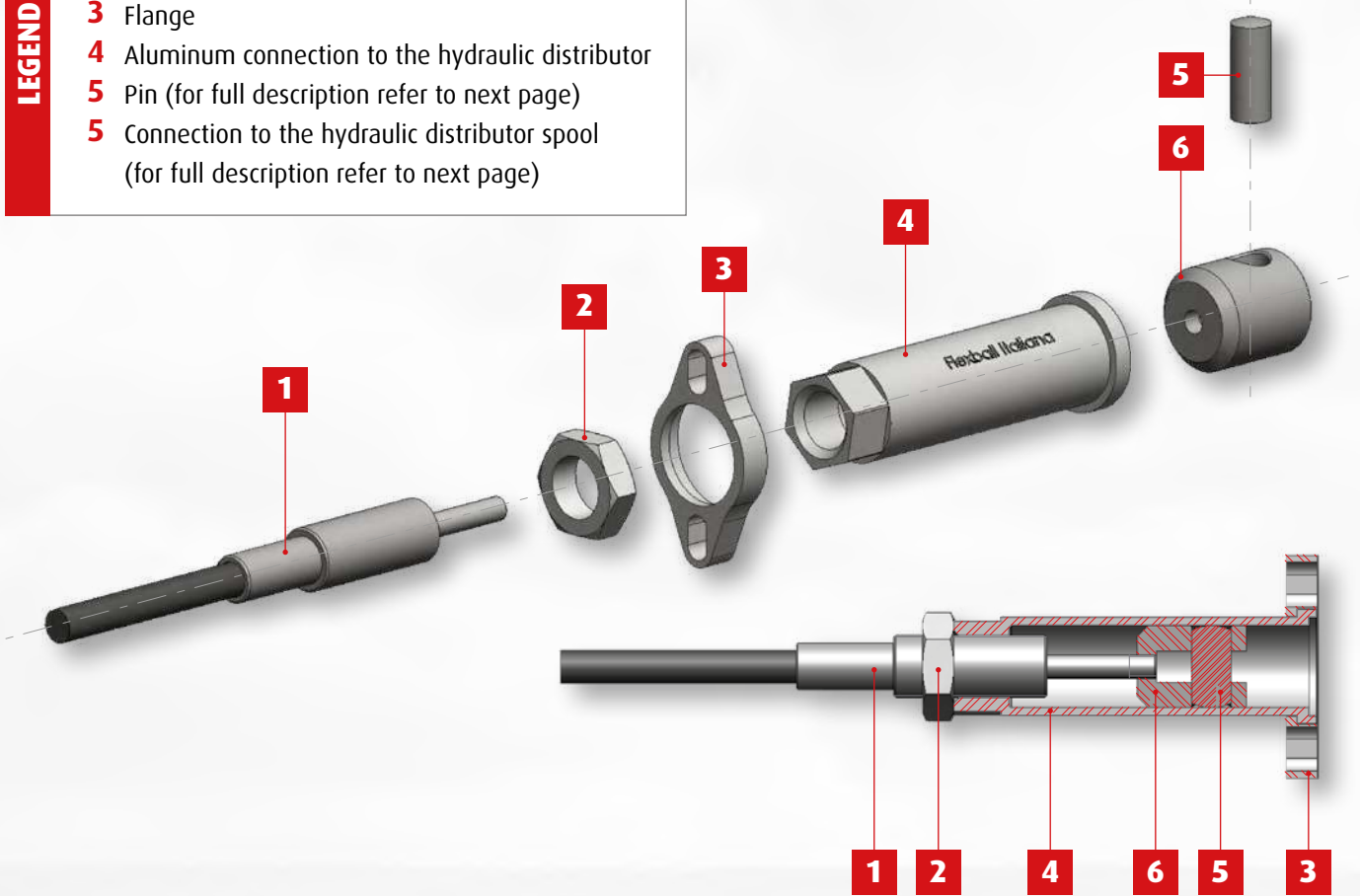

Aluminium connection tube

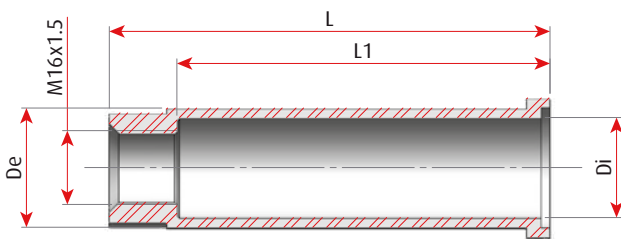

Code	Di	De	L	L1
D-0099.30.01.13	21	29	92.5	78.2

Aluminium flange

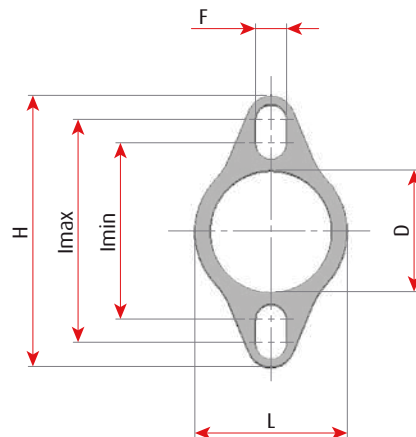

Code	D	F	H	Imin	Imax	L
D-0099.30.01.12	25.2	5.6	46	33.8	37.3	33
D-0099.30.02.13		6.5	57	40	46.8	34

Connecting kits with integrated flange

LEGEND

- 1 Push-pull cable with hub M16x1.5 and rod M6
- 2 Nut M16x1.5
- 3 Locking nut M22x1,5
- 4 Cut insert
- 5 Connection with integrated flange
- 6 Connection to the hydraulic distributor spool
- 7 Pin

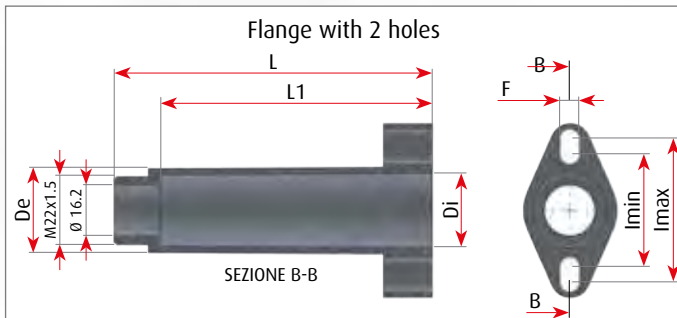
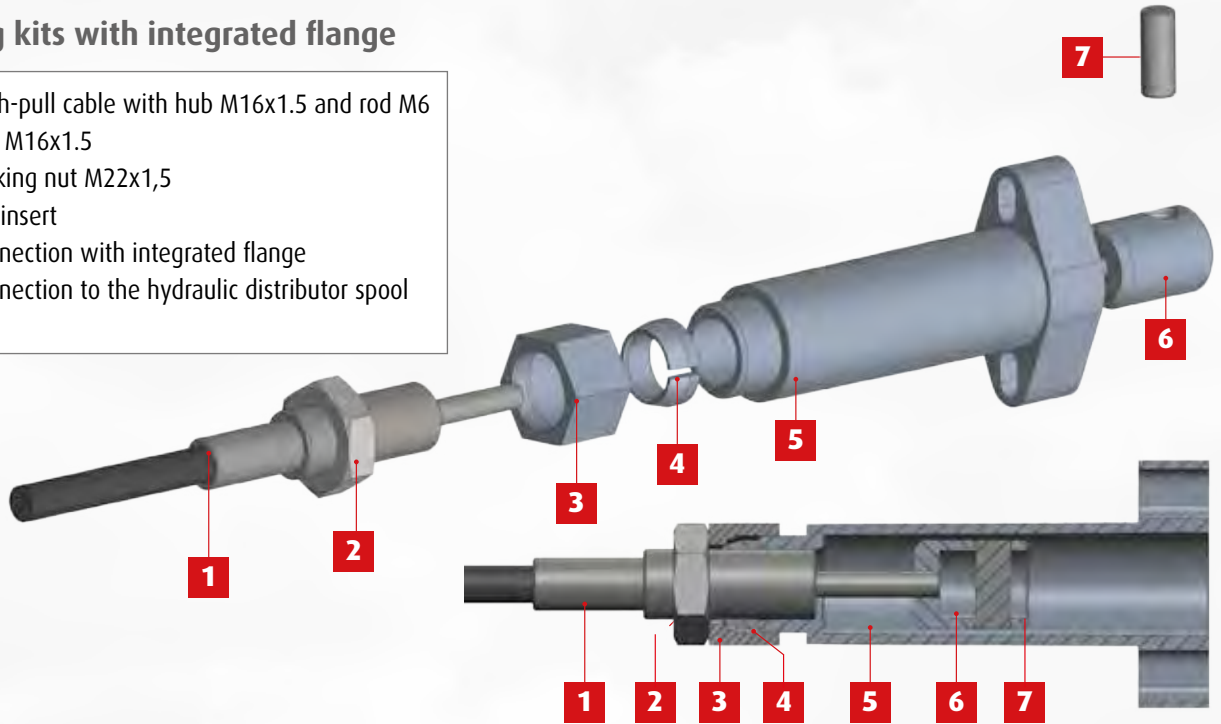

Code	De	Di	L	L1	F	Imin	Imax
D-0099.30.36.46	27	22.5	102	87	6,2	36	46

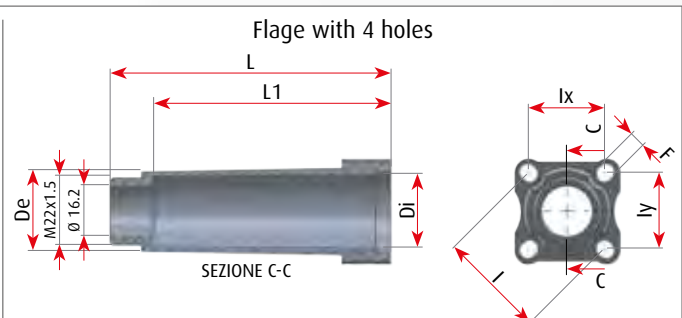

Code	De	Di	L	L1	F	I	Ix	Iy
D-0099.30.01.19	28	22.5	90	76	5,2	34,6	24,5	24,5
D-0099.30.01.23	27	22,5	102	87	5,5	39	26	29

Connection to the valve spool

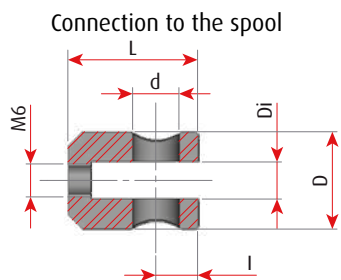

Code	D	d	Di	L	I
D-0099.30.00.01	20	6	15.5	26	8
D-0099.30.00.08	20	8		26	8
D-0099.30.00.25	20	7-9		26	8

Pin

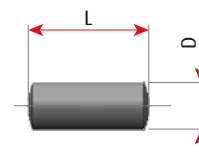

Code	D	L
D-0099.30.06.02	6	19
D-0099.30.04.04	8	19
D-0099.30.04.05	9	19



Heavy duty controls

SMALL/MEDIUM SIZE



E95



103

BIG SIZE



561



901



920 and 930

MULTI FUNCTION LEVERS



1068



ETC

E95

Small/medium size

Series of control levers with robust and essential design based on rack and pinion mechanism

This lever, which is indicated for heavy duty applications, is available in plane or swinging version, with or without adjustable friction, with or without detents in neutral and in many other positions. In case, E95 can be customized for the specific application. Neutral and reverse positions can be electrically signalled via micro-switch or via inductive sensor.



PLANE



SWINGING WITH NEUTRAL DETENT

TECHNICAL FEATURES

- It is possible to connect either push-pull or Flexball cables
- Different mounting positions: either side or top
- Maximum stroke: 85 mm
- Maximum working load (on the cable): 1000 N
- Lever ratio: 7.3:1
- Electrical signalling of the lever's position via micro-switch or via inductive sensor

DIMENSIONS

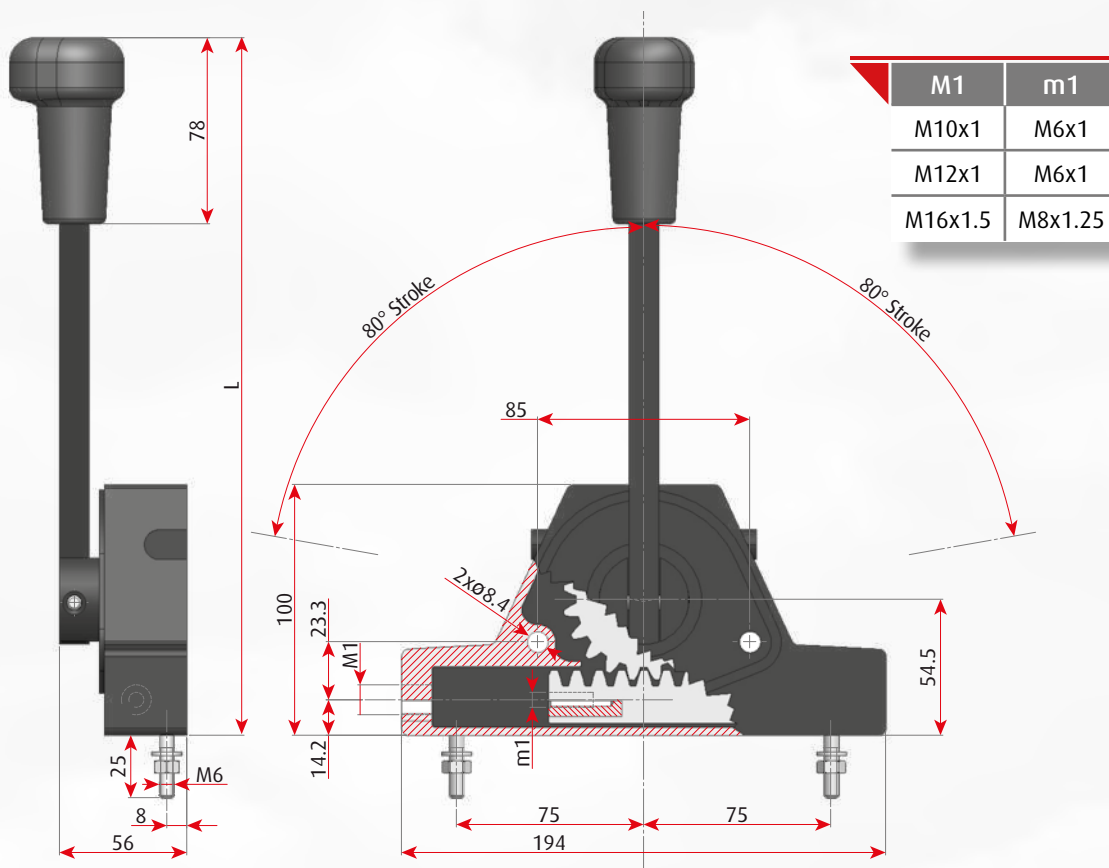

E95 SWINGING WITH NEUTRAL DETENT

When the lever is in the central position, the pin is inside the hole of the tempered plate and the lever is safety locked. To disengage the lever, the operator must push the lever outward in order to exit the pin from the hole.

When the control lever is in neutral position, the pin on the lever is forced to enter the hole on the mask (detail A) by a spring mounted inside the lever mechanism. The lever is then locked in neutral position. To disengage the lever, it is sufficient to push the lever outwards forcing the pin outside the hole (picture 1). Once back in neutral position, the pin will be forced into the hole and the lever will be locked.

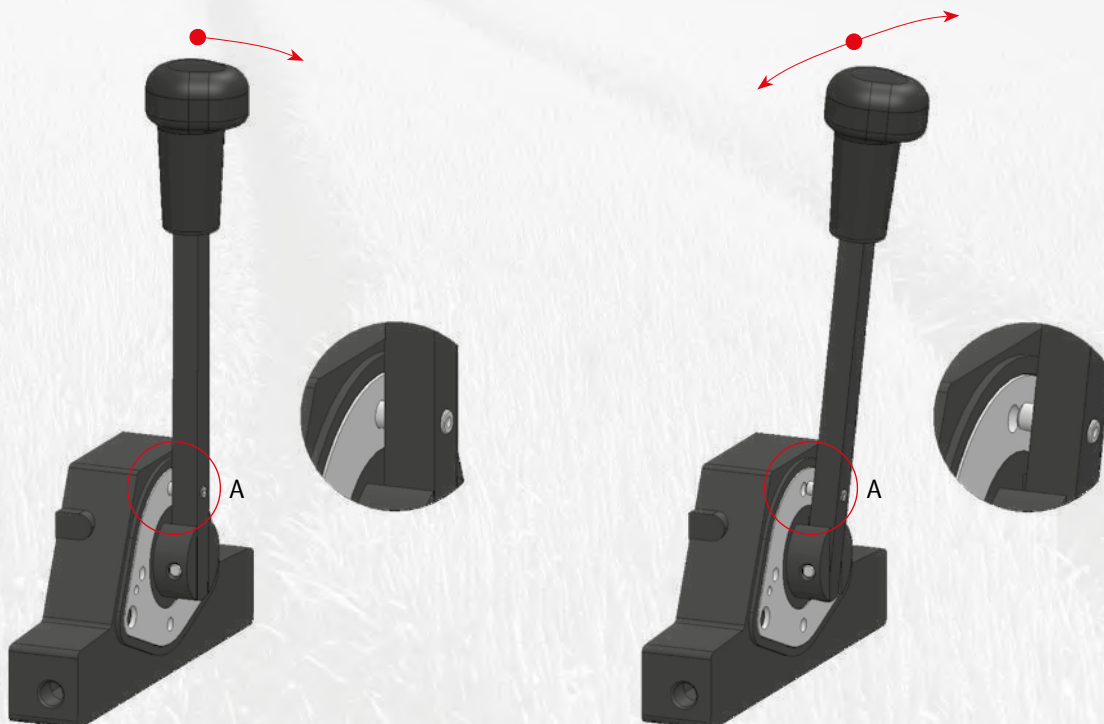

NEUTRAL DETENT MASK

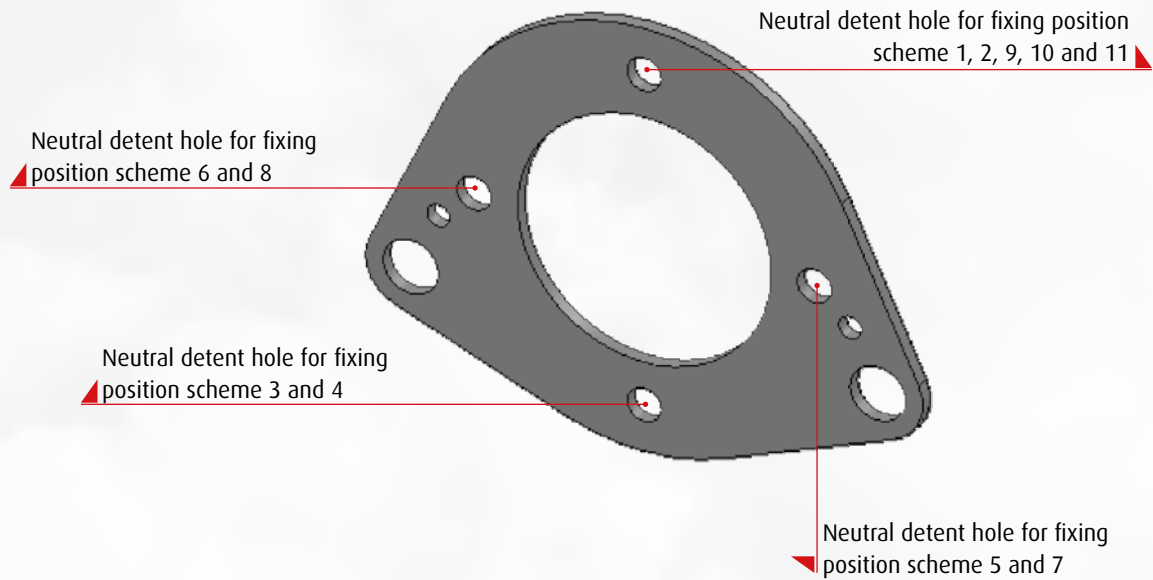

CODES

Version	How to fix	Thread M1/m1	Code
Plane	Side fixing	M10/M6	9510-11X
		M12/M6	9510-12X
		M16/M8	9510-13X
	Top fixing	M10/M6	9510-21X
		M12/M6	9510-22X
		M16/M8	9510-23X
Plane with friction	Side fixing	M10/M6	9511-11X
		M12/M6	9511-12X
		M16/M8	9511-13X
	Top fixing	M10/M6	9511-21X
		M12/M6	9511-22X
		M16/M8	9511-23X
Swinging with neutral detent	Side fixing	M10/M6	9520-11X
		M12/M6	9520-12X
		M16/M8	9520-13X
	Top fixing	M10/M6	9520-21X
		M12/M6	9520-22X
		M16/M8	9520-23X
Swinging with neutral detent and with friction	Side fixing	M10/M6	9521-11X
		M12/M6	9521-12X
		M16/M8	9521-13X
	Top fixing	M10/M6	9521-22X
		M12/M6	9521-23X
		M16/M8	9521-23X

Note:

“X” identifies the assembly of the lever and the outgoing of the cable from the lever (which can be from left or right side). There are 10 different types of assembly of the lever and outgoing of the cable from the lever. For selection, please refer to “Fixing examples” at page 43 of “Industrial Products” catalogue.

FIXING EXAMPLES

The numbers reported on each picture identify the assembly of the lever and the connection of cable onto the lever.

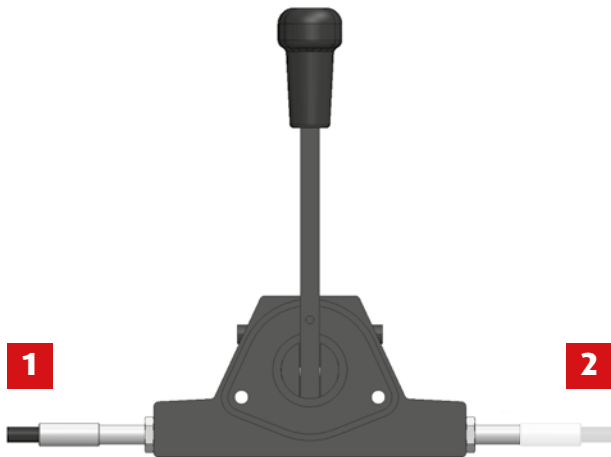

Straight lever assembly, side fixing

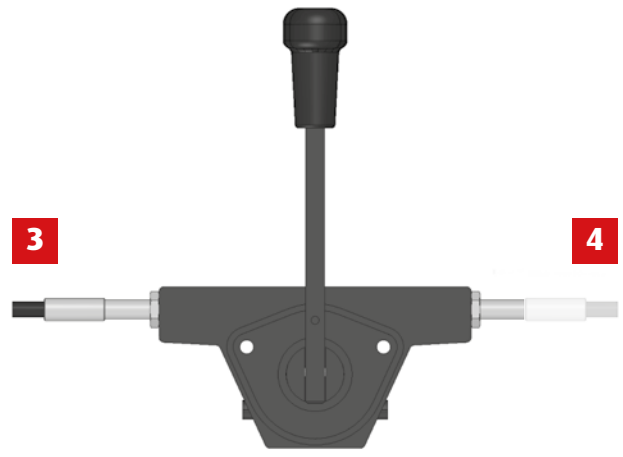

Upside-down lever assembly, side fixing

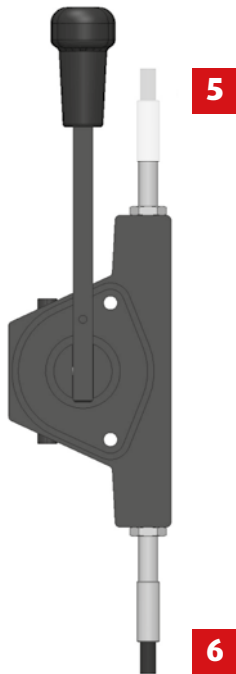

Vertical lever assembly, side fixing

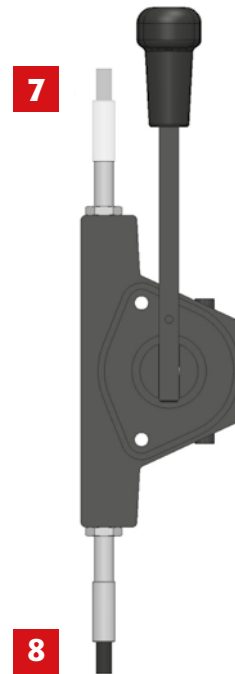

Vertical mirrored lever assembly, side fixing

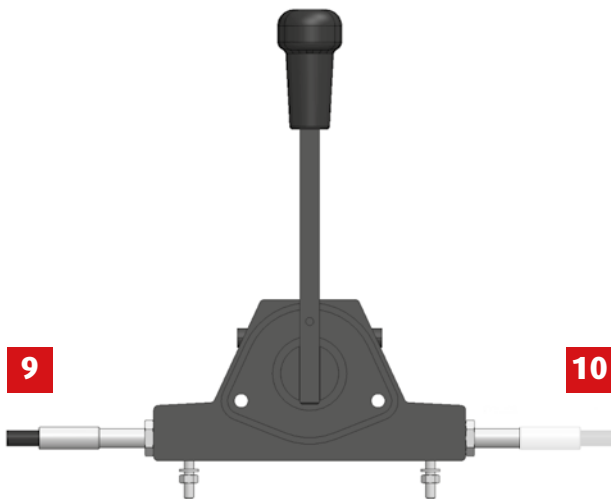

Straight lever assembly, top fixing

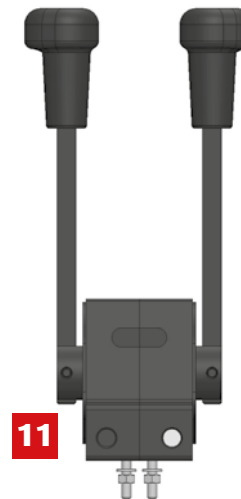

Twin lever assembly, top fixing

CABLES WHICH FIT WITH LEVER E95

Type	A	F
V4	M10/M6	M5x0.8
V5	M12/M6	M6x1
V6	M12/M6	M6x1
V7	M12/M6	M6x1
V8	M16/M8	M8x1.25
Flexball 70	M12/M6	M6x1
Flexball 95	M16/M8	M10x1.5

Notes:

- "A" specifies cable lever side thread
- "F" specifies cable engine side thread

OPTION



Reverse and neutral switch option

On swinging control lever E95 series with neutral detent are available both the neutral (N) and/or the reverse (R) switches. The N switch operates around N detent while the R switch operates as soon as neutral signal goes off, then in the full range of reverse stroke, according to the following scheme.

N AND R SWITCH SPECIFICATION

Functioning	Momentary
IP degree	IP67
Operating temp	-40°C to +85°C
Max current (resistive load)	3 A up to 30 VDC

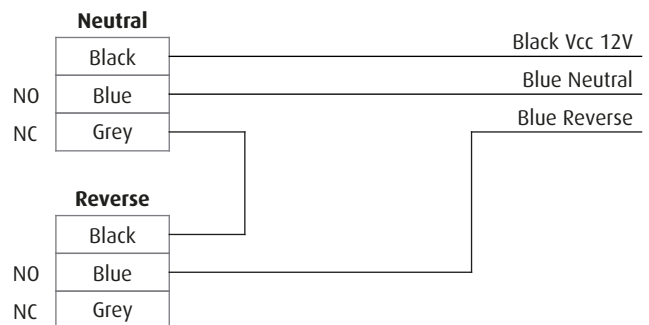
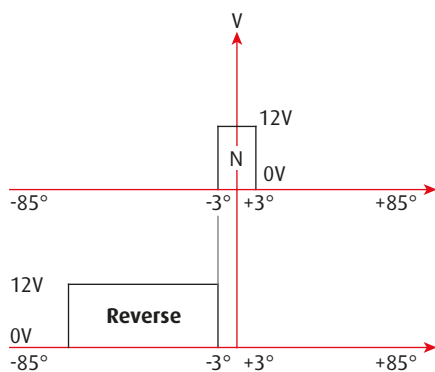

SAFETY OPTIONS

“Dead man” and “pull to unlock” are the two safety features which can be implemented, either individually or together. “Pull to unlock” is a mechanical function which obliges the operator to pull up the syringe in order to move out from Neutral position. “Dead man” is an electrical function which is active only if the switch or push button is kept pressed. The “dead man” function can be implemented on whatever version of E95 series.

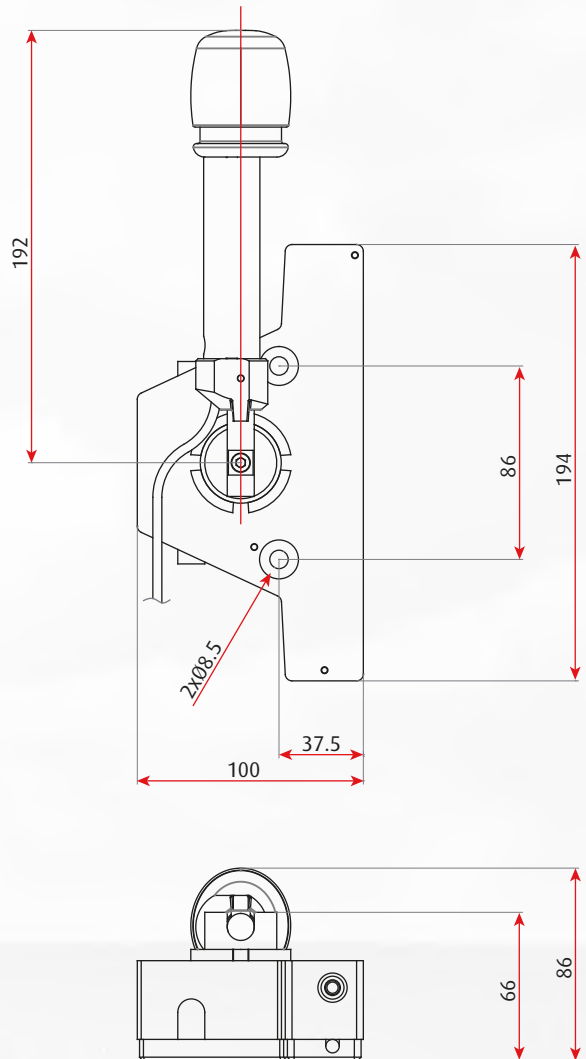
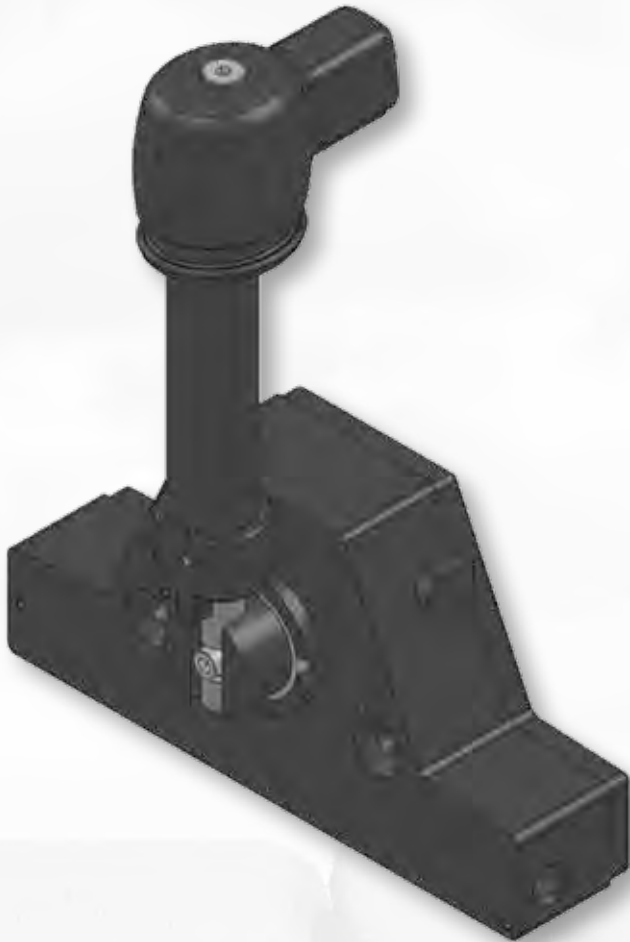

“DEAD MAN” SWITCH SPECIFICATION

Functioning	Momentary
IP degree	IP67
Operating temp	-40°C to +85°C
Max current (resistive load)	5 A up to 30VDC

Dead man

	Black	Black Vcc 12V
NO	Blue	Blue Dead man
NC	Red	Red Dead man

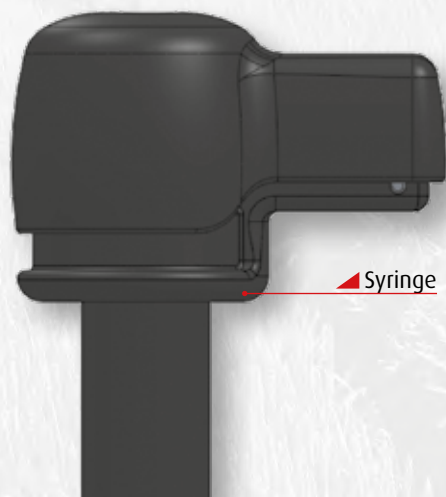

HANDLE OPTION

Both plane and swinging control E95 series can mount handle type 1705, 1725 and 1730. The handle represented in the drawing (1725) can be equipped up to 4 front switches + 1 rear "dead man" switch. For more detailed information about the handle type, switches, cabling, refer to chapter 7.

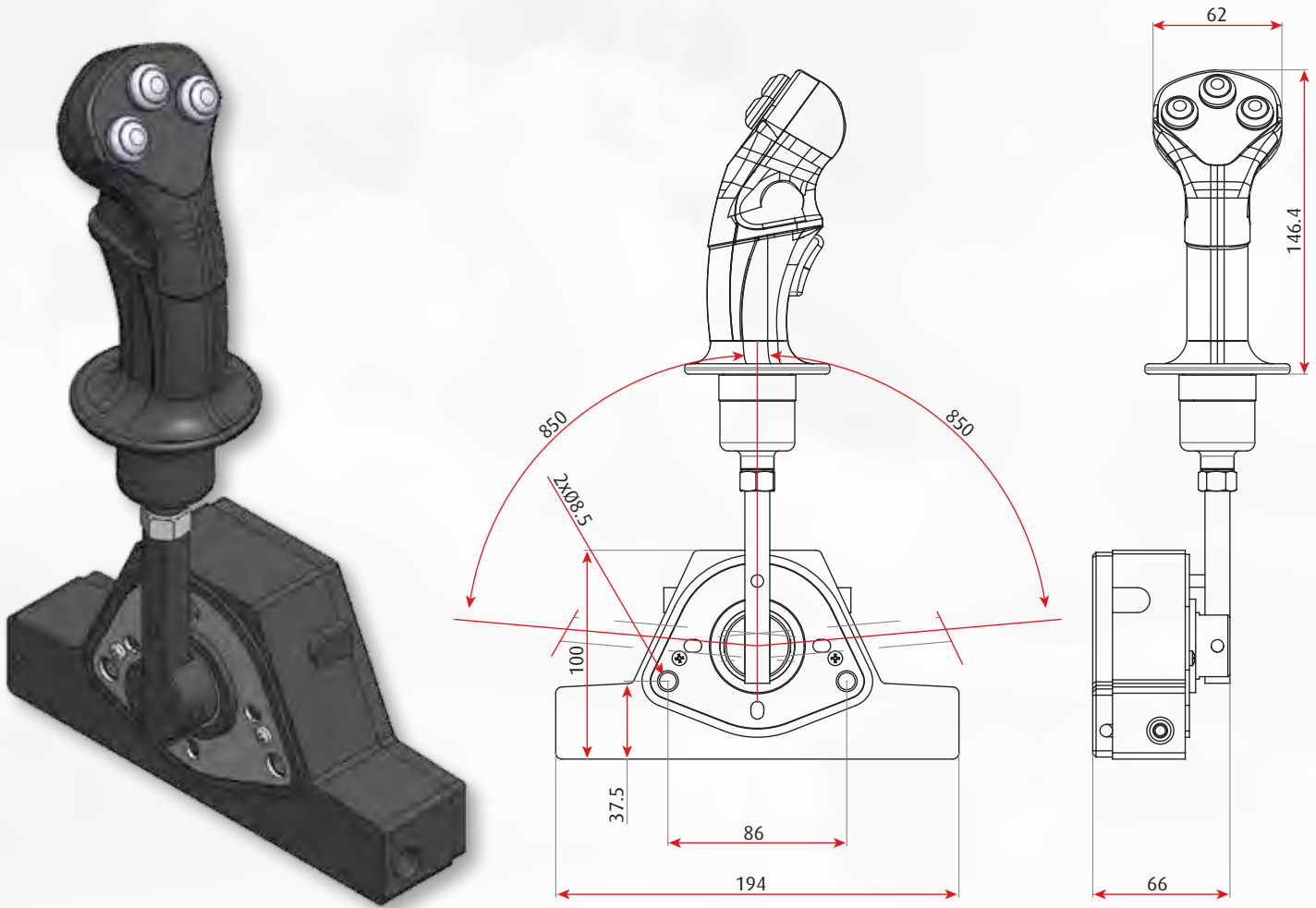

PUSH-BUTTONS POSITION AND SPECIFICATION



PUSH-BUTTONS SPECIFICATION		
Reference	1 - 2 - 3 - 4 - 5	R
Operation	Momentary	Momentary
IP degree	IP67	IP67
Operating temp	-30°C to 85°C	-40°C to +85°C
Max current (resistive load)	200 mA 50VDC	3 A up to 30 VDC

CODING SYSTEM

The following suffix must be added to the basic code of the standard lever E95 (page 42, at previous page).

TYPE OF SIGNAL	HANDLE	PUSH BUTTONS		SPECIAL CUSTOM PROJECTS	
S	K	P1	P2	X	X

S defines the type and combination of signals:

S = 0 without any switch (standard version)

S = 1 Neutral

S = 2 Reverse

S = 3 Neutral + Reverse

K defines the type of handle
(for complete description of handles refer to Chapter 7 of the Industrial Catalogue):

K = 0 standard (no switches)

K = 1 "pull to unlock"

K = 2 "dead man"

K = 3 "pull to unlock" + "dead man"

K = 4 ergonomic handle

P1 **P2** define the number, type and position of switches:

P1 = number of push buttons on the front

P2 = number of push buttons on the rear

In case of Multifunction handle, tick in the below table the position of the switches needed according to the drawing at previous page.

1	2	3	4	5	R

X **X** A numbering system from 0 to 99 is used to define special projects, cable length, number of poles, type of connector, etc.

103

Small/medium size

Rack and pinion control lever series 103 is used in several applications in the industrial sector to perform regulation and force transmission as well

Quite small, aluminium made, this lever is very suitable for wall mounting applications. It can be equipped with several types of knobs and levers, with or without central locking. Friction is available as an option. Lever stroke range is between 50 and 100 mm.



VERSION WITH LOCKING DEVICE

The locking lever (metal colour) allows to lock or unlock the manoeuvring lever (black colour).



DIMENSIONS

DIMENSIONS CHANGE IN FUNCTION OF THE LEVER'S STROKE			
Stroke	A	B	C
50	60	93	153
75	85	118	203
100	110	143	253

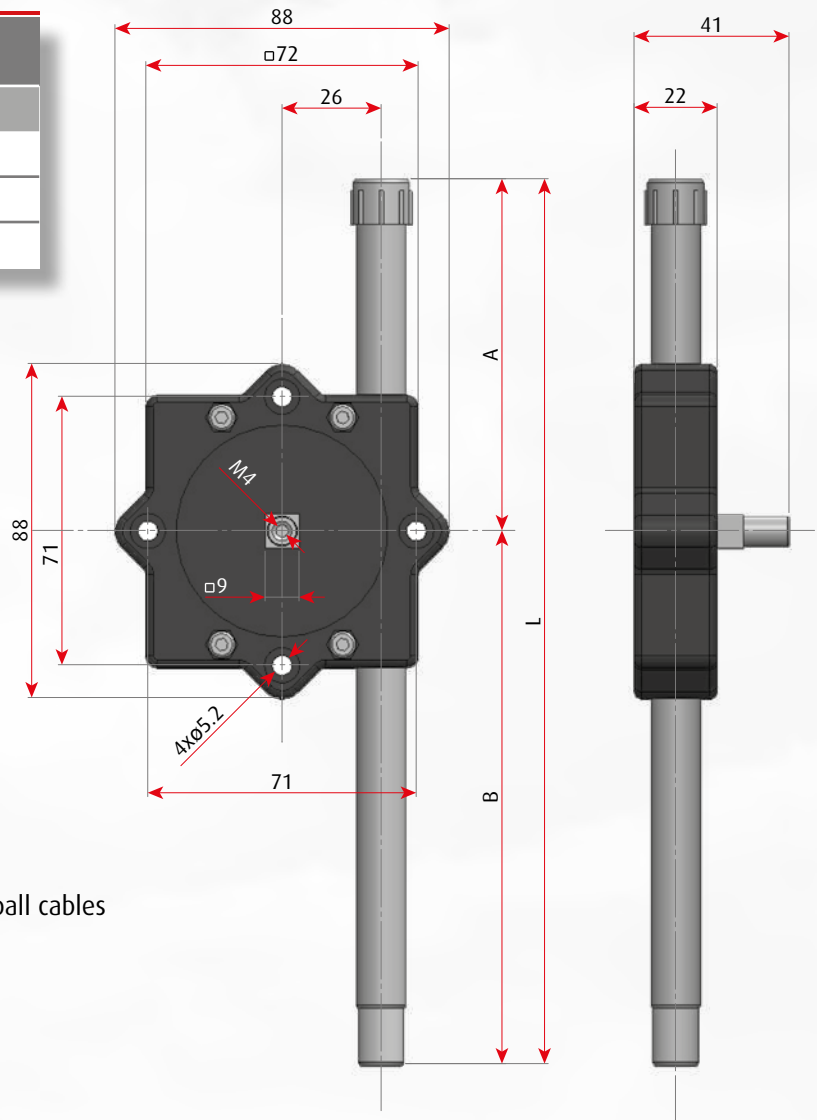

SPECIFICATION

- It is possible to connect either push-pull or Flexball cables
- Primitive diameter: 48 mm
- Number of teeth: 48
- Module: 1 mm

HANDLE TYPES

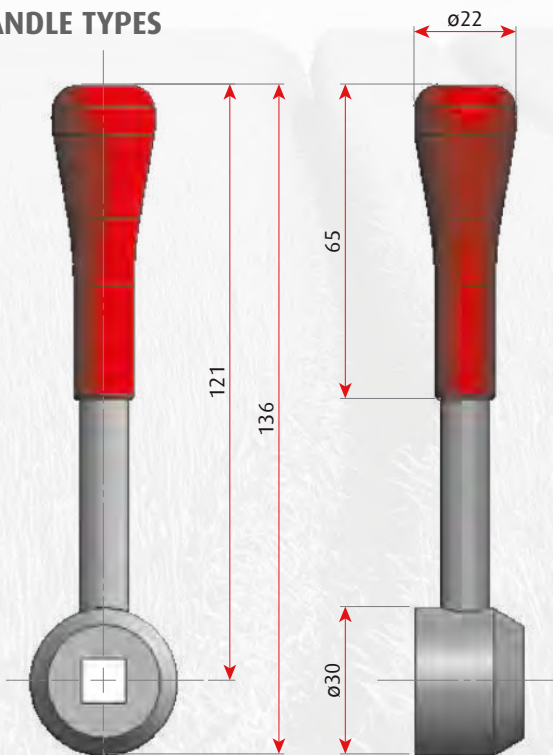

▲ Lever with orange rubber knob

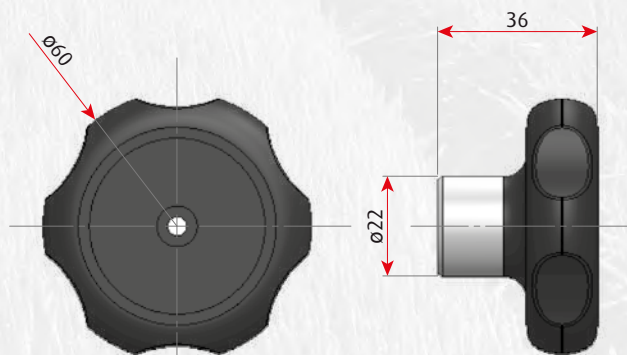

▲ Rounded plastic knob with die casted insert

CODES

Stroke	Side of handle	Locking device	Rack inside the pipe	Type of handle	Code
50 (1) 75 (2) 100 (3)	Left	With	With	Black Rounded Knob	0103-(1)(2)(3)1221
				Orange Knob	0103-(1)(2)(3)1222
				Black Rounded Knob	0103-(1)(2)(3)1223
		Without	With	Black Rounded Knob	0103-(1)(2)(3)1021
				Orange Knob	0103-(1)(2)(3)1022
				Black Rounded Knob	0103-(1)(2)(3)1023
	Right	With	With	Black Rounded Knob	0103-(1)(2)(3)2221
				Orange Knob	0103-(1)(2)(3)2222
				Black Rounded Knob	0103-(1)(2)(3)2223
		Without	With	Black Rounded Knob	0103-(1)(2)(3)2021
				Orange Knob	0103-(1)(2)(3)2022
				Black Rounded Knob	0103-(1)(2)(3)2023

Note:

To identify the correct code, chose (1), (2) or (3) in relation to the cable's stroke.



▲ Lever with left side mounting handle

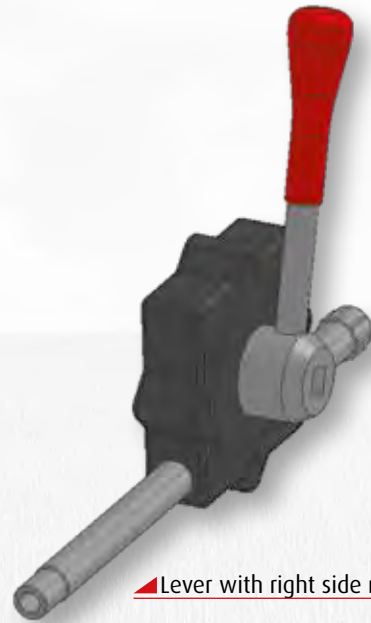

▲ Lever with right side mounting handle

CABLES WHICH FIT WITH LEVER 103

Type	A	F
Flexball 70	Rack with external connection to the pipe	M6x1
V4	Rack with external connection to the pipe	M5x0.8
007	Rack with external connection to the pipe	M6x1

Notes:

- "A" specifies cable lever side
 - "F" specifies cable engine side
 - "mmmm" is the length of the cable in mm
- Cable's engine side can be configured with any shape as shown at page 16.

561

Big size

Extremely flexible, it can be mounted side by side offering the possibility to create a system of several levers in a limited amount of space. It is available in different versions, either with knob or handle and can be customized according to any specification



DIMENSIONS

Unit with standard lever.

DIMENSIONS CHANGE IN FUNCTION OF THE LEVER'S STROKE			
Stroke	A	B	C
75	60	93	153
100	85	118	203
150	110	143	253

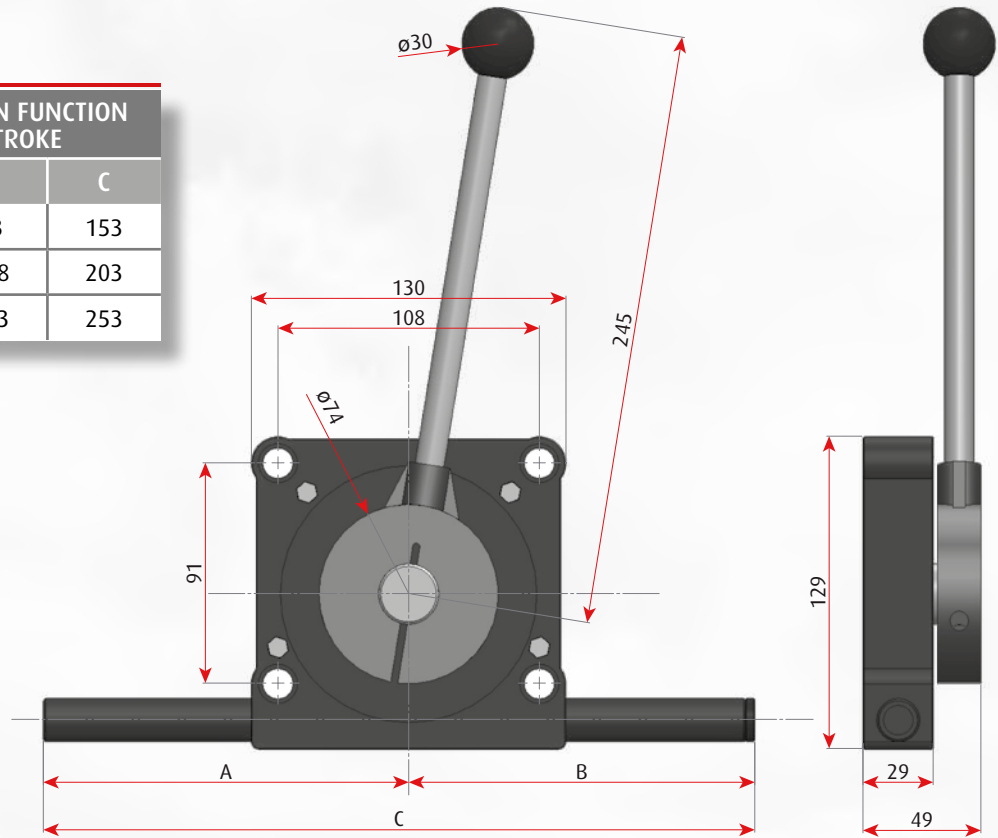

Unit with aluminum handle (black or red).

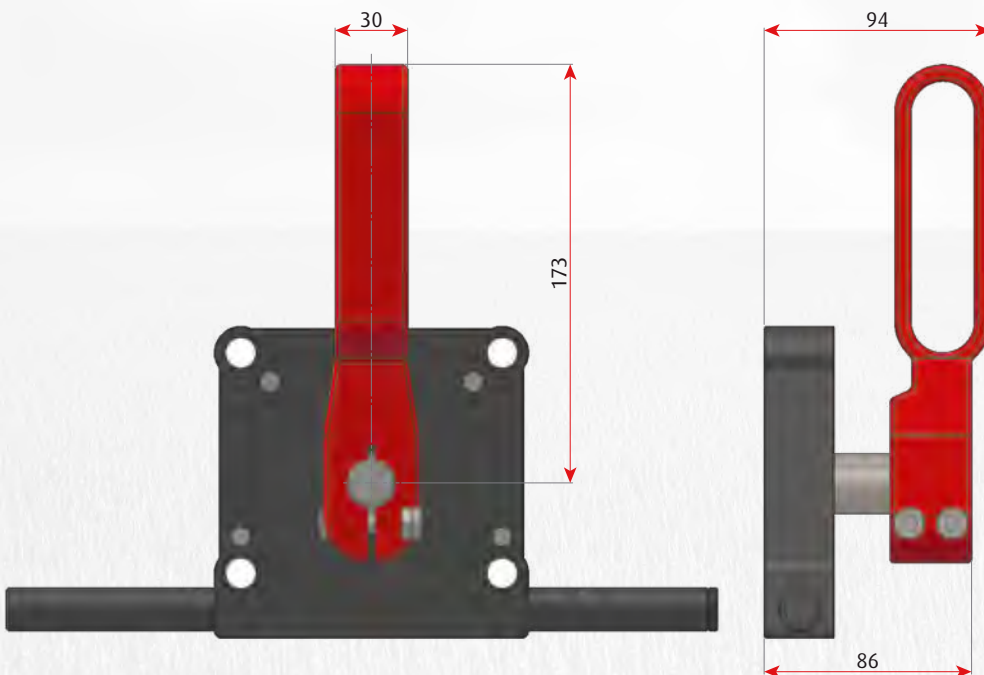

For the other dimensions of the control lever, please refer to the drawing above.

SPECIFICATION

- It is possible to connect either push-pull or Flexball cables
- Primitive diameter: 72 mm
- Number of teeth: 48
- Module: 1.5 mm

CODES

Stroke	Side of the handle	Rack inside the pipe	Code
75	Left	With	0561-211
		Without	0561-210
	Right	With	0561-221
		Without	0561-220
100	Left	With	0561-311
		Without	0561-310
	Right	With	0561-321
		Without	0561-320
150	Left	With	0561-411
		Without	0561-410
	Right	With	0561-421
		Without	0561-420

* Cable outgoing side

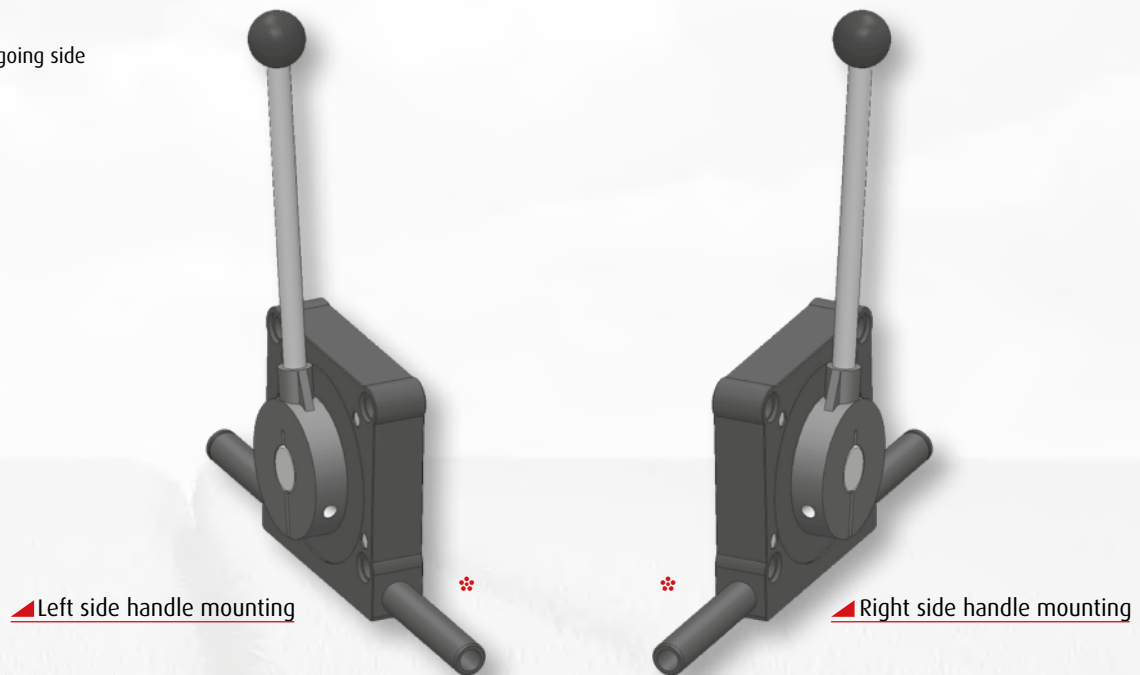

CABLES WHICH FIT WITH LEVER 561

Type	A	F
07, 07E	Rack with external connection to the pipe	M6X1
V6	Rack with external connection to the pipe	M6X1
V7	Rack with external connection to the pipe	M6X1
V8	Rack with external connection to the pipe	M8X1.25
Flexball 70	Rack with external connection to the pipe	M6X1
Flexball 95	Rack with external connection to the pipe	M10X1.5

Notes:

- "A" cable lever side
 - "F" specifies cable engine side
- Cable's engine side can be configured with any shape as shown at page 16 of "Industrial Products" catalogue.

901

Big size

This series of control levers, with robust and essential design, is based on a rack and pinion mechanism and it is indicated for heavy duty applications

Levers 901 are suitable to command winches, gearboxes, big and small cranes, concrete mixers.

Standard configurations are: single lever (one cable can be connected), single lever + locking device, two levers (two cables can be connected) + locking device.

Depending on the pipe mounted on the lever, strokes available are: 50, 70, 100, 125, and 150 mm.



LEVER 901.1

It is a single lever for the command of one cable, available with or without neutral detent.

Stroke	A	B	C
50	90	110	200
70	110	130	240
100	140	152	292
125	168	177	342
150	190	202	392

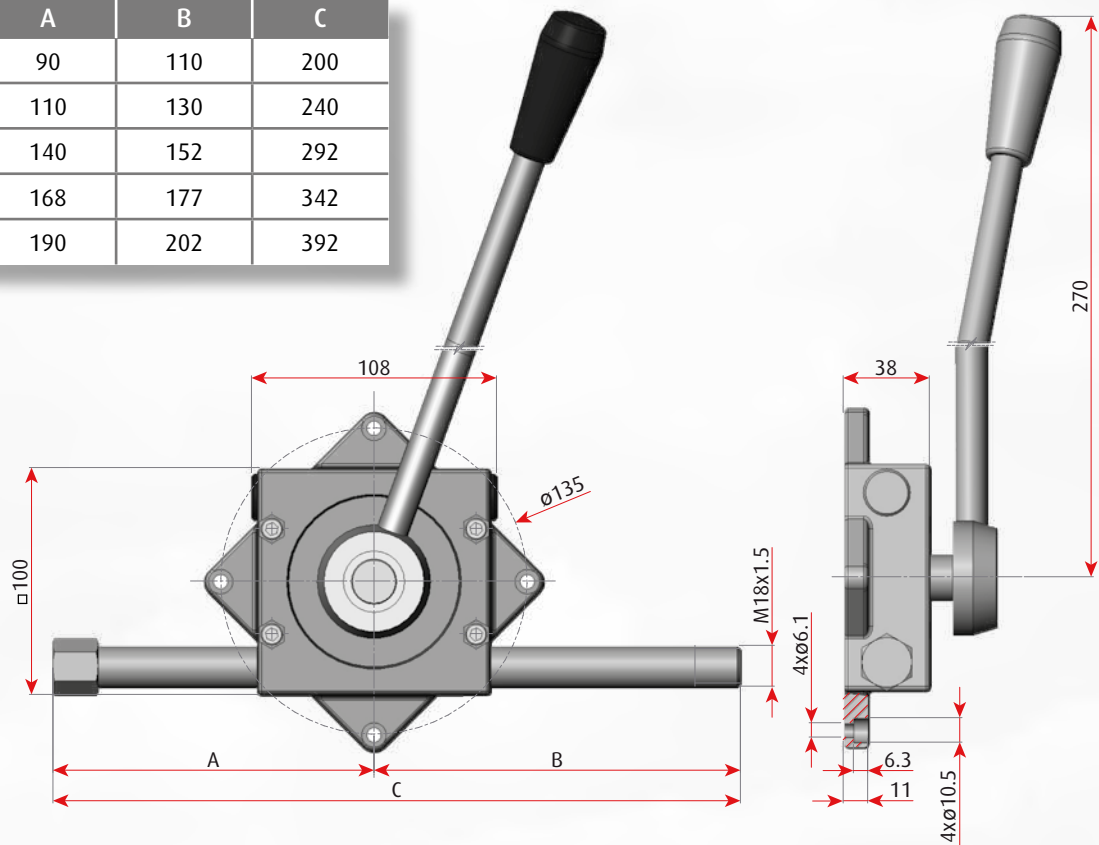

LEVER 901.2

It is a single lever for the command of one cable, with the locking function. The locking lever (metal colour) allows to lock or unlock the manoeuvring lever (black colour). It is available with or without neutral detent.

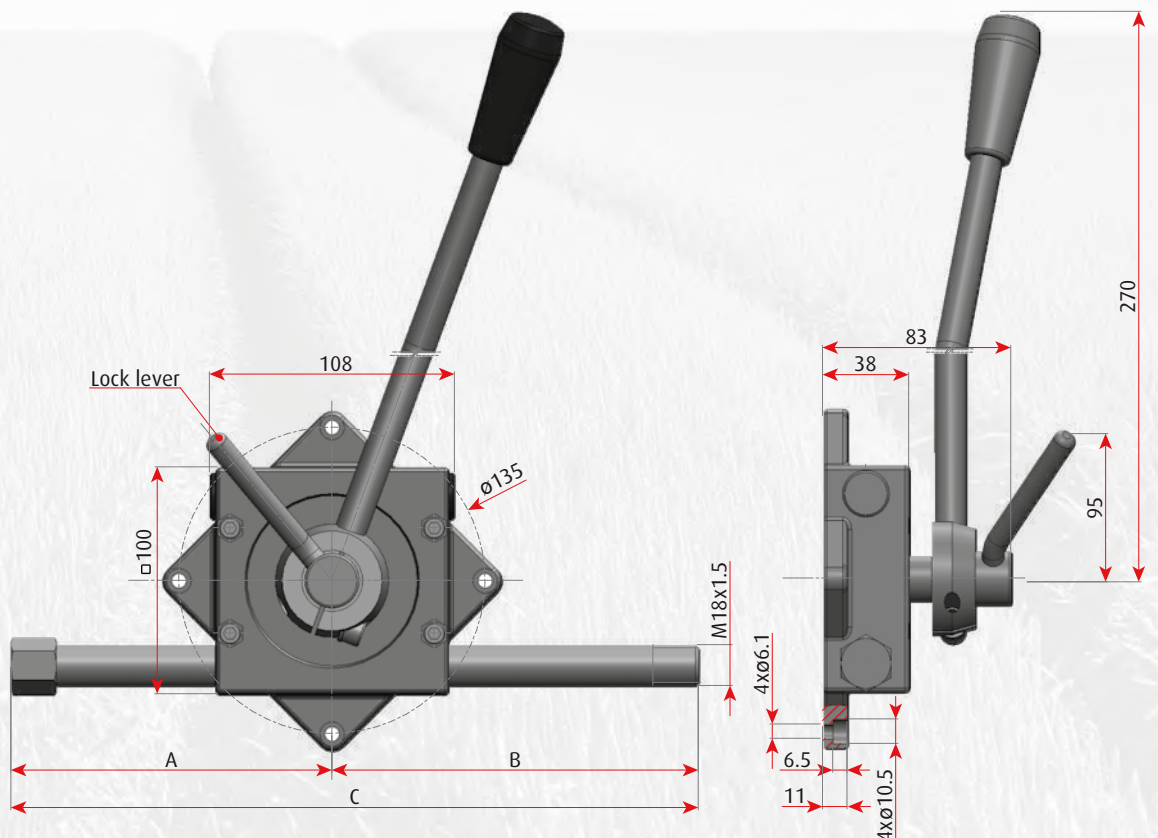

LEVER 901.3

With this kind of lever it is possible to command two push-pull cables. Typically it is used to command throttle and machine's motion. The locking lever (metal colour) allows to lock or unlock the manoeuvring levers (black colour). It is equipped with locking device and it is available with or without neutral detent.

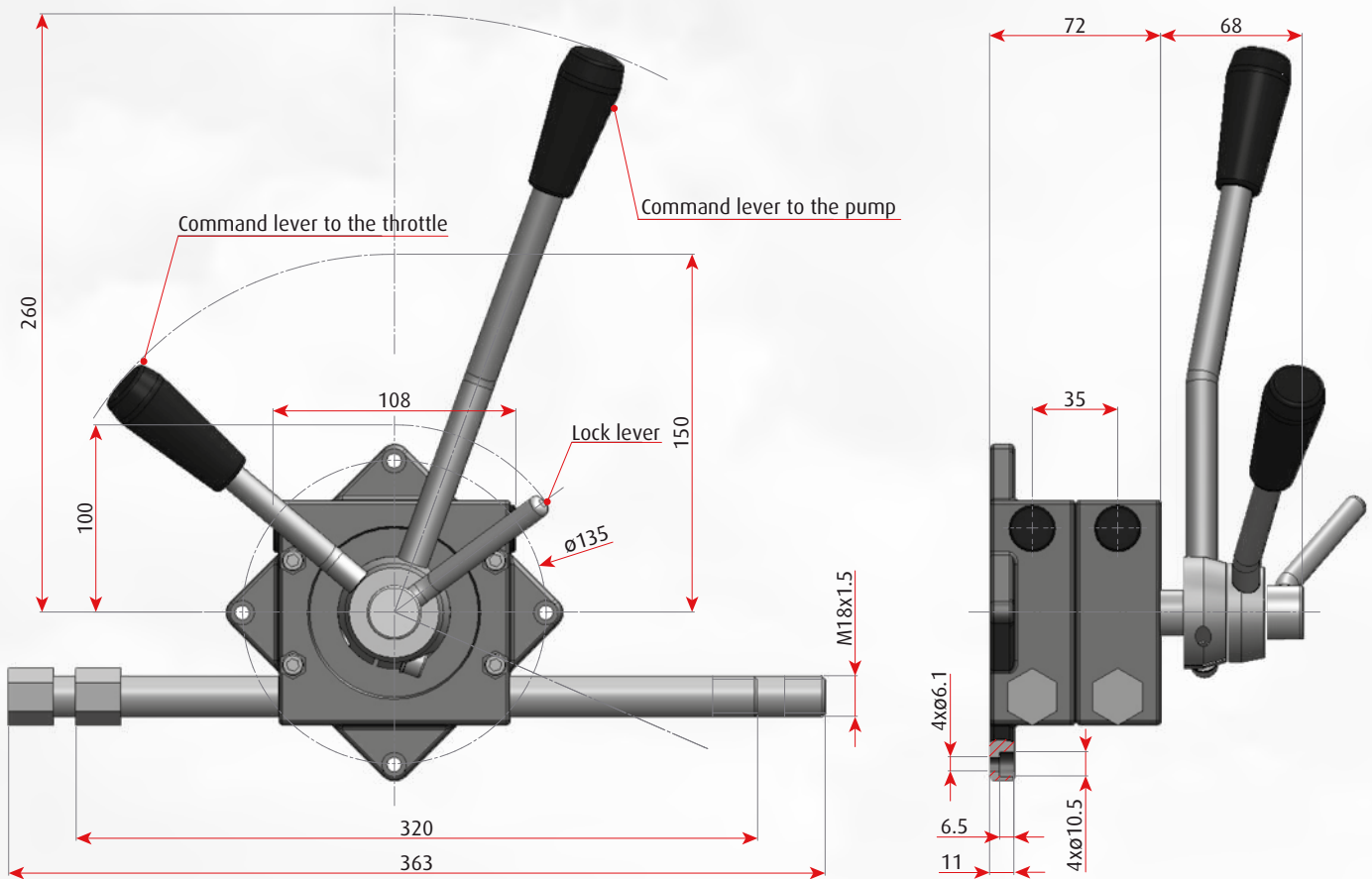

SPECIFICATION

- It is possible to connect either push-pull or Flexball cables
- Primitive diameter: 72 mm
- Number of teeth: 48
- Module: 1.5 mm

ALUMINIUM HANDLE OPTION

As an alternative to the standard knob, it is available an aluminium handle either red or black.

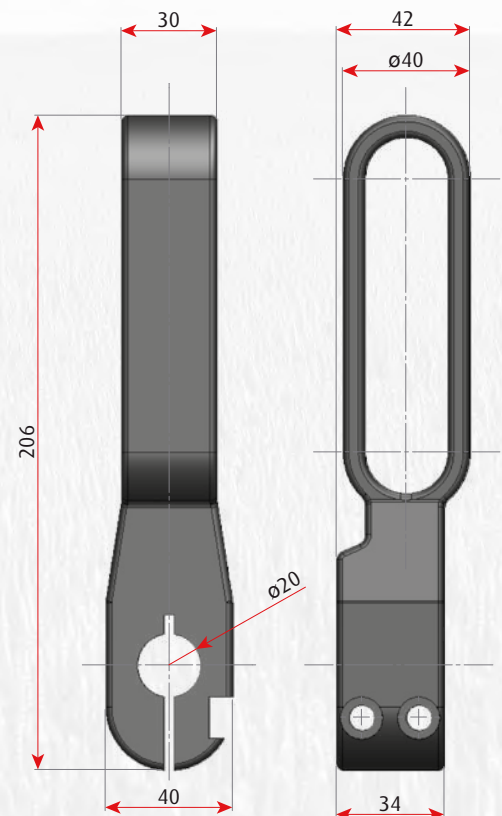
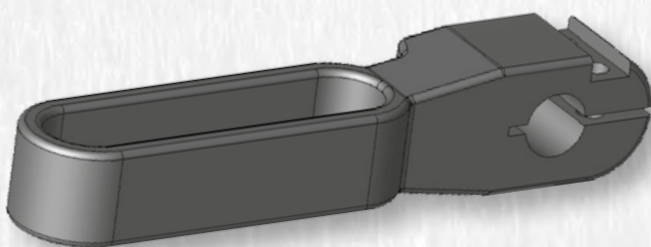

CONFIGURATION SCHEMES

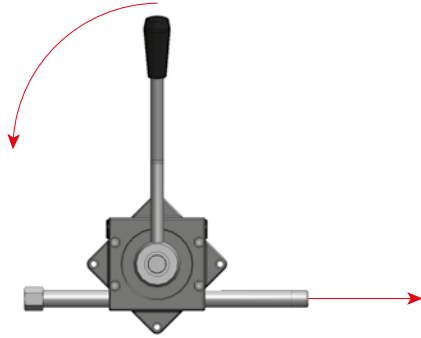

- System with one lever, one command station, one push-pull cable

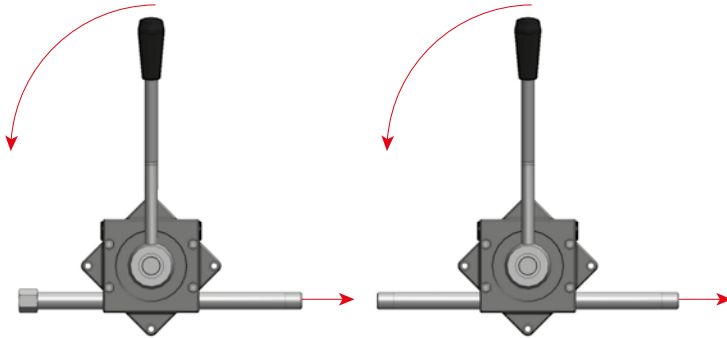

- System with two levers, two command stations and two push-pull cables
- Moving the lever of one command station, it moves also the lever of the second command station

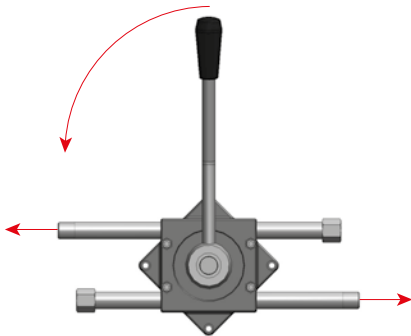

- System with one lever, one command station and two push-pull cables
- Moving the lever of the command station, both push-pull cables move together but in opposite directions

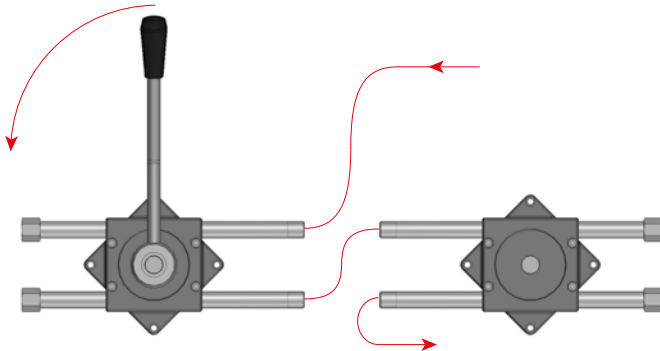

- System with one command station lever, one shifting lever and two push-pull cables
- Activating the command lever, movement is transmitted to the shifting lever which activates the device where is mounted the shifting lever

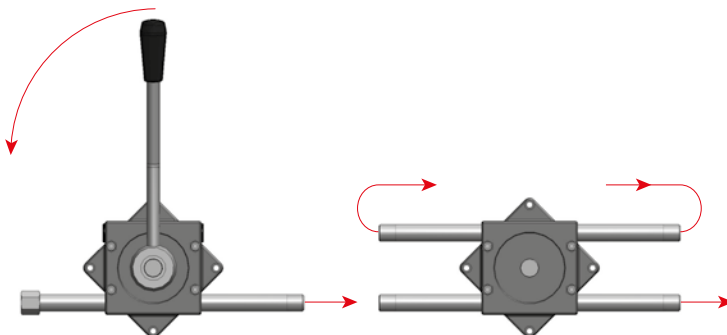

- System with one command lever, one shifting lever and two push pull cables
- Moving the command lever, the cable transmits the movement to the shifting lever which inverts the movement on the second cable connected to the shifting lever

LEVER 901 WITH ONE PIPE AND ONE OUTPUT

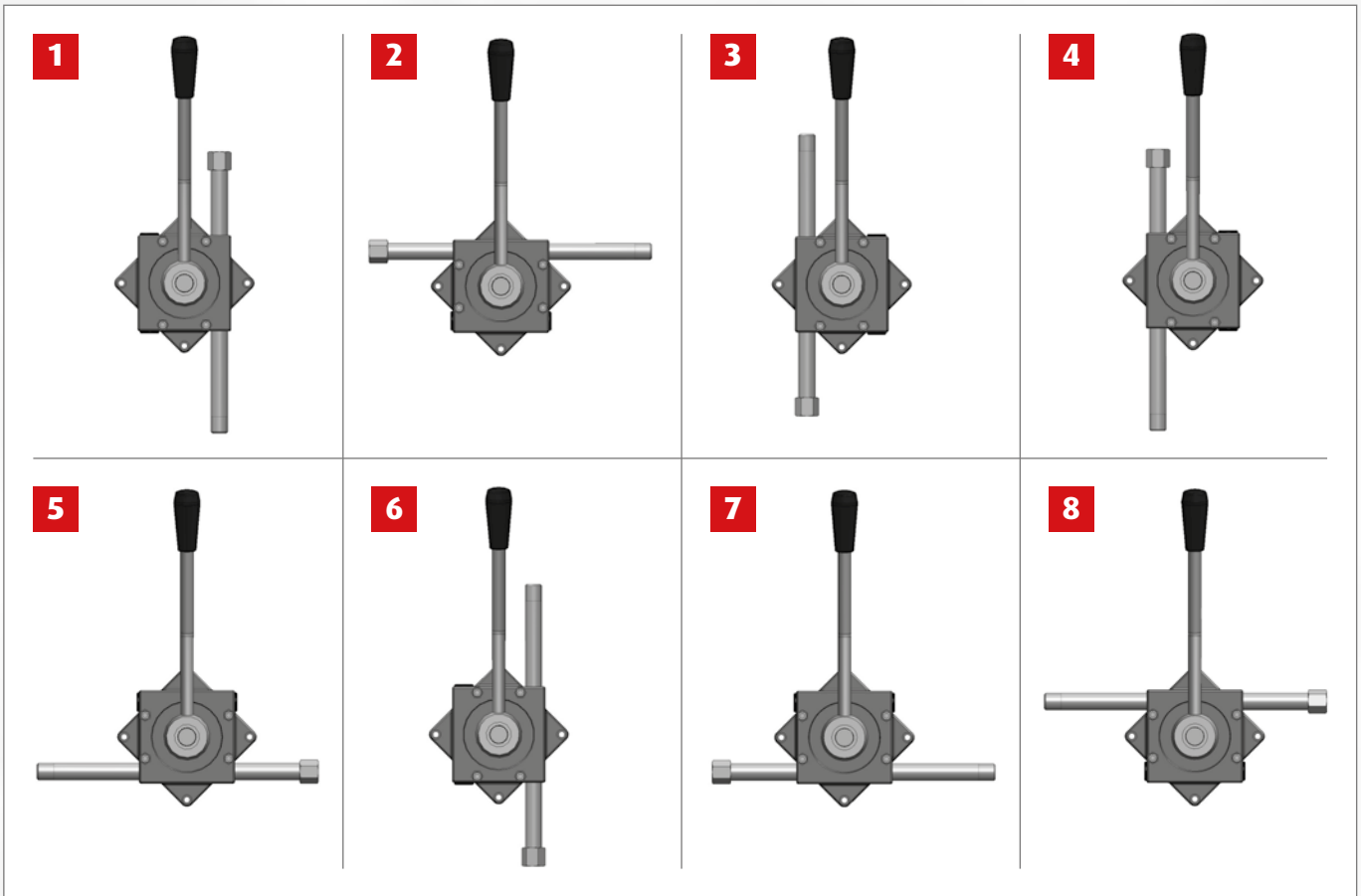

LEVER 901 WITH ONE PIPE AND TWO OUTPUTS

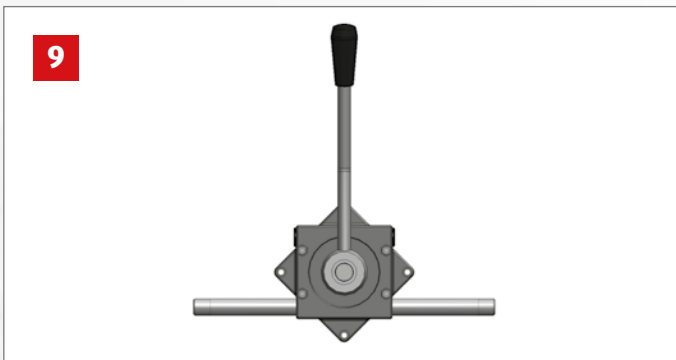

LEVER 901 WITH TWO PIPES AND TWO OUTPUTS

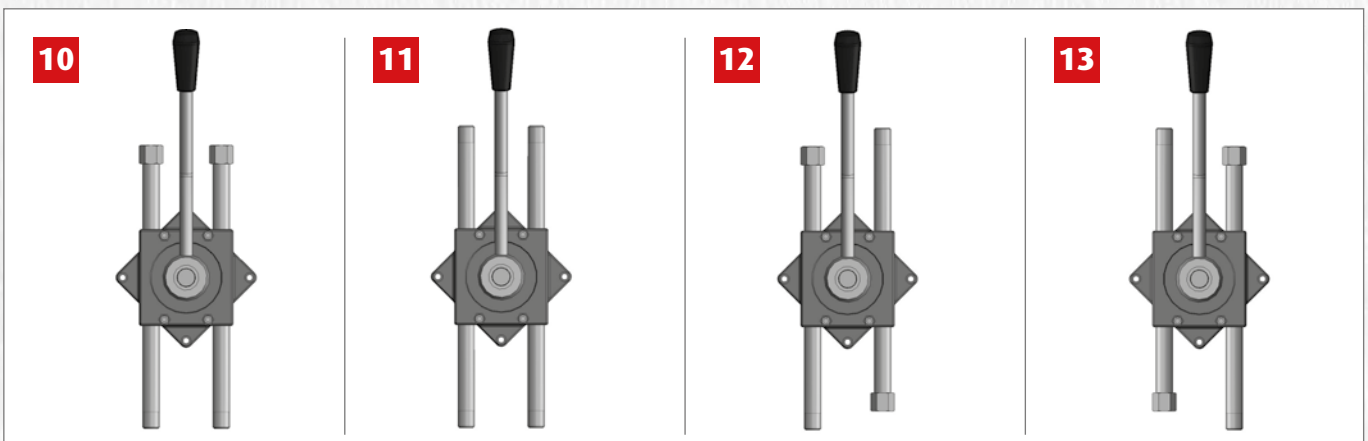

CODES

Version	Stroke	2nd stroke (only for version 901.3)	Mounting	Neutral detent	Code
901.1	50		X	No	9011-2X0
				Yes	9011-2X1
	70		X	No	9011-3X0
				Yes	9011-3X1
	100		X	No	9011-4X0
				Yes	9011-4X1
	125		X	No	9011-5X0
				Yes	9011-5X1
	150		X	No	9011-6X0
				Yes	9011-6X1
901.2	50		X	No	9012-2X0
				Yes	9012-2X1
	70		X	No	9012-3X0
				Yes	9012-3X1
	100		X	No	9012-4X0
				Yes	9012-4X1
	125		X	No	9012-5X0
				Yes	9012-5X1
	150		X	No	9012-6X0
				Yes	9012-6X1
901.3	50	50	X	No	9013-22X0
				Yes	9013-22X1
	70	70	X	No	9013-33X0
				Yes	9013-33X1
	100	100	X	No	9013-44X0
				Yes	9013-44X1
	125	125	X	No	9013-55X0
				Yes	9013-55X1
	150	150	X	No	9013-66X0
				Yes	9013-66X1

Notes:

“X” is a two digit variable which identifies the type of mounting of the lever. It ranges from 01 to 13 as specified at page 55 of “Industrial Products” catalogue.

Usually Lever 901 is provided without the rack inside. The rack is delivered only on demand.

CABLES WHICH FIT WITH LEVER 901

Type	A	F
07, 07E	Rack with external connection to the pipe	M6x1
V6	Rack with external connection to the pipe	M6x1
V7	Rack with external connection to the pipe	M6x1
V8	Rack with external connection to the pipe	M8x1.25
Flexball 70	Rack with external connection to the pipe	M6x1
Flexball 95	Rack with external connection to the pipe	M10x1.5
Flexball 125	Rack with external connection to the pipe	M12x1.5



▲ Example of connection of lever 901 to a Flexball cable



▲ Example of connection of lever 901 to a push-pull cable

920

Big size

▼ It is a single rack and pinion lever with locking device function

It is very robust and it can be used in heavy duty applications with high load transmissions. It is therefore suitable on concrete mixers and vibrating machines. Only one push-pull cable can be connected.

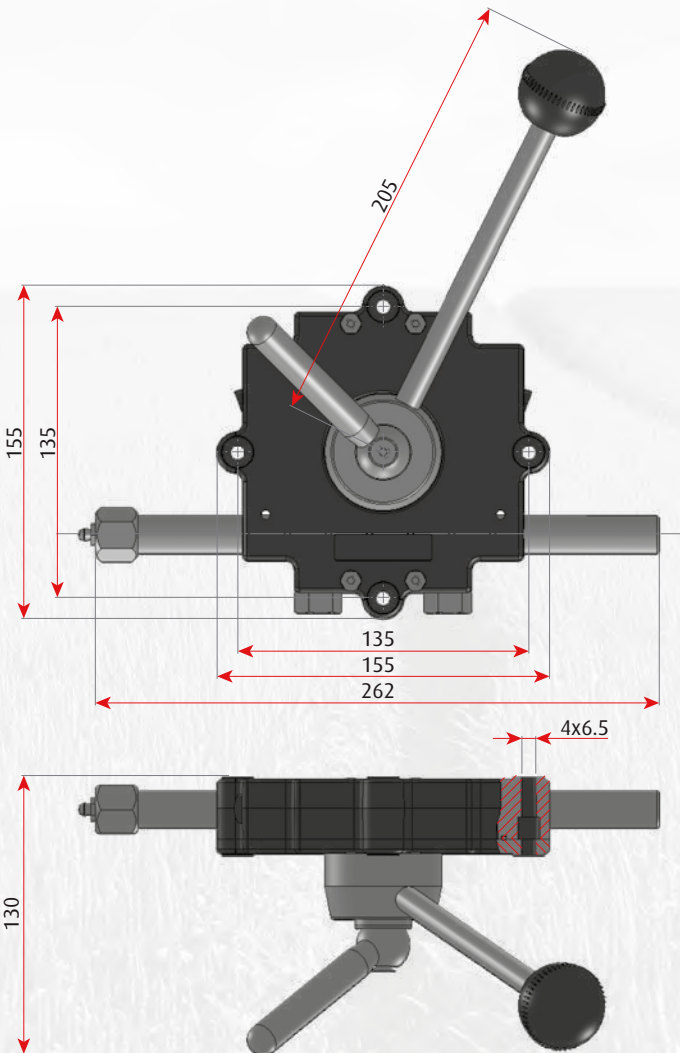
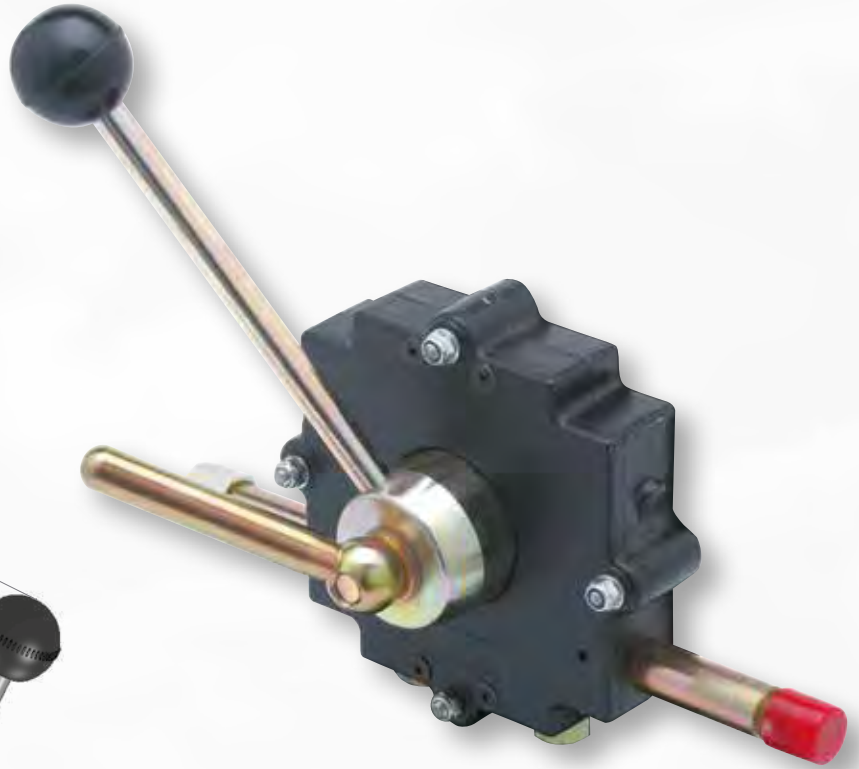

CODING SYSTEM

BASIC CODE	STROKE	CUSTOMIZATION
920	.AA	.XX

AA defines the cable strokes according to the following codification:

- 00 = stroke 75
- 01 = stroke 100
- 02 = stroke 125
- 03 = stroke 150
- 04 = stroke 200

XX customization

930 Big size

It is a double rack and pinion lever with locking device function. It is a very robust lever used in heavy duty applications with high load transmissions. It is therefore suitable on concrete mixers and vibrating machines. Two push-pull cables can be connected.

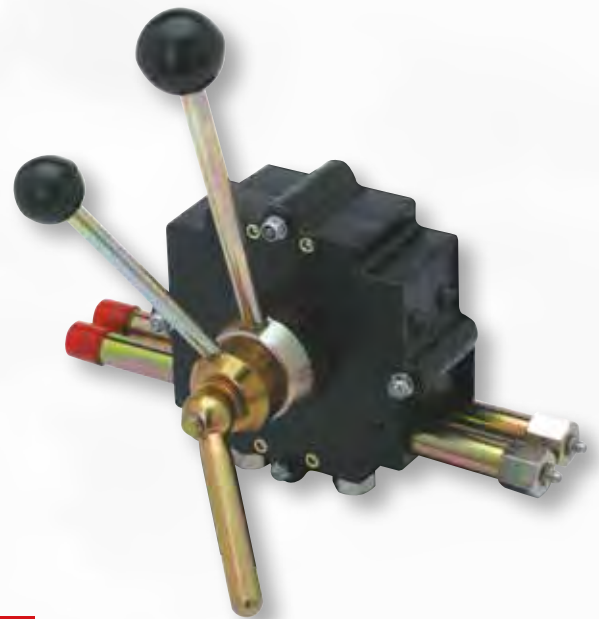
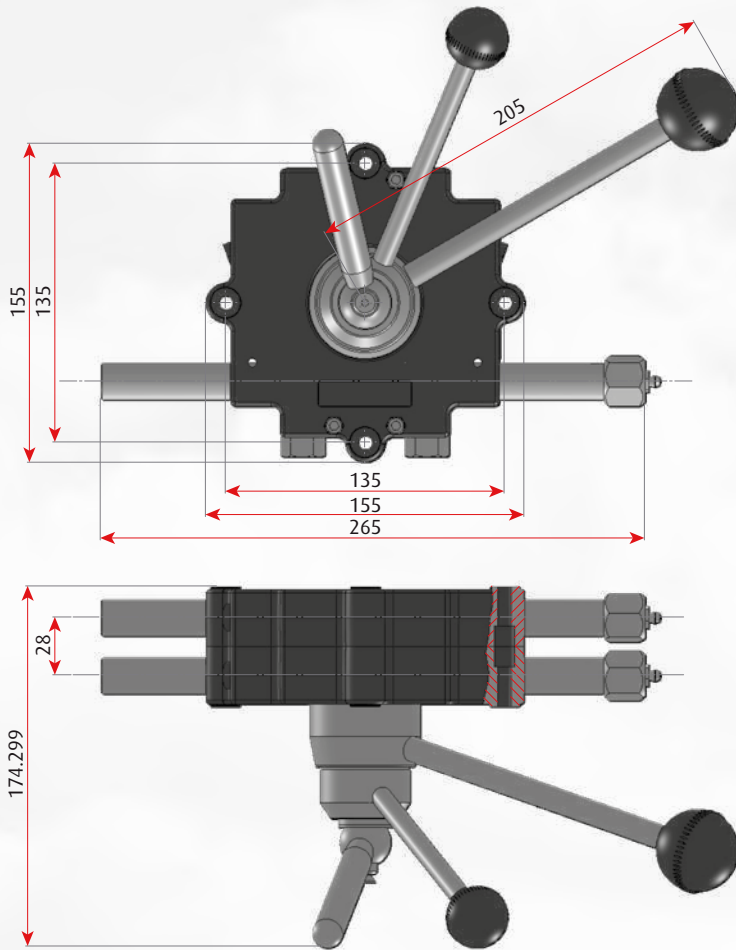

CODING SYSTEM

BASIC CODE	STROKE CABLE BRACKET SIDE	STROKE CABLE LEVER SIDE	CUSTOMIZATION
920	.AA	.BB	.XX

AA defines the cable strokes of cable bracket side:

- 00 = stroke 75
- 01 = stroke 100
- 02 = stroke 125
- 03 = stroke 150
- 04 = stroke 200

BB defines the cable strokes of cable lever side:

- 00 = stroke 75
- 01 = stroke 100
- 02 = stroke 125
- 03 = stroke 150
- 04 = stroke 200

XX customization

CABLES WHICH FIT WITH LEVERS 920 & 930

Type	A	F
07, 07E	Rack with external connection to the pipe	M6x1
V6	Rack with external connection to the pipe	M6x1
V7	Rack with external connection to the pipe	M6x1
V8	Rack with external connection to the pipe	M8x1.25
Flexball 70	Rack with external connection to the pipe	M6x1
Flexball 95	Rack with external connection to the pipe	M10x1.5

Note: Cable's engine side can be configured with any shape as shown at page 16 of "Industrial Products" catalogue.

1068

Multi function levers

Series of control levers with robust and essential design based on rack and pinion mechanism



This lever, which is indicated for heavy duty applications and can be customize for specific applications, is used to command the hydraulic pump for the motion of the machine. Neutral, forward and reverse positions can be electrically signalled via micro-switch or via inductive sensor.

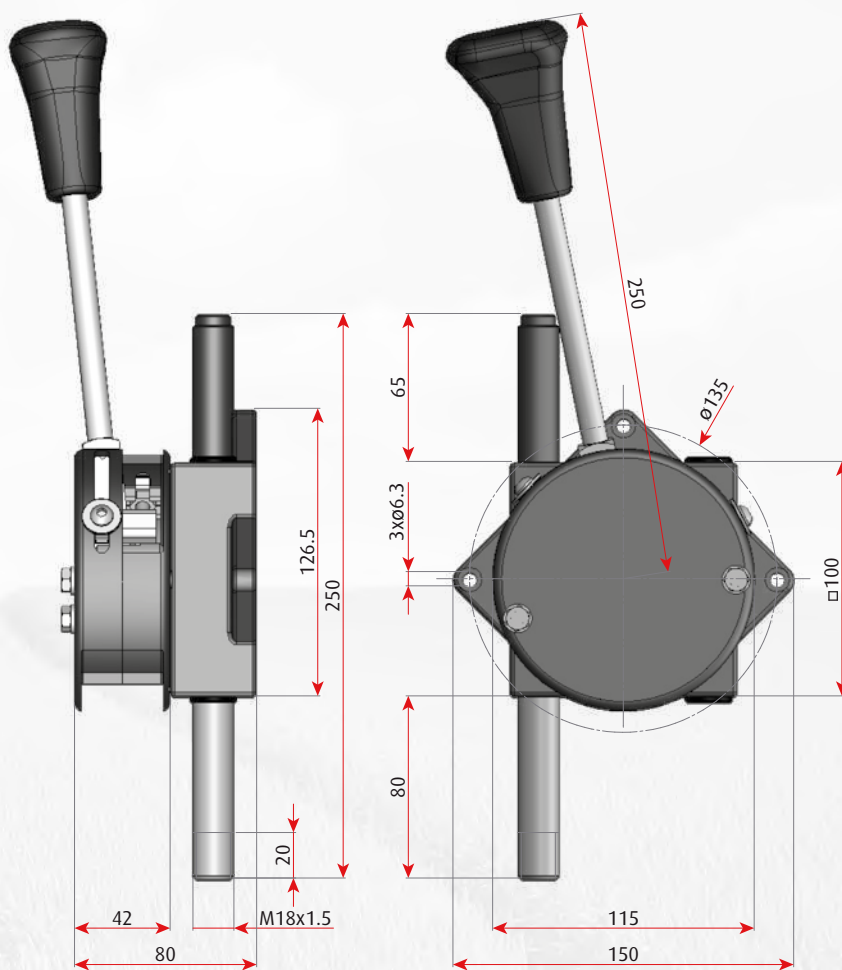

SPECIFICATION

- Maximum working load (on cable): 800 N
- Maximum stroke: 75 mm
- Lever ratio: 6.7:1
- Available with different handles, lever switches and bush-buttons
- Electrical signalling of the lever's position via micro-switch

CABLES WHICH FIT WITH LEVER 1068

Type	A	F
07, 07E	Rack with external connection to the pipe	M6x1
V6	Rack with external connection to the pipe	M6x1
V7	Rack with external connection to the pipe	M6x1
V8	Rack with external connection to the pipe	M8x1.25
Flexball 70	Rack with external connection to the pipe	M6x1
Flexball 95	Rack with external connection to the pipe	M10x1.5

Notes:

Cable's engine side can be configured with any shape as shown at page 16 of "Industrial Products" catalogue.

ETC

Multifunction levers

ETC are robust and versatile levers which can combine multi functions for:

- throttle control
- command of hydrostatic pump
- gear shifter
- speed inversion

ETC is available in dozens of customizations, such as: single or double configuration, with or without friction. ETC can be plane or swinging. Its lever's movement is guided through a slot, whose paths is specific per each application. More than 25 mask paths are available as standard, furthermore the path can be designed according on specific customer's request.



◀ ETC single function

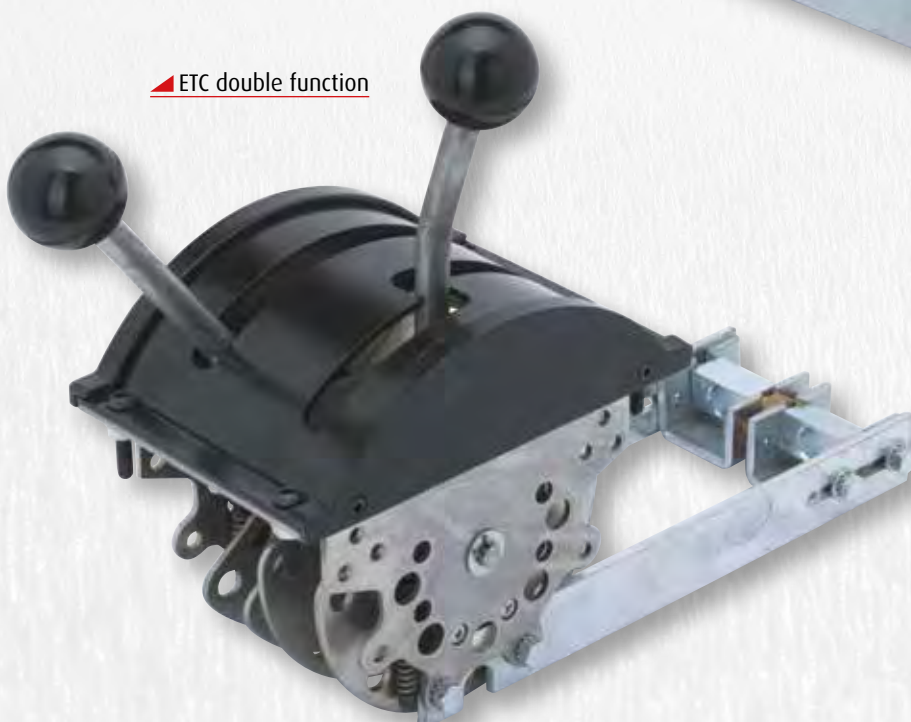

◀ ETC double function

DIMENSIONS

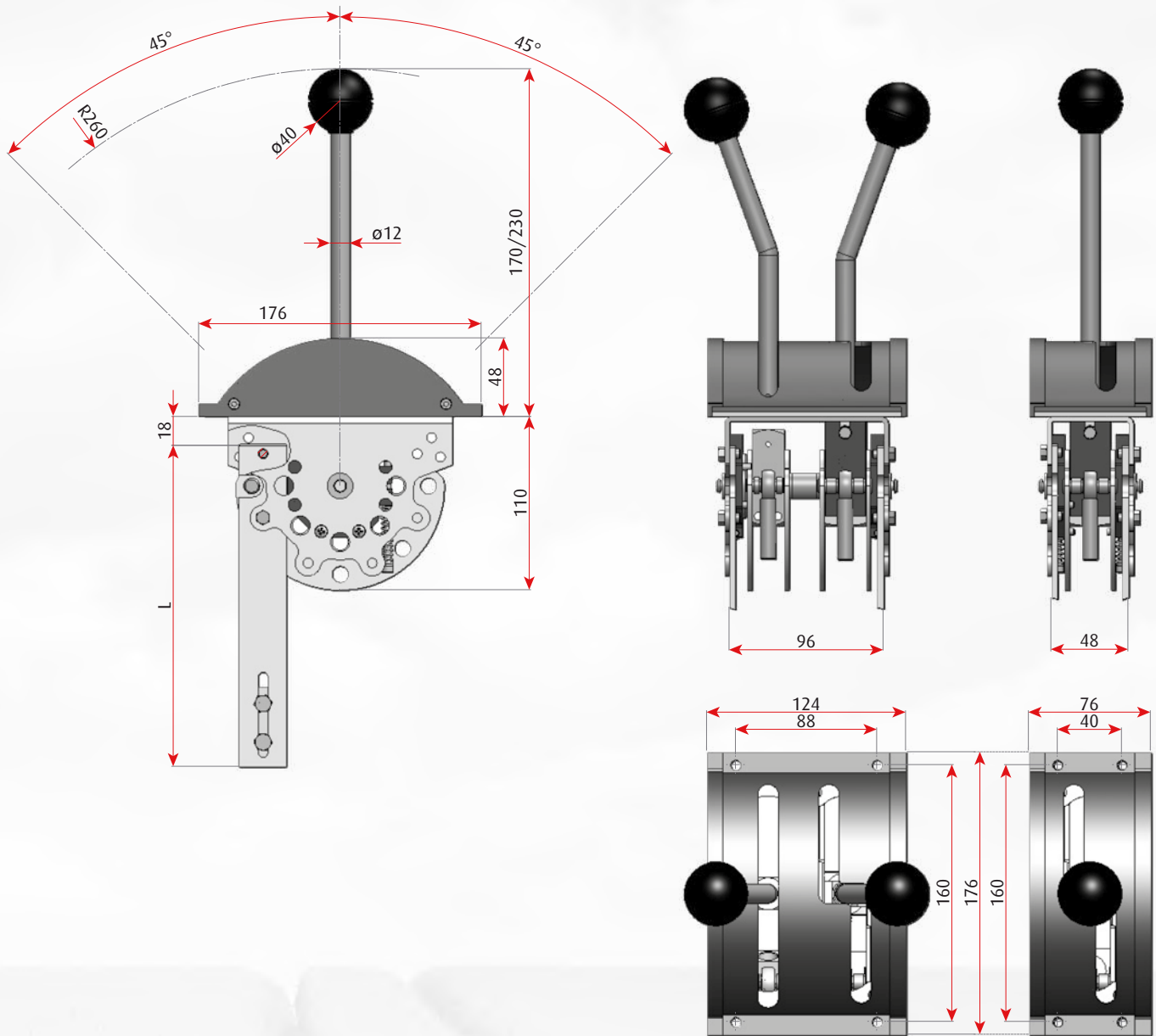

SPECIFICATION

- Lever's maximum bending angle: 45°
- Nominal working force (on the cable): 1500 N
- Gear ratio: 8:1
- Fixing bracket lengths (standard): 200, 252 and 310 mm
- Cables which can be mounted on this lever: V6, V7, V8, 07, Flexball 70, Flexball 95
- Lengths of the lever (standard): 148 or 180 mm

MASK'S PATH AND OTHER OPTIONS

The masks here below schematize different application cases and configurations.

	<p>ETC with swinging lever configured for gear shifter application</p>		<p>ETC with swinging lever configured for an hydrostatic pump application with speed direction inversion</p>
	<p>ETC with plane lever configured for an hydrostatic pump application with speed direction inversion and neutral detent</p>		<p>ETC with plane lever configured to command the throttle</p>
	<p>The first swinging lever commands the hydrostatic pump and the second plane lever commands the throttle</p>		<p>The first swinging lever is used to regulate the speed either forward or reverse and the second swinging lever to select the gear</p>
	<p>The first swinging lever is used to regulate the speed in one direction and the second swinging lever to select the gear</p>		<p>The first swinging lever is used to regulate the speed either forward or reverse and the second swinging lever to select the gear</p>

POSITION OF FIXING CABLE BRACKET

Thanks to a different setting of the fixing cable bracket, it is possible to determine different mounting positions and different push-pull cable exits with respect to the lever (vertical, horizontal and 45 degrees). It follows here below the possible combinations.

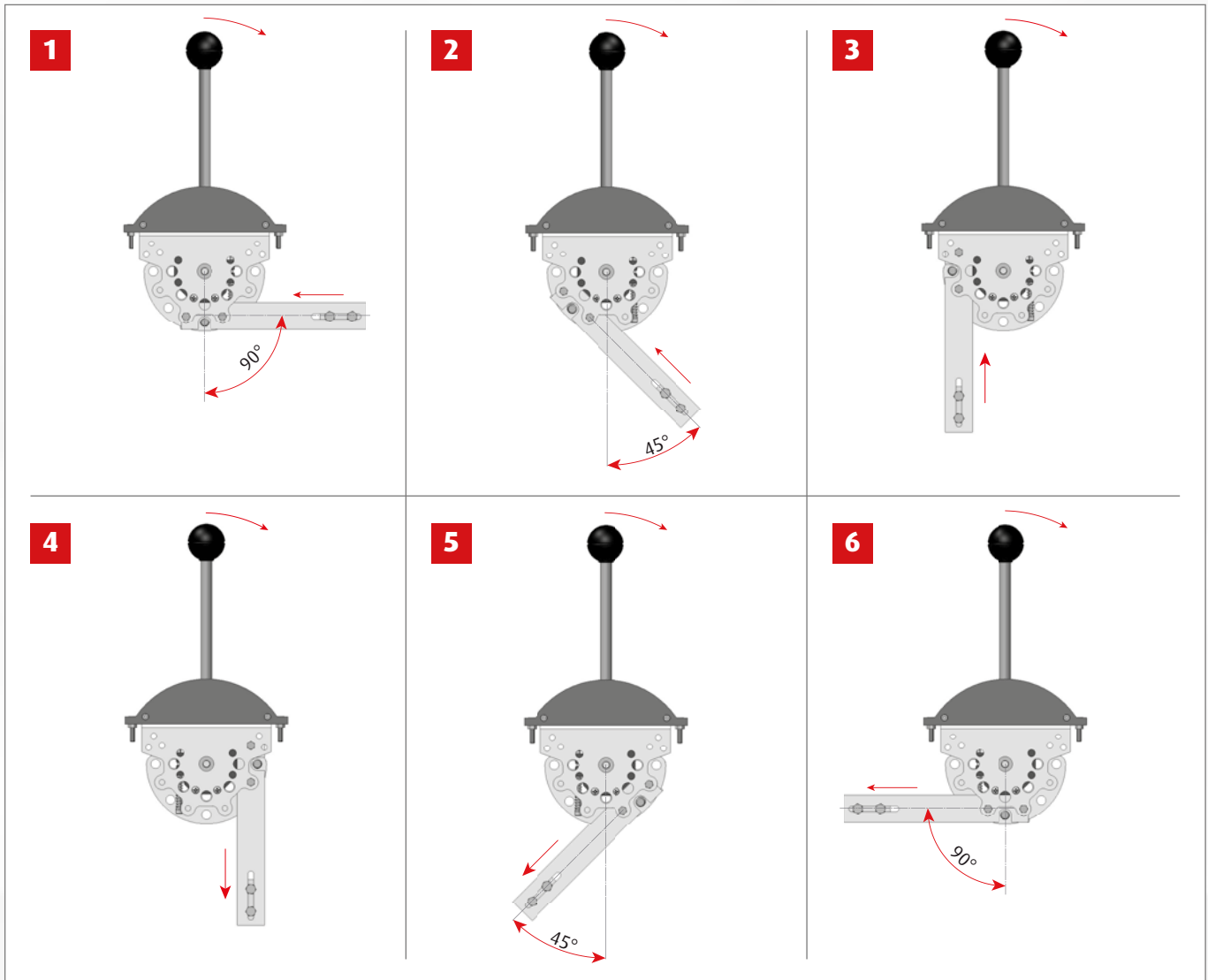

CODES FOR ETC SINGLE FUNCTION WITH PLANE LEVER WITHOUT FRICTION

Length of lever	Eyebolt thread	Type of cable	Position of fixing cable bracket	Length of fixing cable bracket	Code
148 mm	M5	Flexball cable	X	Y	801-1-51XY
		Wire cable	X	Y	801-1-52XY
	M6	Flexball cable	X	Y	801-1-61XY
		Wire cable	X	Y	801-1-62XY
	M7	Flexball cable	X	Y	801-1-71XY
		Wire cable	X	Y	801-1-72XY
	M8	Flexball cable	X	Y	801-1-81XY
		Wire cable	X	Y	801-1-82XY
	M10	Flexball cable	X	Y	801-1-01XY
		Wire cable	X	Y	801-1-02XY
180 mm	M5	Flexball cable	X	Y	801-2-51XY
		Wire cable	X	Y	801-2-52XY
	M6	Flexball cable	X	Y	801-2-61XY
		Wire cable	X	Y	801-2-62XY
	M7	Flexball cable	X	Y	801-2-71XY
		Wire cable	X	Y	801-2-72XY
	M8	Flexball cable	X	Y	801-2-81XY
		Wire cable	X	Y	801-2-82XY
	M10	Flexball cable	X	Y	801-2-01XY
		Wire cable	X	Y	801-2-02XY

Notes:

- "X" (which varies from 1 to 6) identifies the position of fixing cable bracket. Please refer to "Position of fixing cable bracket" at page 64 of "Industrial Products" catalogue
- "Y" identifies the length of the fixing cable's bracket (see page 62 of "Industrial Products" catalogue). Y can be: 1 = 200 mm, 2 = 252 mm, 3 = 310 mm
- The same control is available with friction. In this case for example:
 - 801-1-5131: ETC single, lever length 148, eyebolt thread M5 for Flexball cable, bracket in position 3 with a length of 120 mm; without friction
 - 802-1-5131: ETC single, lever length 148, eyebolt thread M5 for Flexball cable, bracket in position 3 with a length of 120 mm; with friction

CODES FOR ETC SINGLE FUNCTION WITH SWINGING LEVER WITHOUT FRICTION

Length of lever	Eyebolt thread	Type of cable	Position of fixing cable bracket	Length of fixing cable bracket	Code
148 mm	M5	Flexball cable	X	Y	803-1-51XY
		Wire cable	X	Y	803-1-52XY
	M6	Flexball cable	X	Y	803-1-61XY
		Wire cable	X	Y	803-1-62XY
	M7	Flexball cable	X	Y	803-1-71XY
		Wire cable	X	Y	803-1-72XY
	M8	Flexball cable	X	Y	803-1-81XY
		Wire cable	X	Y	803-1-82XY
	M10	Flexball cable	X	Y	803-1-01XY
		Wire cable	X	Y	803-1-02XY
180 mm	M5	Flexball cable	X	Y	803-2-51XY
		Wire cable	X	Y	803-2-52XY
	M6	Flexball cable	X	Y	803-2-61XY
		Wire cable	X	Y	803-2-62XY
	M7	Flexball cable	X	Y	803-2-71XY
		Wire cable	X	Y	803-2-72XY
	M8	Flexball cable	X	Y	803-2-81XY
		Wire cable	X	Y	803-2-82XY
	M10	Flexball cable	X	Y	803-2-01XY
		Wire cable	X	Y	803-2-02XY

Notes:

- "X" (which varies from 1 to 6) identifies the position of fixing cable bracket. Please refer to "Position of fixing cable bracket" at page 64 of "Industrial Products" catalogue
- "Y" identifies the length of the fixing cable's bracket (see page 62 of "Industrial Products" catalogue). Y can be: 1 = 200 mm, 2 = 252 mm, 3 = 310 mm
- The same control is available with friction. In this case for example:
 - 803-1-5131: ETC single, lever length 148, eyebolt thread M5 for Flexball cable, bracket in position 3 with a length of 120 mm; without friction
 - 804-1-5131: ETC single, lever length 148, eyebolt thread M5 for Flexball cable, bracket in position 3 with a length of 120 mm; with friction

CODES FOR ETC DOUBLE FUNCTION

First lever	Second lever	Code
Plane	Plane	8811-Z
	Plane + friction	8812-Z
	Swinging	8813-Z
	Swinging + friction	8814-Z
Plane + friction	Plane	8821-Z
	Plane + friction	8822-Z
	Swinging	8823-Z
	Swinging + friction	8824-Z
Swinging	Plane	8831-Z
	Plane + friction	8832-Z
	Swinging	8833-Z
	Swinging + friction	8834-Z
Swinging + friction	Plane	8841-Z
	Plane + friction	8842-Z
	Swinging	8843-Z
	Swinging + friction	8844-Z

Note:

- "Z" is a two digit number (from 01 to 13) which identifies possible configuration of the ETC

CABLES WHICH FIT WITH LEVER ETC

- Both push-pull cables and Flexball cables can be connected to lever ETC
- The connection between the lever ETC and the cable is always through an eyebolt (see page 24 of "Industrial Products" catalogue)
- Cable's engine side can be configured with any shape as shown at page 16 of "Industrial Products" catalogue

Light duty controls

▶ PLASTIC LEVERS



400



405

▶ ALUMINIUM LEVERS



410



460

▶ SPECIAL LEVERS



415

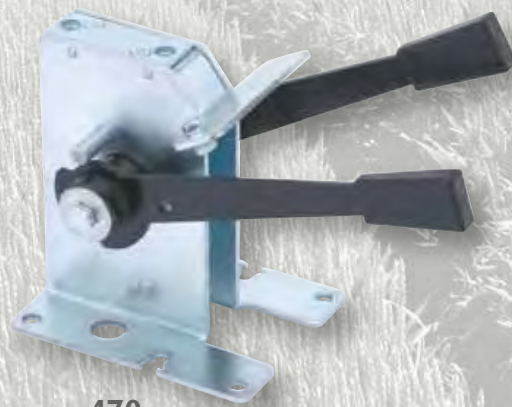

470

400 Plastic levers

It is a side mounting lever made of plastic and stainless steel, with adjustable friction

It is normally used for the command of the throttle. It is available in pull and push-pull version. Thanks to its several versions, it can be mounted in different positions and configurations.

PULL VERSION

To be connected to a pull cable. Max stroke is 60 mm.

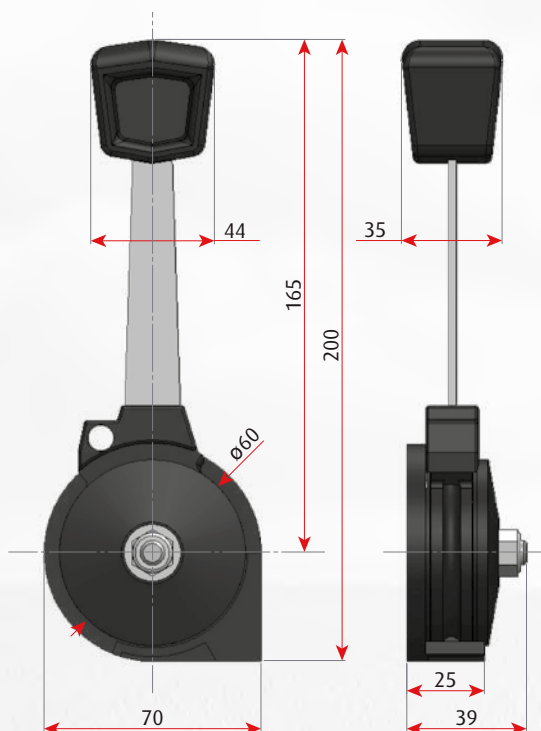

VERSION	CODE
Left mounting, bent	40022-1
Right mounting, bent	40022-2
Left mounting, straight	40022-3
Right mounting, straight	40022-4
Left mounting, through hole	40022-11
Right mounting, through hole	40022-12



PUSH-PULL VERSION

To be connected to a push-pull cable through a fork. It is available in several versions. Max stroke is 60 mm.

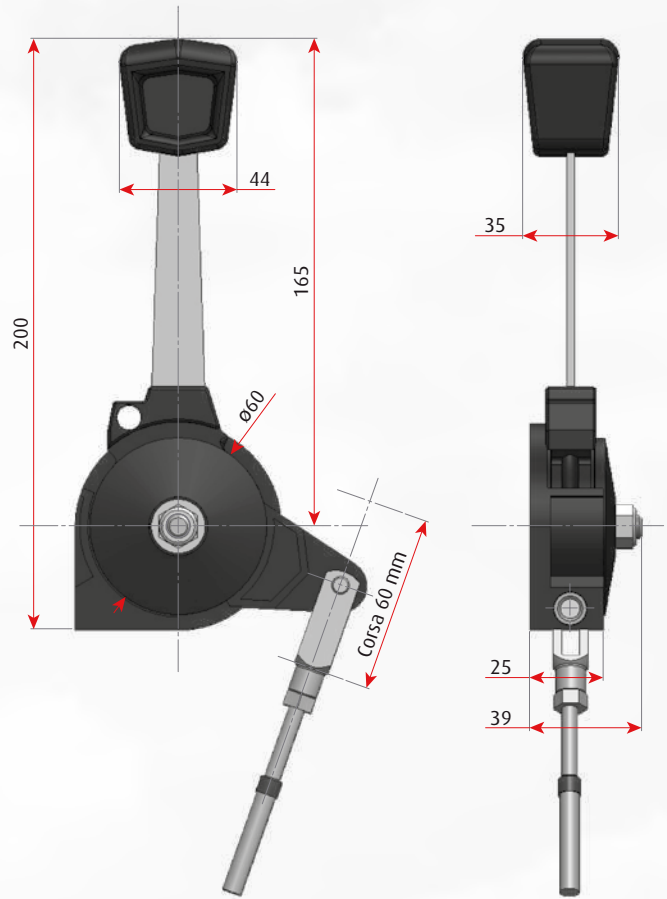

VERSION	CODE
Left mounting, bent	40021-1
Right mounting, bent	40021-2
Left mounting, straight	40021-3
Right mounting, straight	40021-4
Left mounting, through hole	40021-11
Right mounting, through hole	40021-12

RIGHT MOUNTING



LEFT MOUNTING



THROUGH HOLE

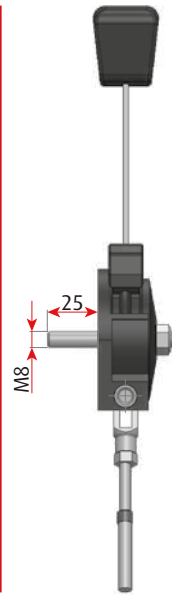

405

Plastic levers

Single side mounting lever

Control lever series 405 is a simple and cost effective side mounting lever with adjustable friction. It is used for the command of the throttle and it works only in pull mode.

The lever is made of plastic and has a maximum stroke of 70 mm.



CODE STANDARD VERSION: 405.01

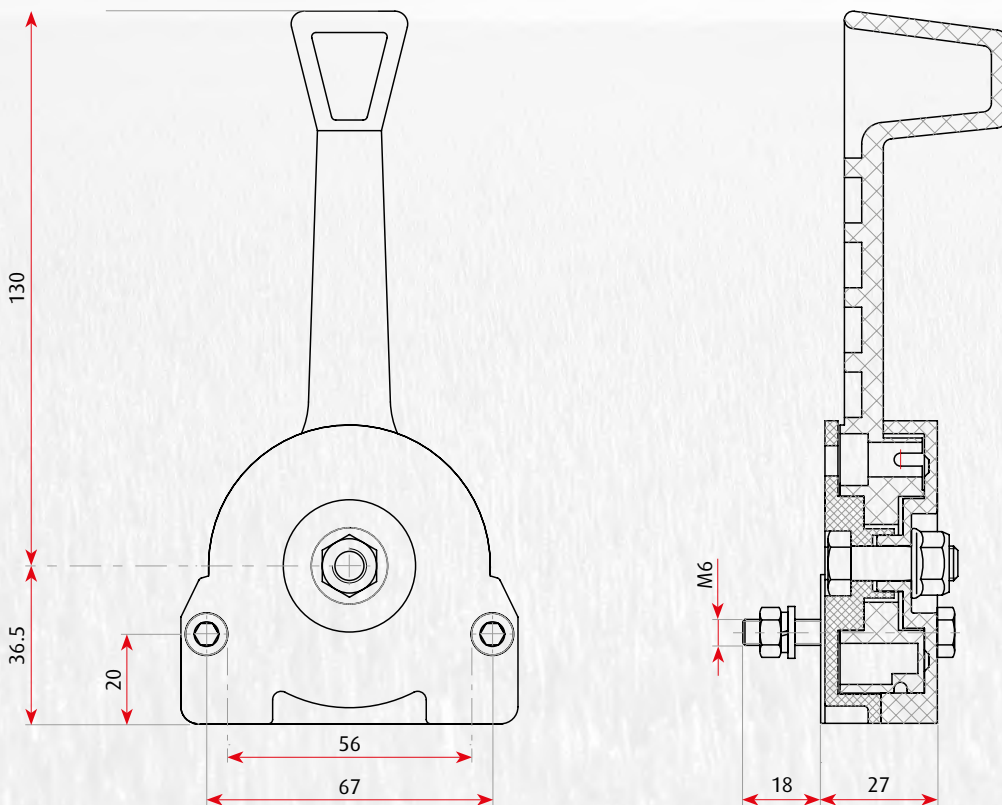

410

Aluminium levers

Control lever series 410 is a simple and robust lever side mounting with adjustable friction

It is normally used for the command of the throttle and for the engine stop. It is available in pull and push-pull version. The lever is made of aluminium and has a maximum stroke of 70 mm. The O-ring offers a high sealing protection.

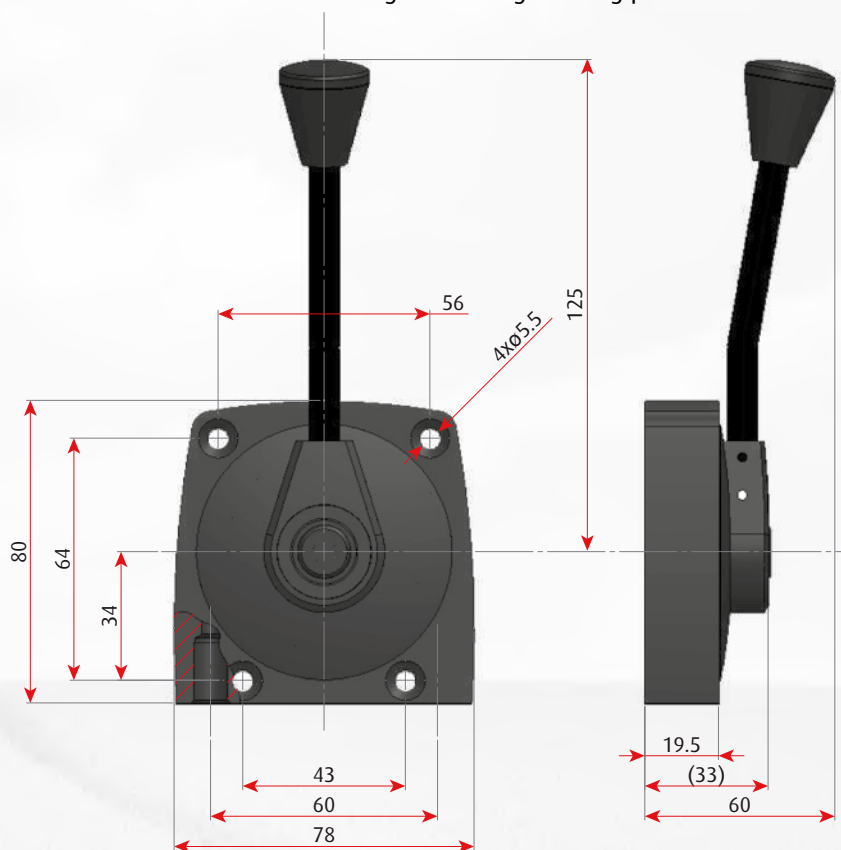

VERSIONS & CODES

Lever 410 is available in many different positions and configuration. It can be connected to a big variety of cables. It follows a list of codes according to the different lever versions. At page 34 of "Industrial Products" catalogue it follows a list of the cables which can be connected to this lever.

Version	Thread A	Outgoing cable position	Code
Pull	M10x1	Right	41022.10-00-0
	1/8 gas	Right	41022.30-00-0
	M10x1	Left	41022.10-00-1
	1/8 gas	Left	41022.30-00-1
Push-pull	M10x1	Right	41022.10-10-0
	1/8 gas	Right	41022.30-10-0
	M10x1	Left	41022.10-10-1
	1/8 gas	Left	41022.30-10-1

415

Special levers

Lever 415 is for machines which, running most of their time at a fixed speed, they can fulfil the new regulations on low emissions without the need to equip the motor with an expensive Electronic Control Unit (ECU). Typical application's examples are machines with EPA homologation

Lever 415 offers the possibility to set minimum and working speeds, clearly identified with detents. Intermediate working speeds are not allowed because a return spring pushes back to minimum the lever and consequently the engine speed goes back to minimum, as soon as the lever exits from the working position.

Each engine is optimized at its working speed where CO₂ emissions are reduced below permitted levels.

Once the working position has been defined during commissioning, the anti-tampering screw fixes permanently the working motor speed.

The turn-off of the motor is actuated by pushing the lever beyond neutral position.

For all the other functions this lever is similar to lever 410 previously described.

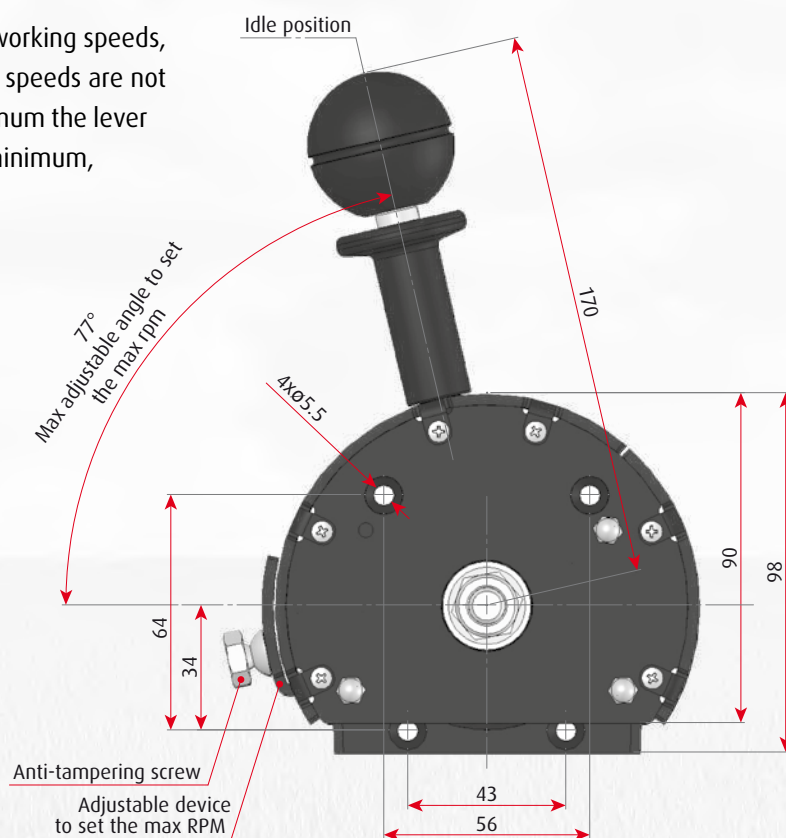

VERSIONS & CODES

Version	Thread A	Outgoing cable position	Code
Pull	M10x1	Right	415.10-00-0
	1/8 gas	Right	415.30-00-0
	M10x1	Left	415.10-00-1
	1/8 gas	Left	415.30-00-1
Push-pull	M10x1	Right	415.10-10-0
	1/8 gas	Right	415.30-10-0
	M10x1	Left	415.10-10-1
	1/8 gas	Left	415.30-10-1

CABLES FOR LEVERS SERIES 410 AND 415

Type	A	Code
Push-pull	M10	0025114-mmmmm
Push-pull	1/8 gas	0025110-mmmmm
Pull	M10	0205114-mmmmm
Pull	1/8 gas	0205110-mmmmm

Type	A	F	Code
Push-pull	M10	10/32	0025118-mmmmm
Push-pull	1/8 gas	10/32	0025119-mmmmm
Push-pull	M10	M5	0025118-5-mmmmm
Push-pull	1/8 gas	M5	0025119-5-mmmmm

Type	A	F	Code
Push-pull	M10	10/32	0025116-mmmmm
Push-pull	1/8 gas	10/32	0025117-mmmmm
Push-pull	M10	M5	0025116-5-mmmmm
Push-pull	1/8 gas	M5	0025117-5-mmmmm

Type	A	Code
Pull	M10	02051111-mmmmm
Pull	1/8 gas	0205113-mmmmm

Type	A	Code
Push-pull	M10	0025111-mmmmm
Push-pull	1/8 gas	00251115-mmmmm
Pull	M10	0205111-mmmmm
Pull	1/8 gas	0205110-mmmmm

Type	A	Code
Pull	M10	02051114-mmmmm
Pull	1/8 gas	02051116-mmmmm

Notes:

- "A" specifies cable lever side thread
- "F" specifies cable engine side thread
- "mmmmmm" is the length of the cable in mm

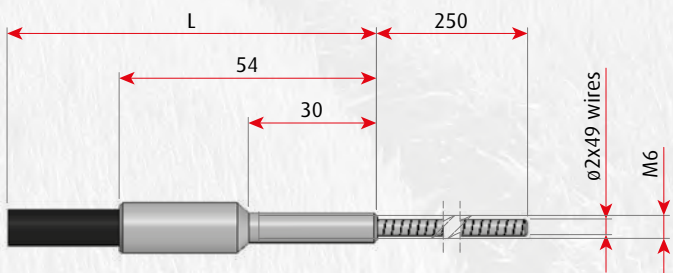
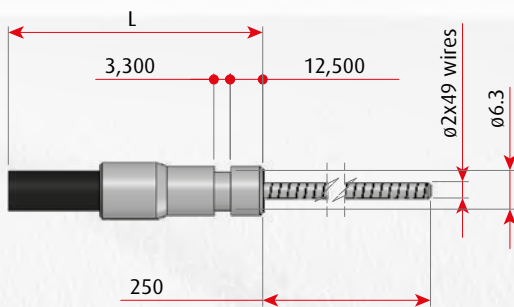
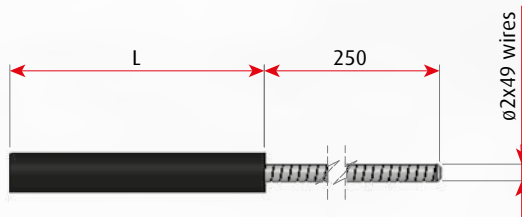
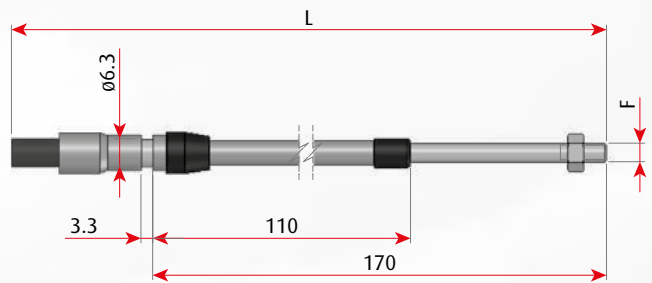
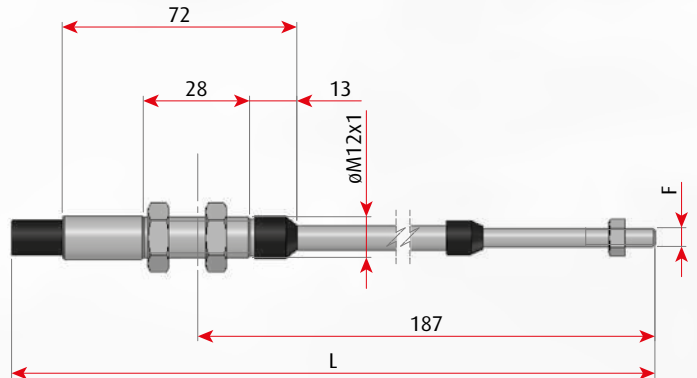
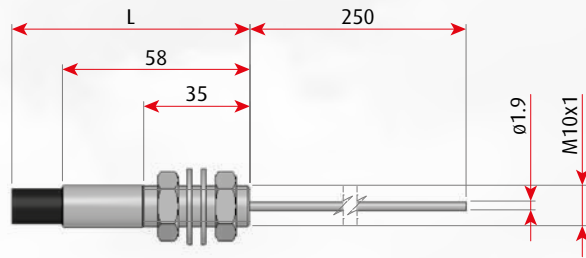

Cables are shown at mid stroke position

460

Aluminium levers

It is very similar to the previous lever but it includes a syringe for the "present man" function. Standard version is with central detent

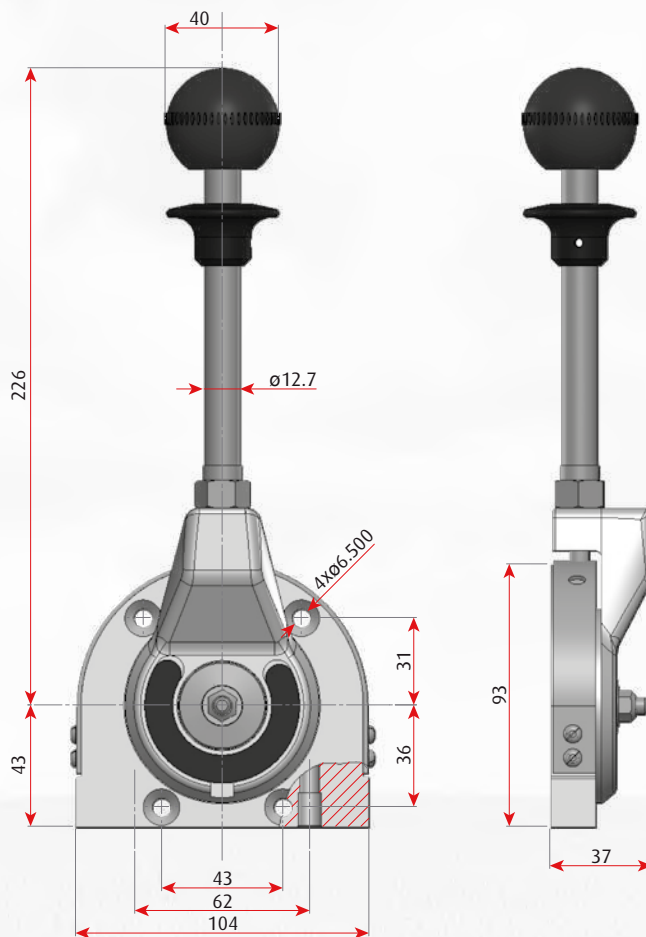

CODES

Version	Thread A	Outgoing cable position	Code
Pull	1/8 gas	Right	460.30-00-0
	1/8 gas	Left	460.30-00-1
Push-pull	1/8 gas	Right	460.30-10-0
	1/8 gas	Left	460.30-10-1

CABLES WHICH FIT WITH LEVER 440 & 460

Type	A	F	Code
07, 07E	1/8 gas	M6X1	0075950-mmmmm

Notes:

- "A" specifies cable lever side thread
- "F" specifies cable engine side thread
- "mmmm" is the length of the cable in mm

470 Special levers

This lever is a seat regulator. Via a pull cable, the lever releases the hook which holds the seat from its fixed position

Lever 470 can be configured for the control of one or two hooks. Each lever releases the movement of a pull cable. A neutral detent and a spring system recall the lever to its locking position as soon as the lever is released.

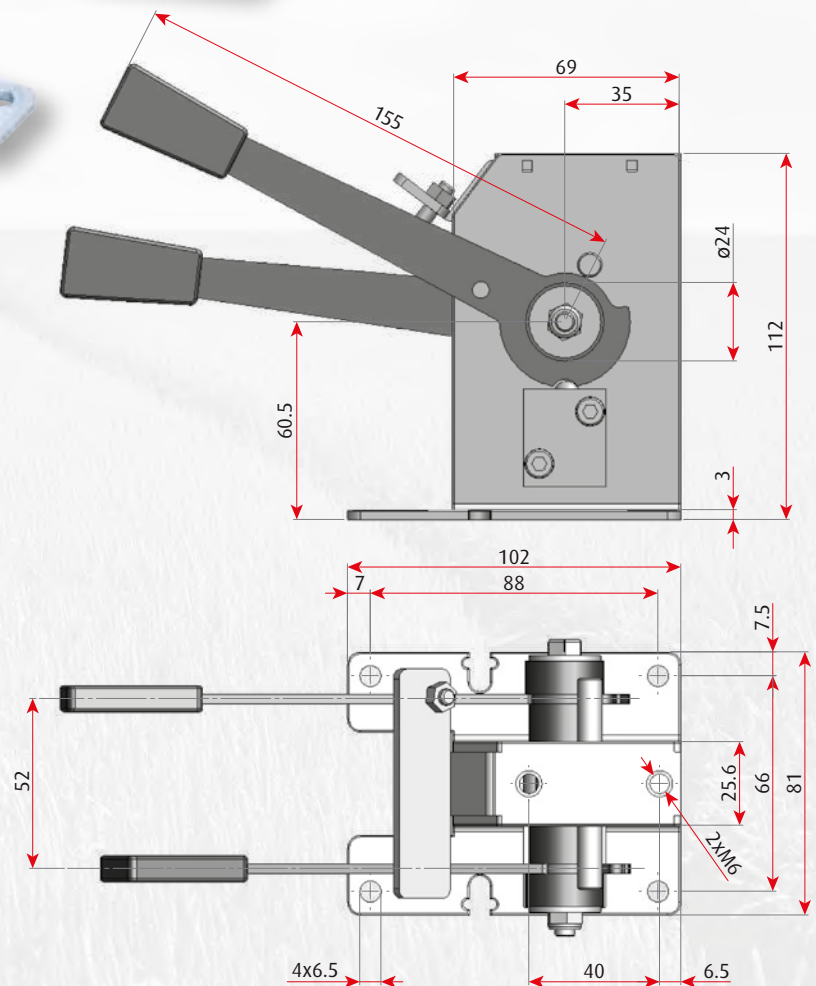
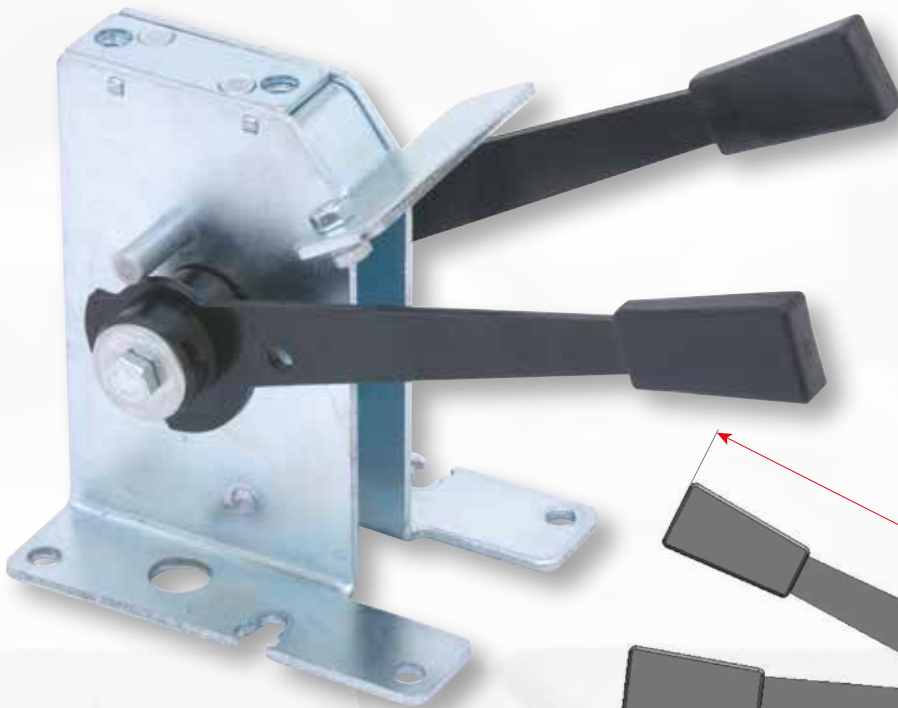



Mechanical Pedals

1200

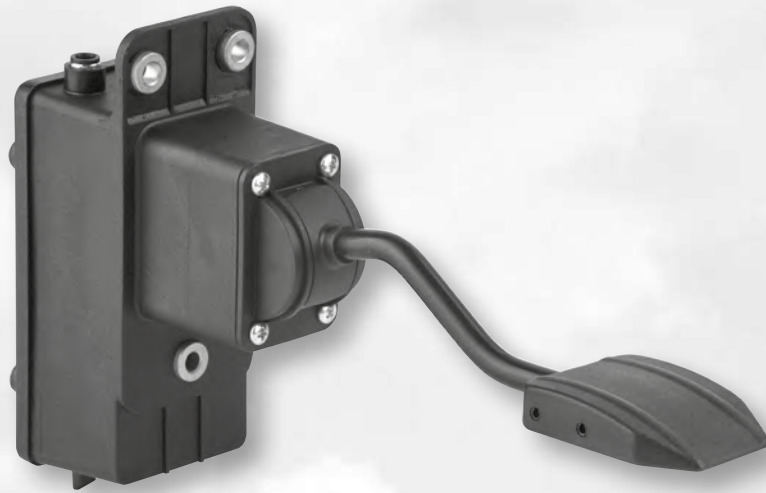

1220



1230

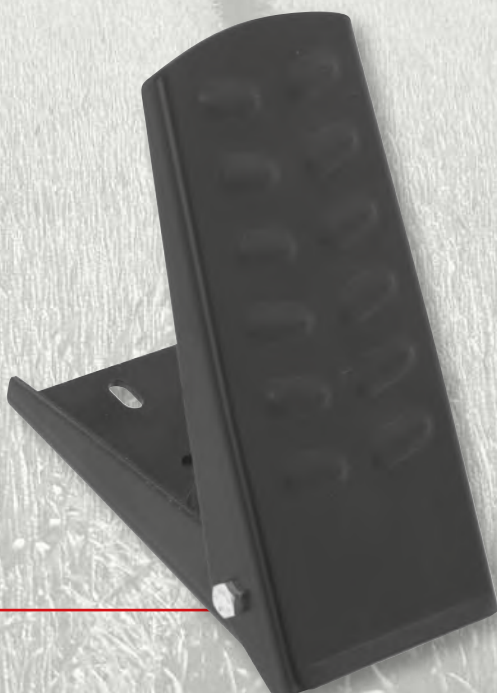

1200

Mechanical throttle pedal

Throttle pedal 1200 is a series of general purpose pedals for wall mounting applications

Made of nylon reinforced with 20% fibreglass, pedal 1200 is very robust and reliable, therefore it can be mounted also on heavy duty construction machines or military vehicles. Environmental contamination is minimised due to the joint combination of the gasket with the mounting flange which segregate the cabin from the engine area. The full sealing between the cabin and the engine area is widely

appreciated in the military sector where the vehicles are specified to travel with the cabin up to one meter below the water level.

Stroke and pedal angles are adjustable via a micrometric screw. Link to the pull cable for the throttle engine is on the lower part of the pedal. Link to the hand throttle control is on the upper side of the pedal.

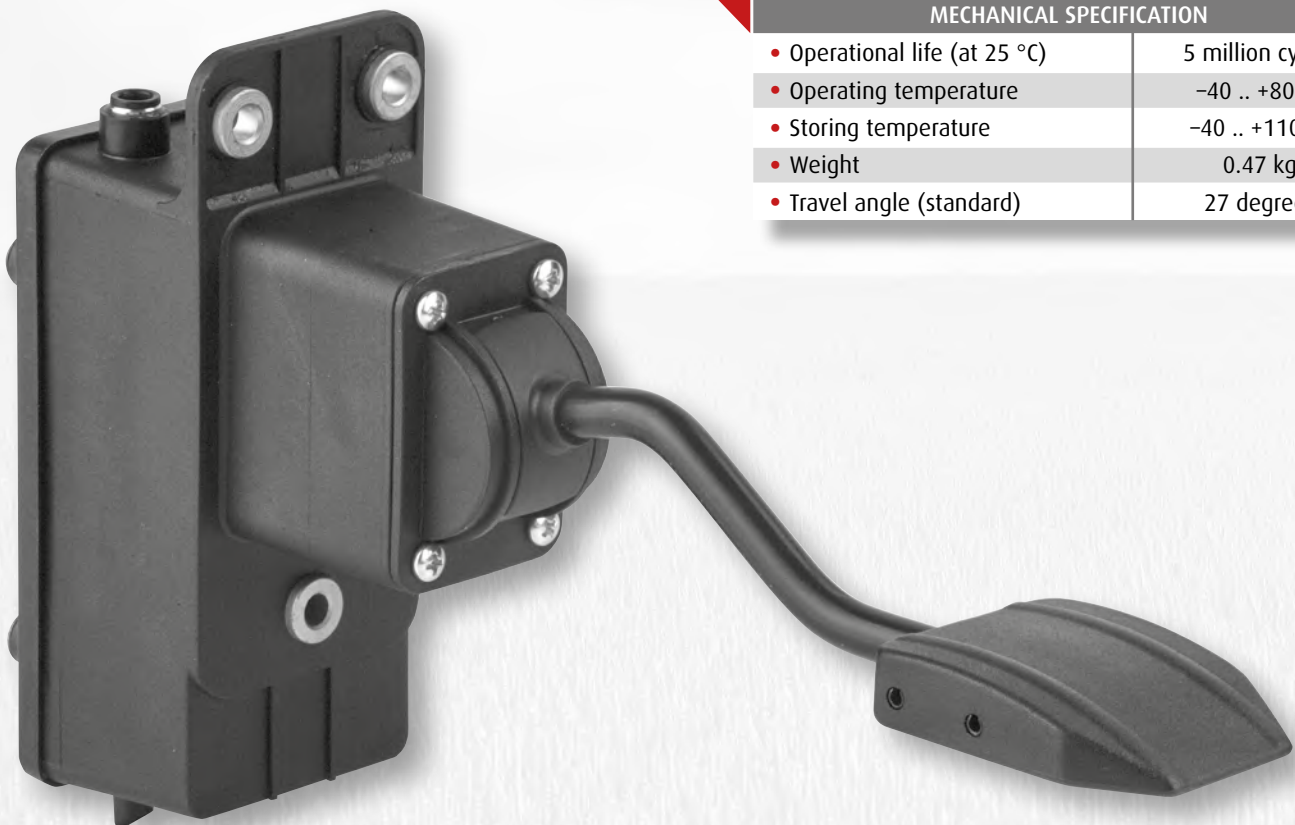

MECHANICAL SPECIFICATION

• Operational life (at 25 °C)	5 million cycles
• Operating temperature	-40 .. +80 °C
• Storing temperature	-40 .. +110 °C
• Weight	0.47 kg
• Travel angle (standard)	27 degrees

PHYSICAL DIMENSIONS AND MOUNTING HOLES

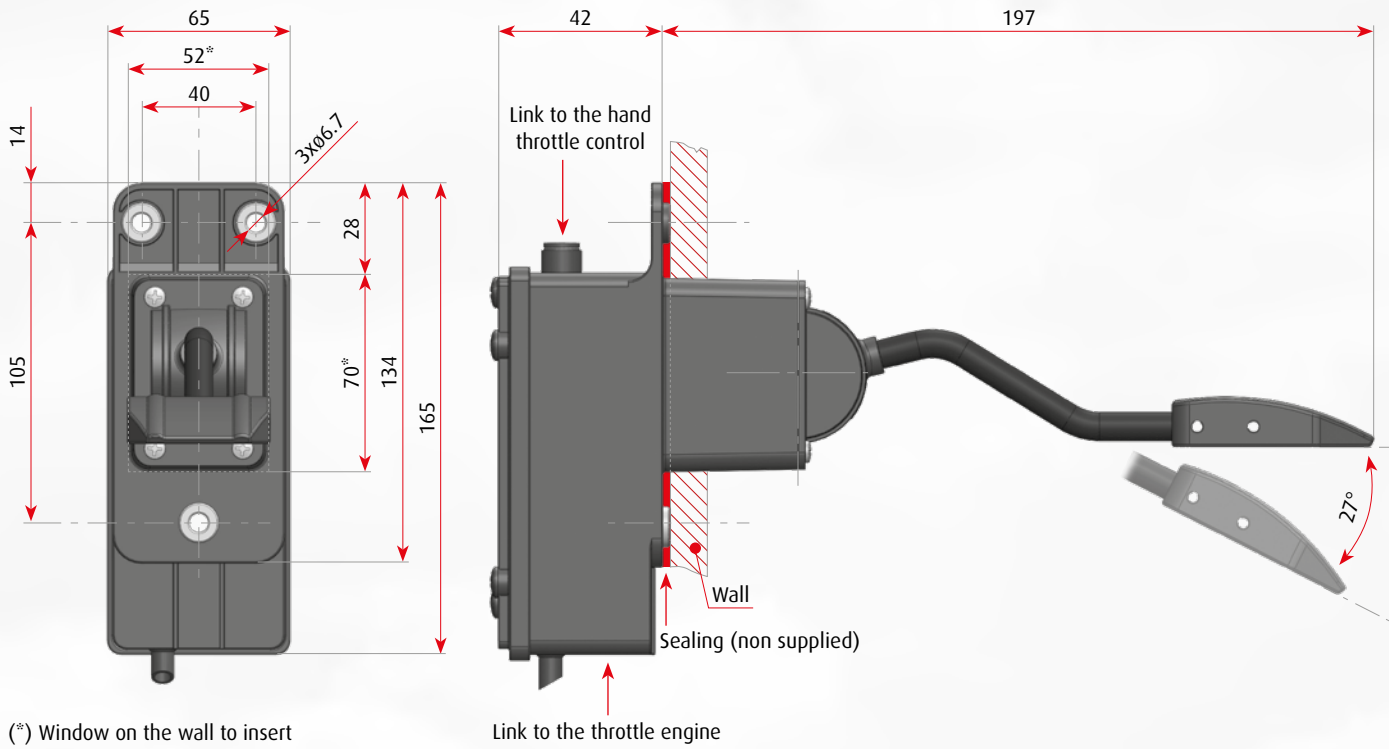

(*) Window on the wall to insert the throttle pedal before the fixing

1220

Mechanical throttle pedal

Throttle pedals 1220, aluminium made for floor mounting applications, are intended for medium and heavy-duty trucks, construction equipment, farm equipment and buses. It can be used in conjunction with any hand throttle lever. The moving mechanism can be mounted below the floor and can rotate, horizontally for any angle within 360° and vertically for 30°, to optimize throttle cable routing.

Pedal 1220

Includes connection to hand throttle control.



CODE

- | | |
|--------|--|
| • 1220 | Version with connection to the hand throttle control |
|--------|--|

MECHANICAL SPECIFICATION

- | | |
|-------------------------------|------------------|
| • Operational life (at 25 °C) | 5 million cycles |
| • Operating temperature | -40 .. +85 °C |
| • Storing temperature | -40 .. +110 °C |
| • Weight | 1.50 kg |
| • Travel angle (standard) | 34 degrees |

Foot Print

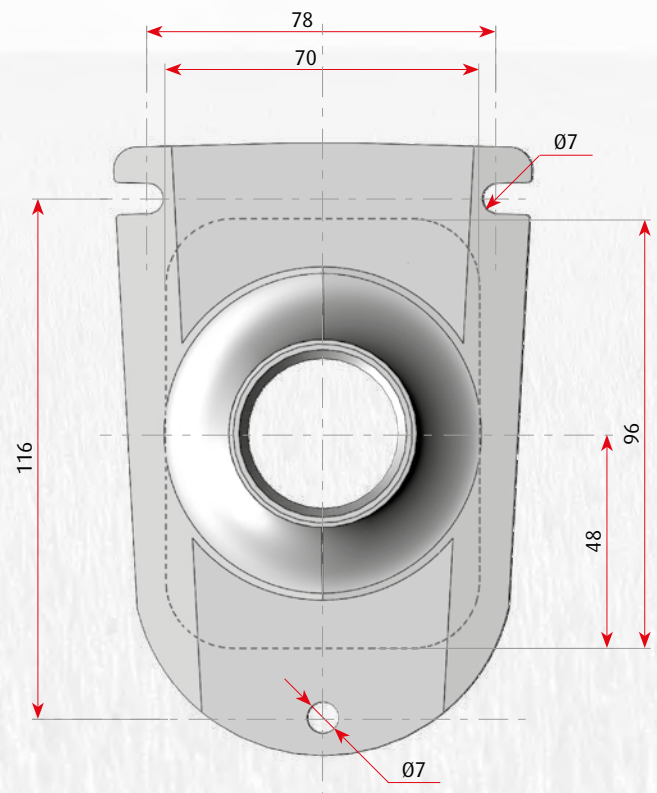

**PHYSICAL DIMENSIONS
AND MOUNTING HOLES**

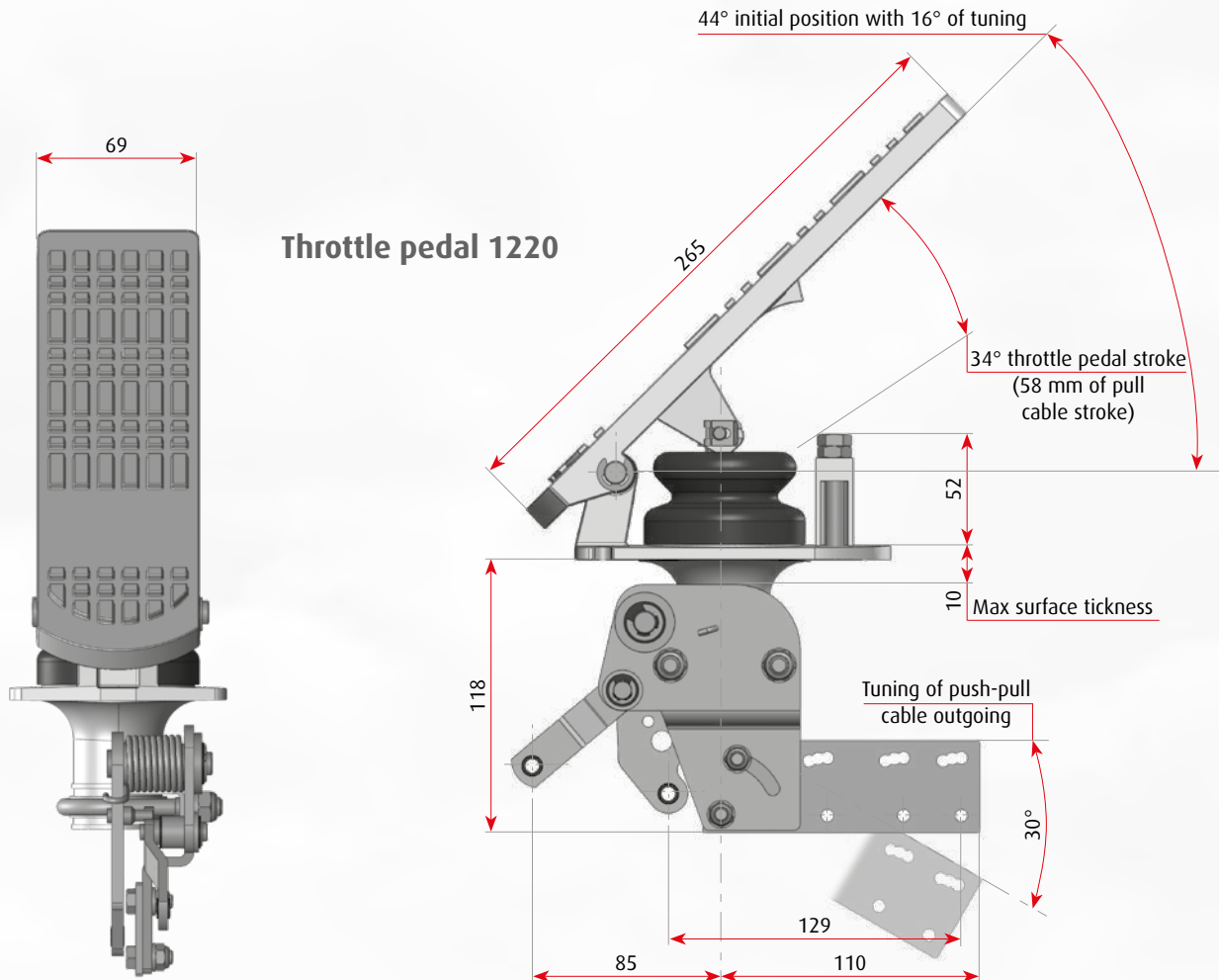

1230

Mechanical throttle pedal

Throttle pedal 1230, metal sheet made for floor mounting applications, is intended for light and medium duty applications

A torsion spring is incorporated for idle position return. Environmental contamination is minimized by a rubber bellow installed between the pad and mounting base. Idle pedal position and throttle travel are adjustable to meet application requirements.

The mechanism can be inserted through a drilling mask in the floor and can rotate 360 to optimize throttle cable routing.

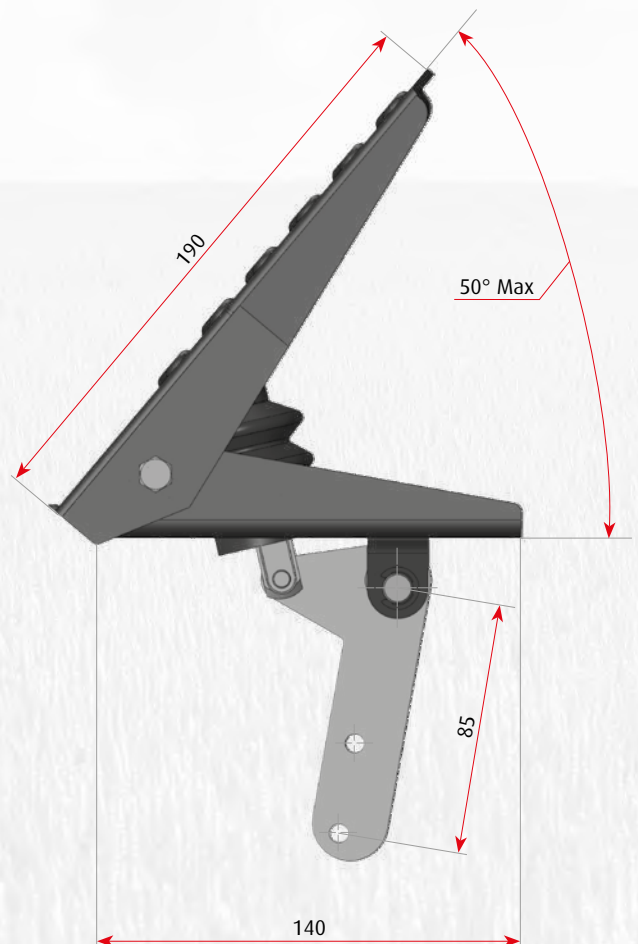
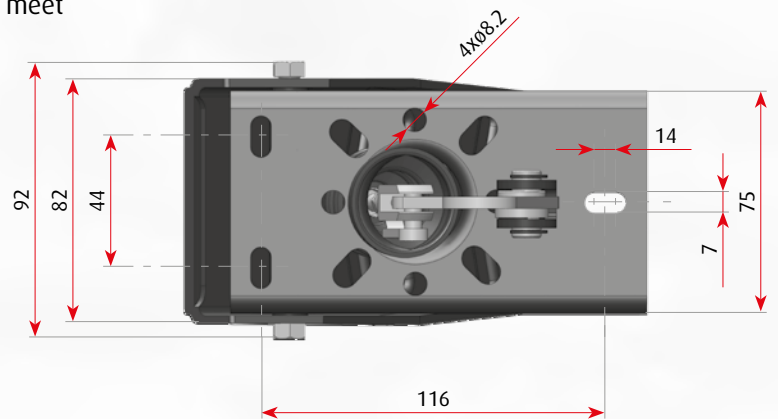

MECHANICAL SPECIFICATION

• Operational life (at 25 °C)	2 million cycles
• Operating temperature	-40 .. +80 °C
• Storing temperature	-40 .. +110 °C
• Weight	1.10 kg
• Travel angle (standard)	50 degrees



Electronic Controls

700 Electronic joystick

Joystick series 700 combines proportional electric outputs with switches, rockers and push button. The above functions can be implemented on many different types of handles. Electrical outputs are full programmable for voltage, current, PWM and CANBus.

The electronic circuit is fully protected against water and any kind of contaminants. Thanks to its particular enclosure, IP67 is guaranteed for the whole electronic circuits and environmental contamination is minimized.

Measuring position is through Hall effect sensors which guarantee a precise proportional control in the whole working area with programmable reaction time for any kind of movement of the joystick's lever.

Programming via PC guarantees full flexibility in the setting of the interface profiles. Its strong structure guarantees long life operation also in case of misused conditions.

The joystick is available in the versions:

- single axis
- dual axis (simple)
- dual axis with full range movements
- dual axis with limited crossed movements

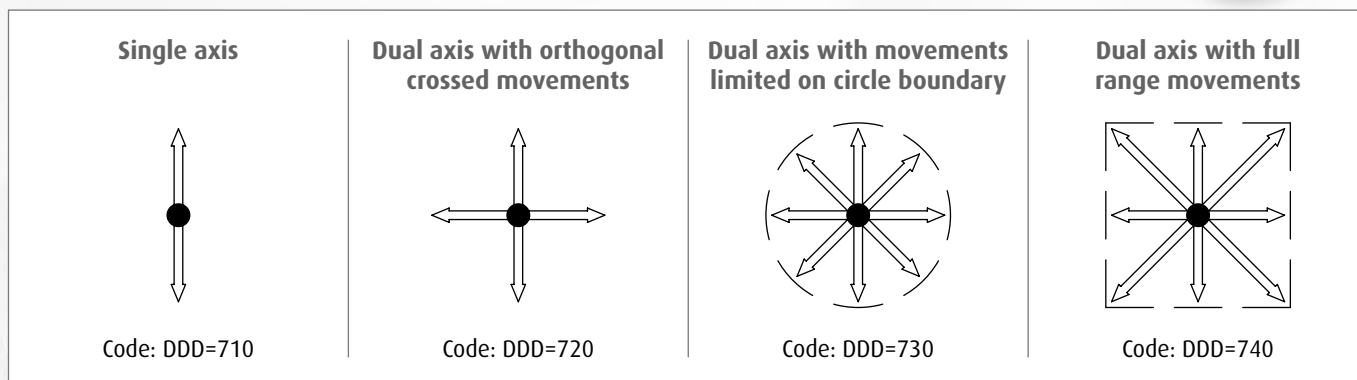

It can be configured either for top or for bottom mounting; the base mechanism, combined with specific accessories produces different joystick versions:



▲ Base mechanism

With simple knob,
without push-button

Top mounting
Bottom mounting

With ergonomic handle,
with push-buttons

Top mounting
Bottom mounting

DIMENSIONS & CONFIGURATIONS

Joystick with simple knob, without push-button

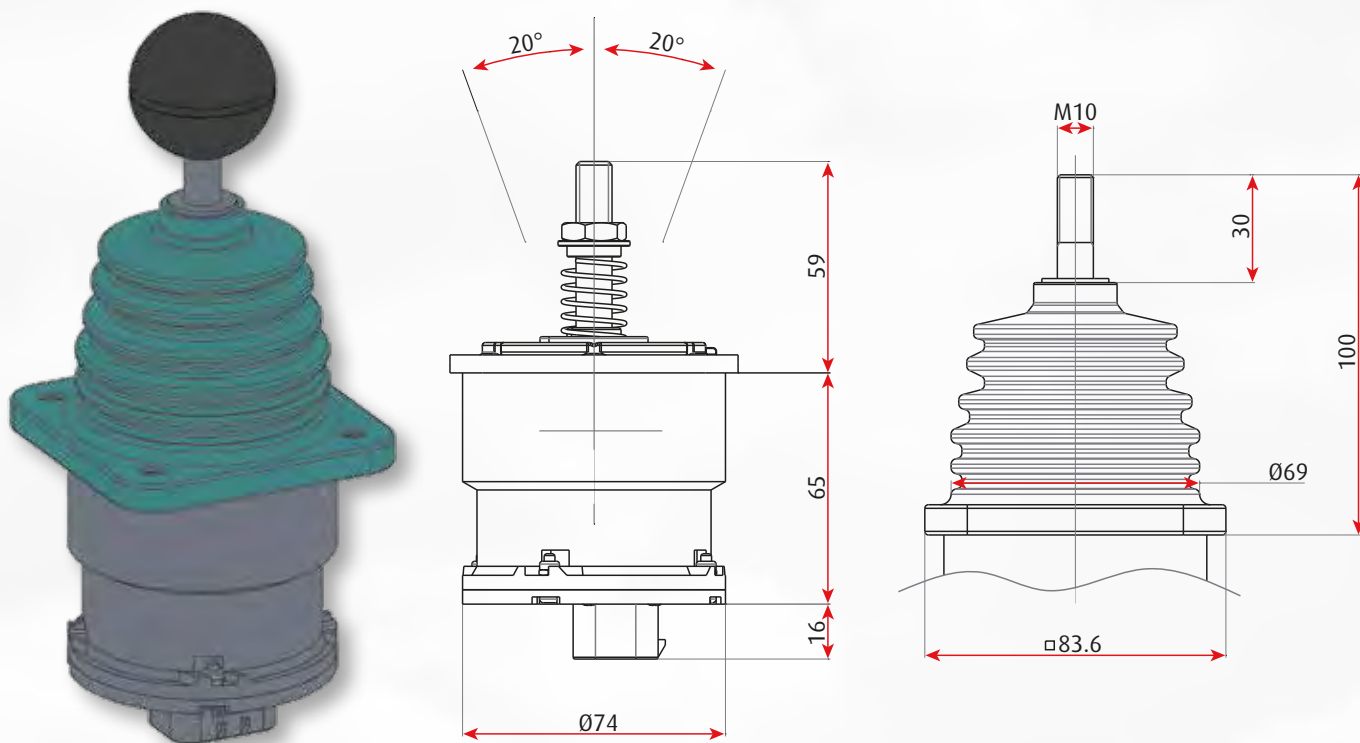

No knob, thread M10

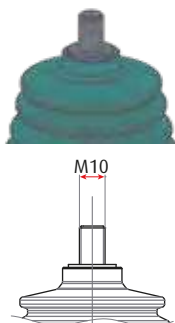

Code: K=0

Round knob

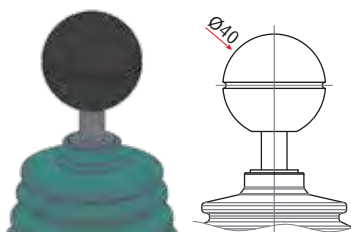

Code: K=1

Ogival knob

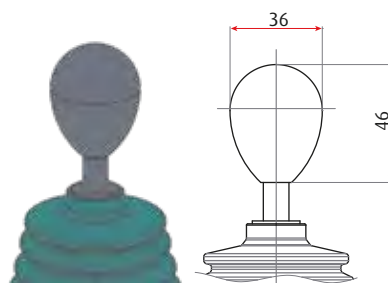

Code: K=2

Top mounting

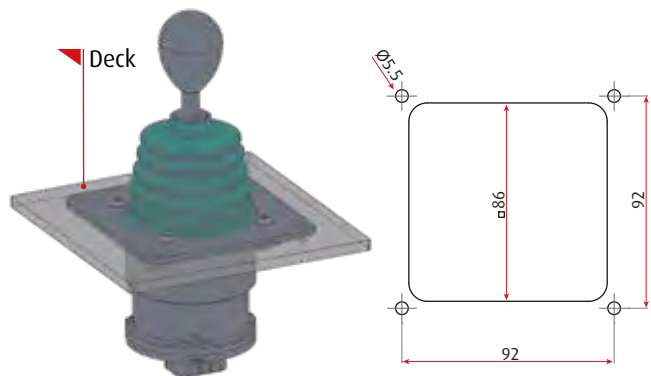

Code: J=0

Bottom mounting

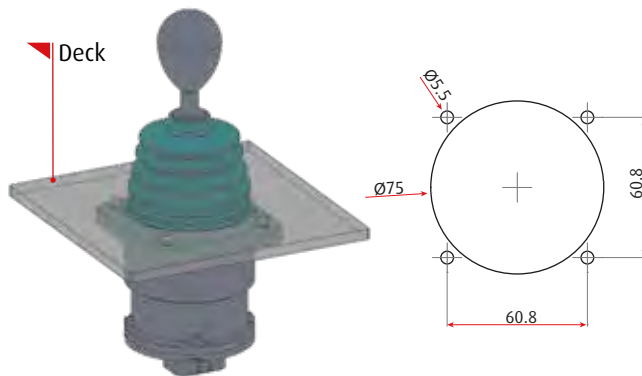

Code: J=2

JOYSTICK WITH ERGONOMIC HANDLE

Handle type 1725

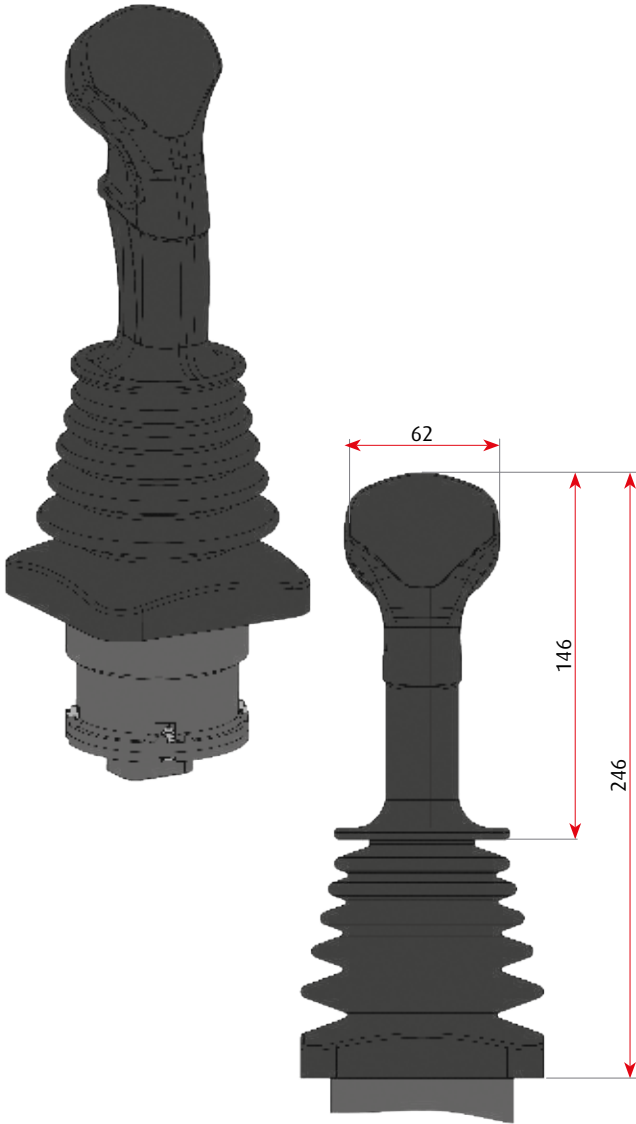

Code: K=3

Handle type 1730

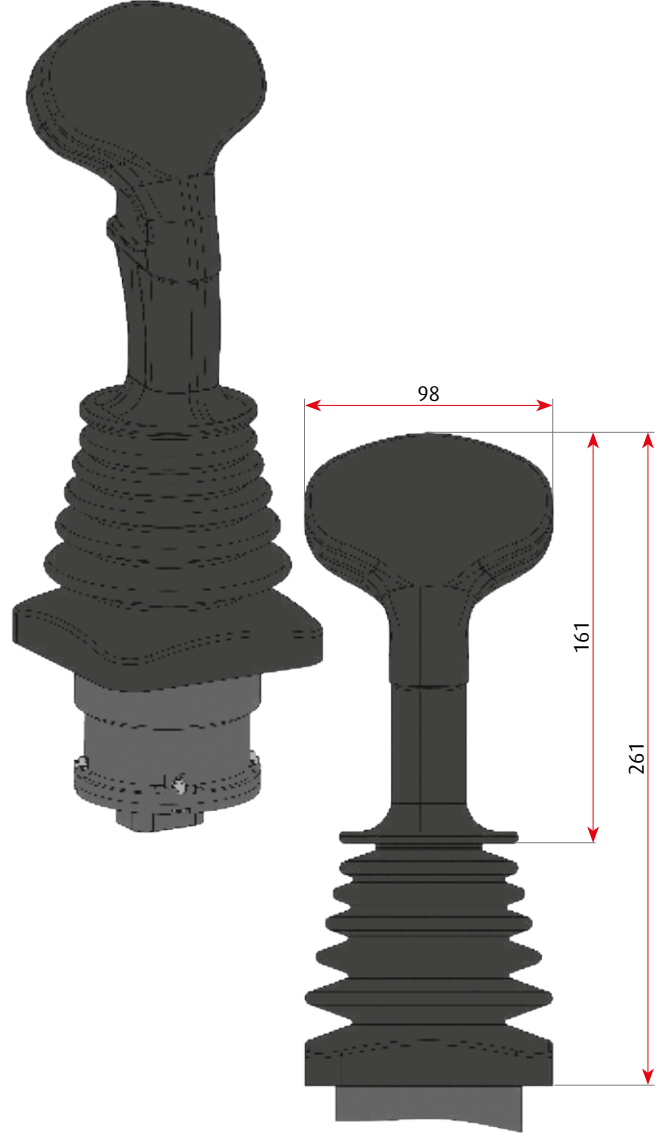

Code: K=4

Top mounting

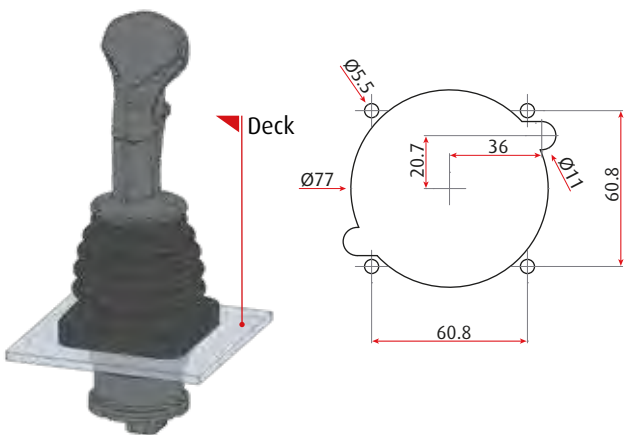

Code: J=1

Bottom mounting

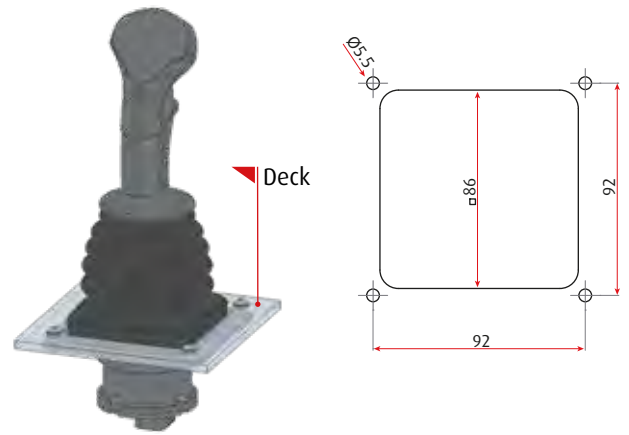

Code: J=3

SPECIFICATION

MECHANICAL AND GENERAL SPECIFICATION	
Life	5 million cycles
Operating temperature	-40°C : 85°C
Protection	IP67
Travel on axis	20°
Travel at 45 °	28°
Force to come out of centre	600 gr
Force at 20 °	750 gr
Force at 28 °	900 gr
Max static load on X axis (190 mm from the rotation point)	1000 N
Max static load on Y axis (190 mm from the rotation point)	1000 N
Max static load on Z axis	500 N

ELECTRICAL SPECIFICATION	
Sensor	Hall effect
Supply voltage	8V to 30V
Maximum input current	180 mA at 24V
Output voltage range	0.5 : 5V (with 2.5V in neutral position)
Output current range (PWM option)	400 : 1600 mA (12VDC); 200 : 800 mA (24VDC)
Electric signals	Galvanically insulated
Resolution and update rate	10 bit update rate 0.1 ms
Correlation in case of 2 signals	Better than 1% in the whole joystick range

CONNECTOR PINOUT

Electronic connector is placed under the base of the joystick body. This is a standard TE connector Vertical HDR for printed circuit board applications with 14 poles. It should be matched with TE connector code 776273-1 or similar.

According to the different electronic joystick versions, it follows the cabling:

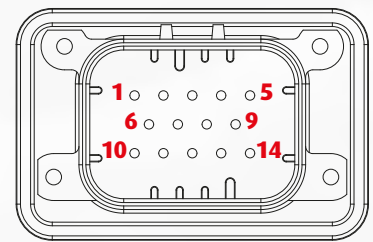

Pin	Joystick versions			
	DAC (Voltage)	PWM (Colis Driver)	CAN Bus 1.2	CAN Bus 2.0
1	Out 1 - South/North	Out - West (+)	PNP Din 1	NPN DIN 1
2	Out 1 - West/East	Out - East (+)	PNP Din 2	NPN DIN 2
3	Out 2 - South North		PNP Din 3	NPN Din 3
4	Out 2 - West/East		Can H	Can H
5		Out - West/East (-)	Can L	Can L
6	+V Supply (from 8 to 32 Vdc)			
7	Factory reserved - Do Not Connect			
8	Factory reserved - Do Not Connect			
9	GND			
10	D _{out} : out of death band E	Out - South (+)	PNP Din 4	NPN Din 4
11	D _{out} : out of death band W	Out - North (+)	PNP Din 5	NPN Din 5
12	D _{out} : out of death band N	D _{out} : out of death band WE	PNP Din 6	NPN Din 6
13	D _{out} : out of death band S	D _{out} : out of death band SN	PNP Din 7	NPN Din 7 - Pot 1
14	GND	Out - South/North (-)	PNP Din 8	NPN Din 8 - Pot 2

Notes:

- Inputs Din PNP have to be supplied from 5 to 24 V
- Inputs Din NPN have to be shorted to GND
- Outputs D_{out} are PNP at voltage of +V Supply, I_{max} = 100 mA

CODING SYSTEM FOR ELECTRONIC JOYSTICK

DEVICE				MOUNTING		TYPE OF SIGNAL	HANDLE		PUSH BUTTONS			SPECIAL CUSTOM PROJECTS	
D	D	D	-	J	.	S	K	.	P1	P2	.	X	X

The code is composed of 10 digits which correspond to the following:

D	D	D
---	---	---

 define the product and the joystick version:

DDD = 710 single axis

DDD = 720 dual axis with orthogonal crossed movements

DDD = 730 dual axis with movements limited on circle boundary

DDD = 740 dual axis with full range movements

J

 defines the type of mounting:

J = 0 bottom

J = 1 top

S

 defines the type of signal:

S = 0 voltage

S = 1 PWM

S = 2 4-20 mA

S = 3 Canbus

K

 defines the type of handle
(for complete description of handles refer to Chapter 7 of the Industrial Catalogue):

K = 0 without handle

K = 1 simple knob, round

K = 2 simple knob, ogival

K = 3 handle type 1725 (ergonomic handle)

K = 4 handle type 1730 (ergonomic handle XL)

P1	P2
----	----

 define the number, type and position of switches:

P1 = number of push buttons low current (200 mA)

P2 = number of push buttons high current (4 A)

X	X
---	---

 A numbering system 0 to 99 is used to define special projects, cable length, number of poles, type of connector, special switches and their position, dead man function, rocker, etc.

THE JOYSTICK PROGRAMMER

With this Pctool you define the correlations between the lever and the output signals.

The two axis are completely independent; for each axis it is possible to define:

- the dead band around neutral detent
- signal profiles for north-south axis and respectively for east-west axis. Points which define the transfer function are:
 - starting point after dead band zone
 - value at medium travel
 - end of travel
- ramp-up time (in ms)

If the electronic joystick is connected to the PC, through the Joystick Programmer you can verify the results of your programming and eventually change the parameters and verify runtime the effect of the new setting.

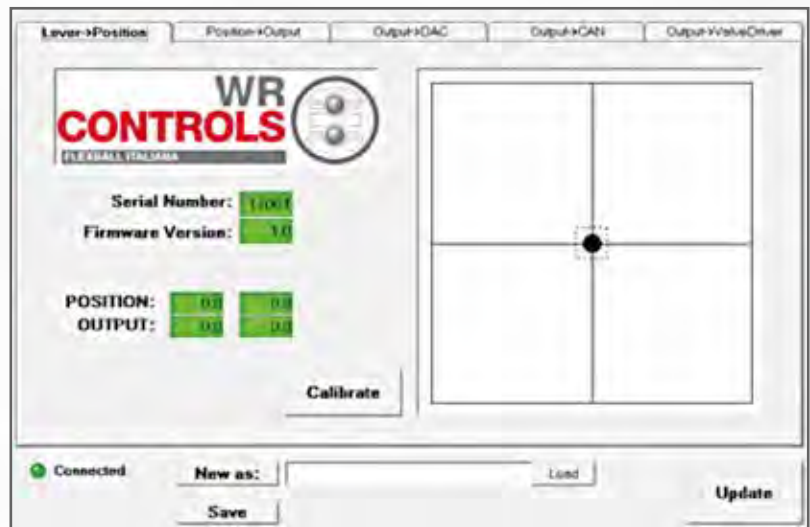

VOLTAGE

There are available 4 analogue and 4 digital signals. The analogue signal is fully programmable within the range 0-5 V and can represent:

1. either a half stroke (from centre of axis to one of the poles)
2. or a full stroke from one pole to its opposite (from e.g. South to North pole or for West to East pole).

In case 1, there is only one analogue signal per each half stroke.

In case 2, are available two voltage signals per every full stroke. From programming it is possible to keep the programming of the 2 axis completely independent or to make setting of axis WE (West -East) equal to SN (South-North).

The 4 digital signals detect the out of centre position. Centre or Dead band position is fully programmable as described at previous page. Each out of centre position signal can withstand a current of 500 mA and its profile is according to the drawing here below.

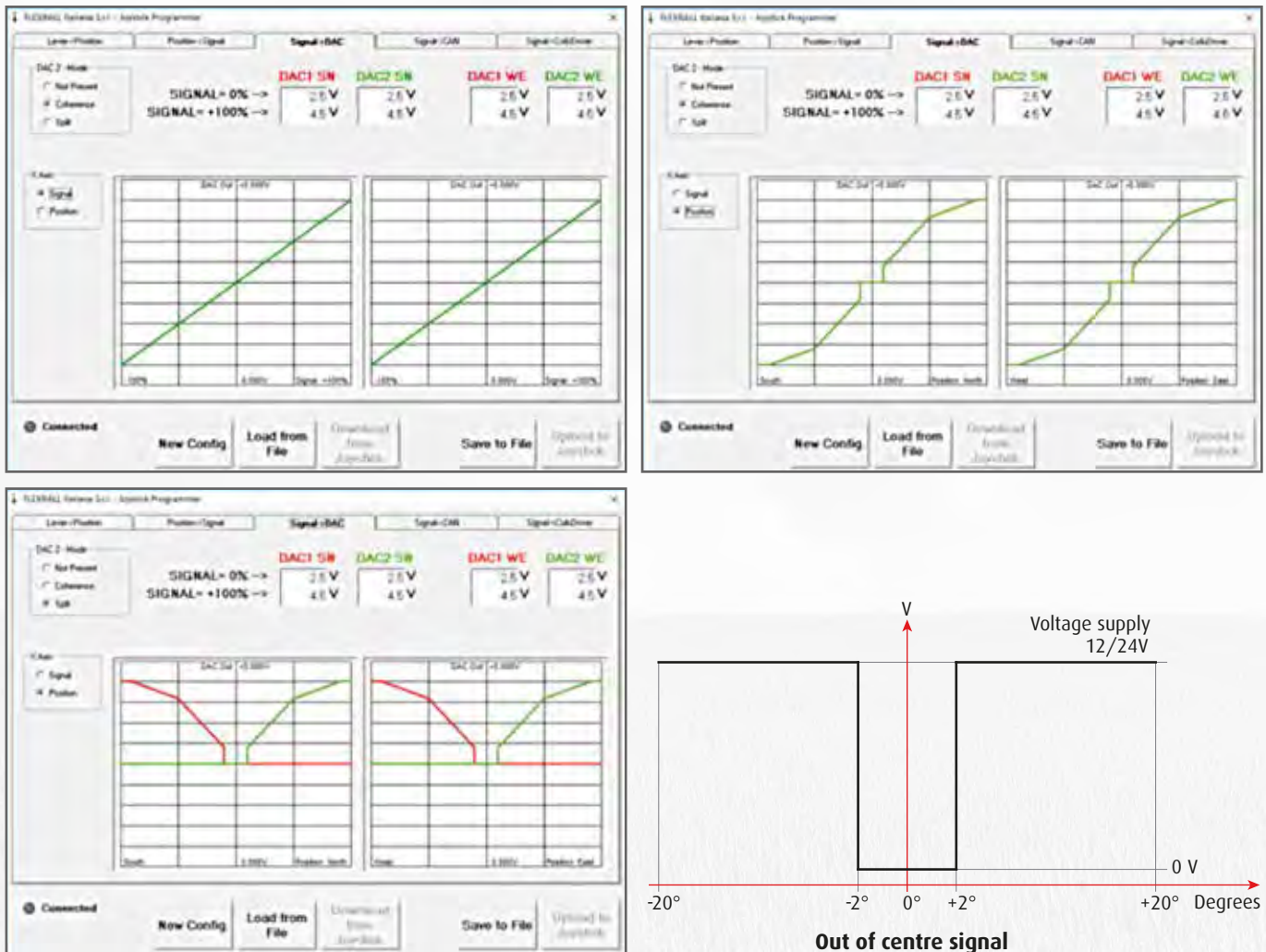

PWM

There are available 4 PWM and 4 digital signals. Each PWM signal is fully programmable within the range 0-100% and represents the half stroke from centre of axis to the pole.

The 4 digital signals detect the Out of centre position. Dead band position is fully programmable as previously described.

Each out of centre position signal can generate a current of 500 mA and its profile is according to the drawing here below.

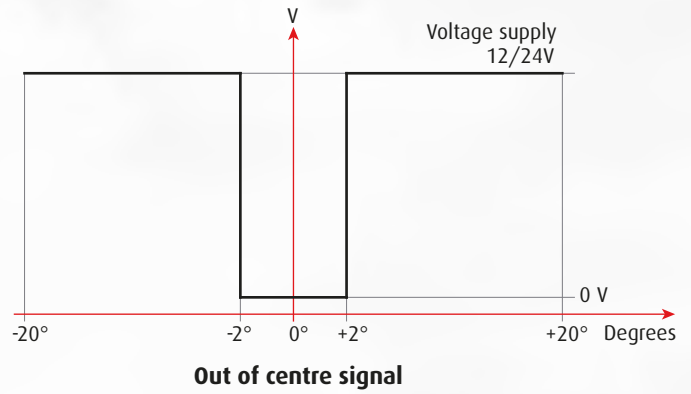

CANBUS IS ACCORDING TO SAE J1939

FLEXBALL Italiana S.r.l. - D-0700 Electronic Joystick Programmer

Lever->Position
 Position->Signal
 Signal->DAC
 Signal->CAN
 Signal->CoilsDriver

Baudrate:
 120 Ohm Term.
 Axis MaxValue:
 Inv. Axis S/N
 Inv. Axis W/E
 Pots MaxValue:
 Inv. Pot. 1
 Inv. Pot. 2

Switch 1	Switch 2	Switch 3	Switch 4	Switch 5	Switch 6	Switch 7	Switch 8
<input type="checkbox"/> Toggle	<input type="checkbox"/> Toggle	<input type="checkbox"/> Toggle	<input type="checkbox"/> Toggle	<input type="checkbox"/> Toggle	<input type="checkbox"/> Toggle	<input type="checkbox"/> Toggle	<input type="checkbox"/> Toggle
<input type="checkbox"/> Negate	<input type="checkbox"/> Negate	<input type="checkbox"/> Negate	<input type="checkbox"/> Negate	<input type="checkbox"/> Negate	<input type="checkbox"/> Negate	<input type="checkbox"/> Negate	<input type="checkbox"/> Negate
<input type="checkbox"/> HandON							

Tx1: ID=0x1000. Rate=50 ms
 Tx2: Disabled
 Rx: Disabled

CAN Bus ID: Hex
 Refresh Time: ms

Byte 0	Byte 1	Byte 2	Byte 3	Byte 4	Byte 5	Byte 6	Byte 7
AxisSN lsb	AxisSN msb	Axis WE lsb	Axis WE msb	Switches	None	None	Counter

Axis SN - WE: the value of "Signal" in one direction, Range = +/- MAXVALUE
 Axis S - N - W - E: the value of "Signal" in one only versus, Range = 0 / MAXVALUE

Connected

From here you have full programming access. In the red frame are depicted the parameters and function for the general setting of the communication.

Parameter/function	Range/number/configuration
Baudrate	From 125 Kbit/s to 1 Mbit/s
End of line/Ohm termination	120 Ohm
Accuracy of position signal of axis X and Y	From 100 to 10.000 bit with the possibility to invert the signal
Analogue input (for e.g. potentiometer, max 2)	From 100 to 10.000 bit with the possibility to invert the signal
Switches or digital input (max 8)	Momentary - Toggle - Negate - Hand on (for only switch 1)

Analog and digital signals come from the potentiometers, pushbuttons, switches, capacitive switches which are mounted on the knob. Their signals enter into the joystick, are then converted and transmitted via the CANbus network.

In the yellow frame it is possible to configure further parameters and functions. It follows the list:

Parameter/function	Range/number/configuration
CANBus ID	HEX format
Transmission refresh time	From 10 to 1000 ms
Message package	8 bytes

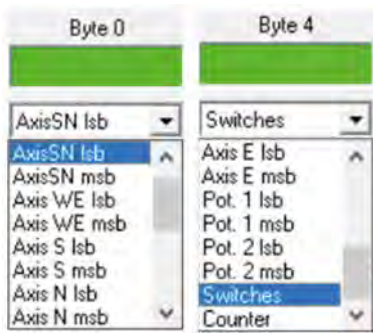

Communication is via messages of 8 bytes. Each byte is freely configurable. Here beside are reported some of the possible information that can be stored in each byte.

For the communication between the joystick and the other devices of the CANBus network you have available as standard 3 frames: TX1, TX2 and RX1.

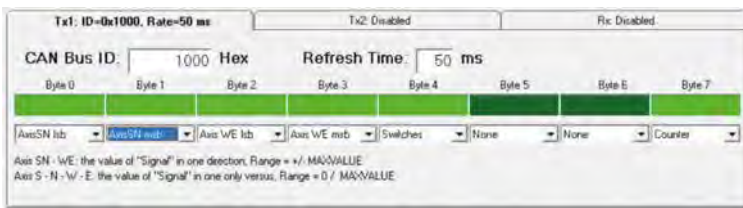

Tx1 = transmission frame (main frame)

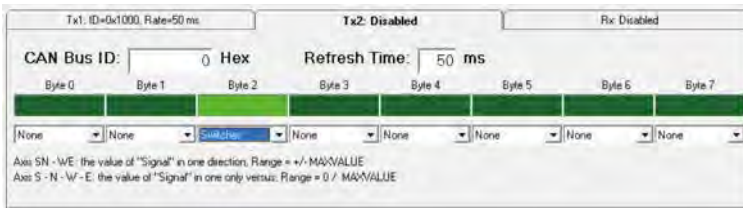

Tx2 = transmission frame; it is a second further frame



Rx = receive frame, mainly used to control from remote (switch on/off) the LEDs on the knob

APPLICATION EXAMPLES

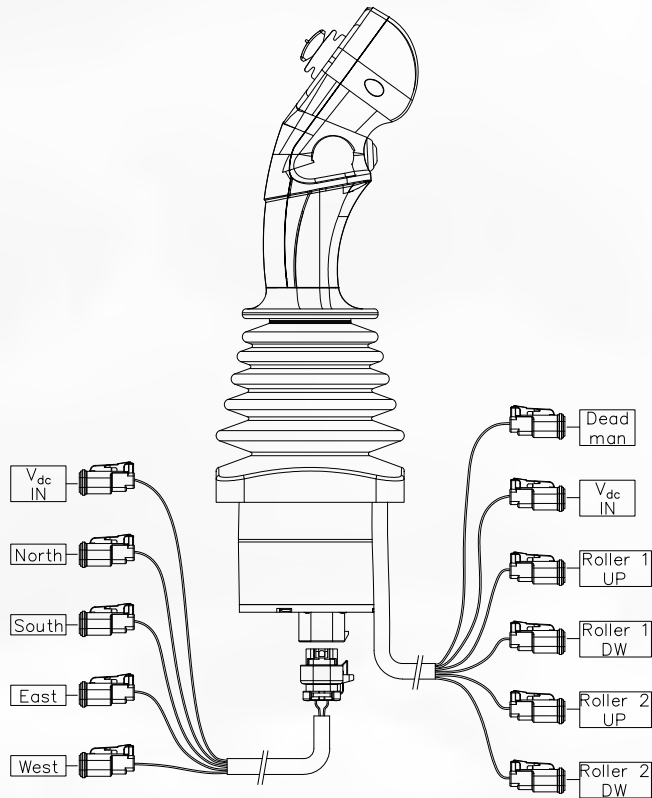

Stand alone solution

The joystick can directly command the proportional valves of an hydraulic distributor.

There 8 PWM signals:

- 4 signals are proportional to the joystick movements
- 4 signal are generated on the handle via proportional rollers.

Decentralized solution

The commands go from the joysticks to a Power Distribution Unit via a digital signal (CANBus). The Decentralized Power Unit generates the commands to the hydraulic distributor valves (power PWM signals). The distance between the joystick and the Decentralized Power Unit can be of any length, giving full flexibility to the installation.

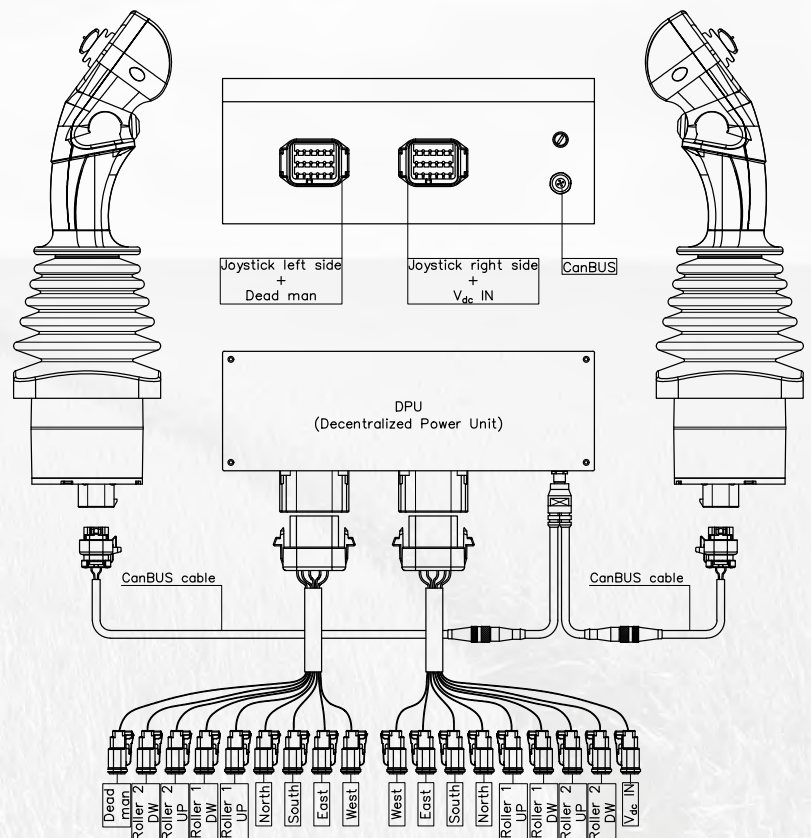



Hand Throttle Controls



600



610



620



630

600

Electronic control lever

This series of electronic control levers is suitable for a variety of applications, including industrial vehicles, agricultural machines, heavy duty and any other kind of special machines

The die cast lever is simple, very robust and thanks to the non-contact sensor technology, it can operate in harsh environments in continuous operation with high reliability and long working life. It can be mounted either in the cabin or in open air. The sensor-less technology guarantees a longer life time, if compared with a lever with potentiometer. Thanks to its different versions, 1 or 2 channels, with or without idle validation switch, PWM, current and CANBus, this lever can interface with almost all electronic motors.

Upon request lever 600 can be equipped with company logo. Electrical cable can also be configured in the desired length, number of poles, type of connector.

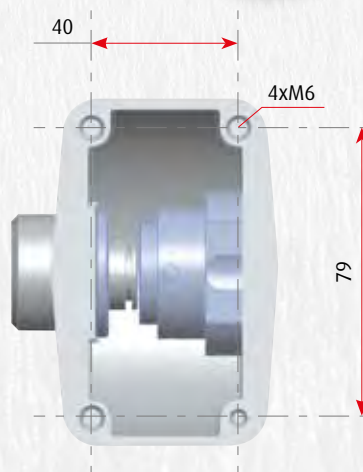
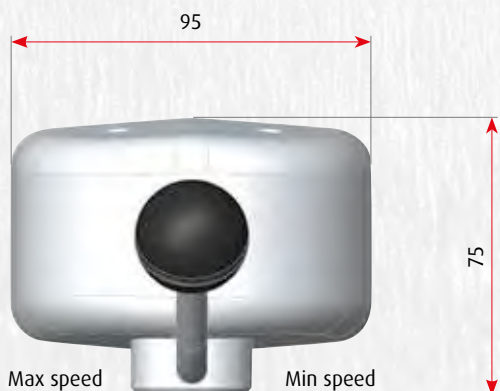
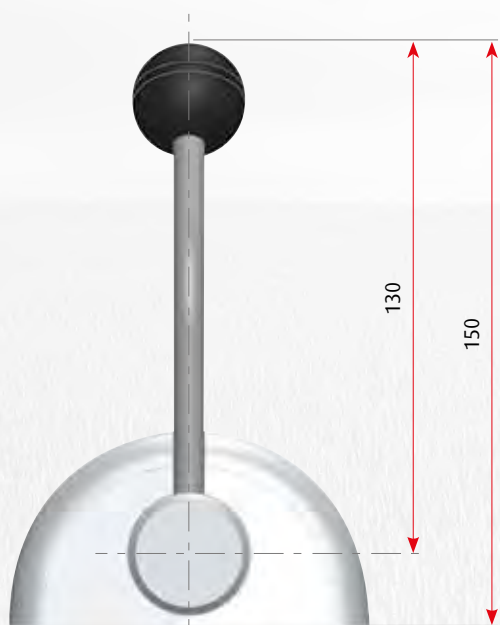

MECHANICAL SPECIFICATION	
• Operational life (at 25 °C)	10 million cycles
• Operating temperature	-40 .. +90 °C
• Storing temperature	-40 .. +110 °C
• Weight	0.50 kg
• Rotation	On bushes
• Mechanical friction	Adjustable
• Travel angle	80 degrees

ELECTRICAL SPECIFICATION (VERSION WITH VOLTAGE SIGNALS)	
• Sensor	Hall effect
• Electrical signal	Voltage output galvanically separated
• Kind of signal	Ratiometric
• Linearity	2%
• Accuracy	2%
• Power supply	5 V ±10%
• Current consumption	<10 mA (per each channel)
• Minimum load resistance	4.7 K Ω
• Maximum load capacitance	10 nF

ELECTRONIC LEVER WITH 2 VOLTAGE CHANNELS

Below are reported the typical standard configuration of control lever with 1 channel, 2 channels voltage output and 1 channel voltage + 1 Idle Validation Switch. Electrical cable standard length is 0.5 meter but any other length can be defined when ordering. Factory standard connector is AMP Metripack 6 poles but it can also be defined when ordering.

INTERFACE CONFIGURATION	CODE	SIGNAL OUTPUT
• 1 channel	600.01.00	CH1 = voltage signal
• 2 channels	600.02.00	CH1 = voltage signal; CH2 = voltage signal
• 1 channel + 1 idle validation switch	600.03.00	CH1 = voltage signal; CH2 = IVS

For a complete overview of Lever 600 configured with different possible interfaces, please refer to section ECU Interfaces.

610

Electronic control lever

Electronic Single axle control

It is a single axle control, suitable for a variety of applications, including industrial vehicles, agricultural machines, heavy duty machines and any other kind of special machines. It is equipped with a friction which can be adjusted from factory and with a neutral detent. Multifunction handle is available with up to 6 switches and with the dead man function. It is possible to define either with signal or with high current switches.

The electronic circuit is fully protected against water and any kind of contaminants. Thanks to its particular high IP enclosure, the control can be mounted either in cabin or in open air and it can operate in harsh environments with continuous operation, high reliability and long working life.

Measuring position is through Hall effect sensor with one or two channels. It is available with any kind of electronic interface: 1 or 2 voltage channels, with or without idle validation switch, PWM, current, CANBus.

Wall mounted M12 connectors are positioned on the lower part of the lever.



PHYSICAL DIMENSIONS AND MOUNTING INSTRUCTIONS

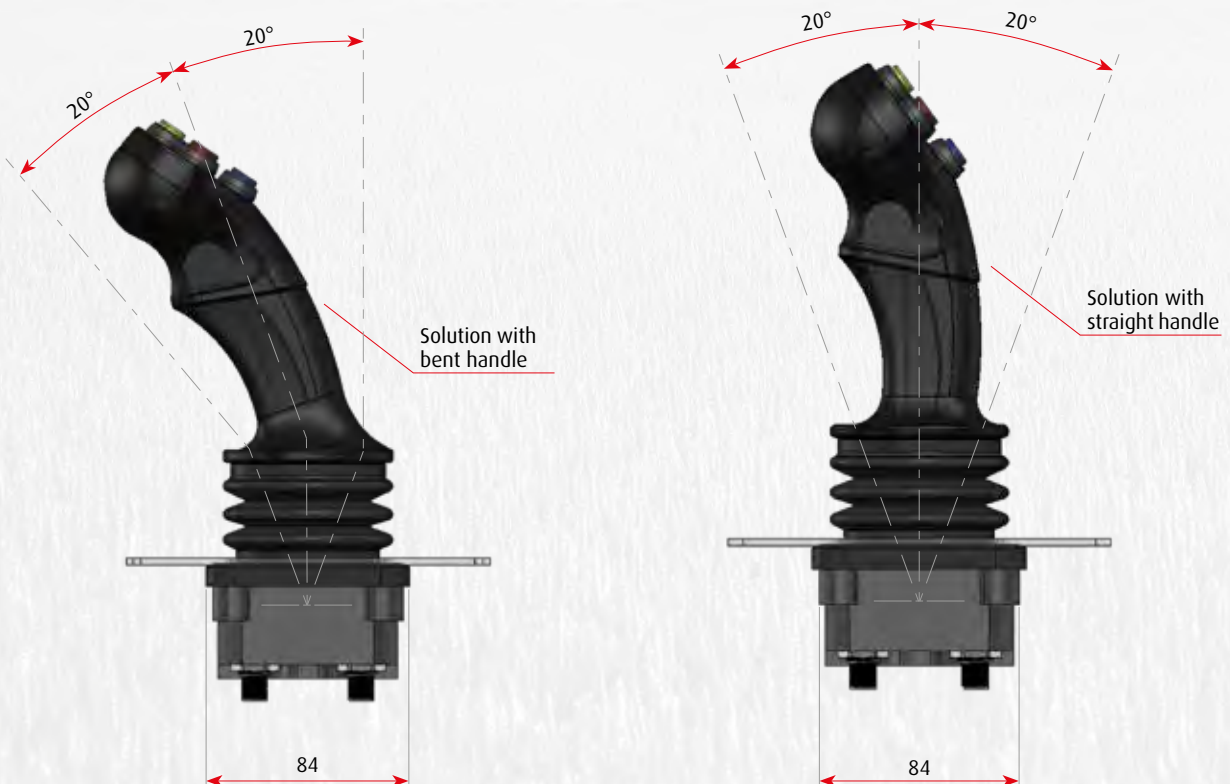

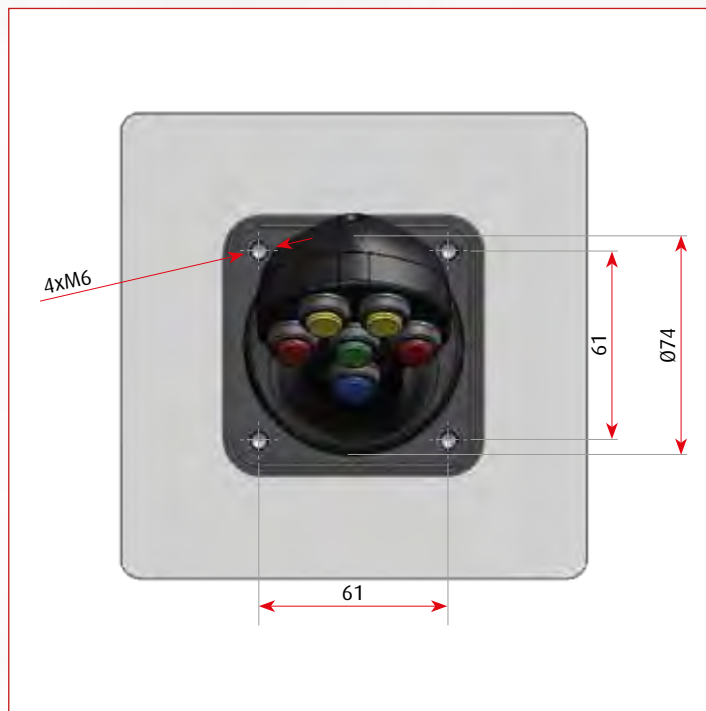
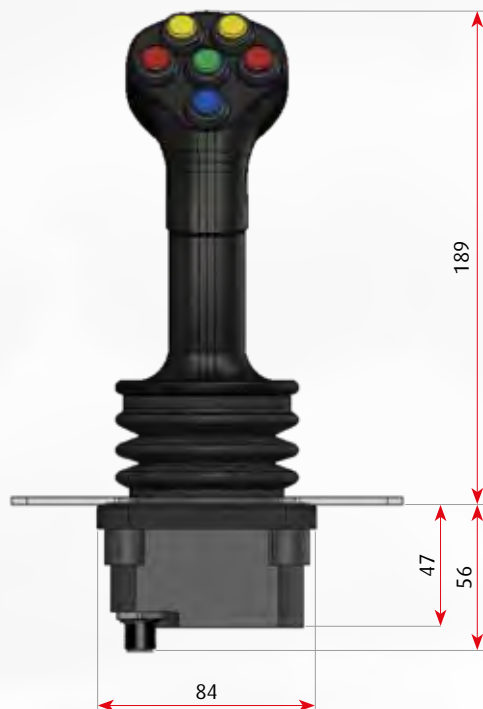

MECHANICAL SPECIFICATION	
• Operational life (at 25 °C)	1 million cycles
• Operating temperature	-40 .. + 80 °C
• Storing temperature	-40 .. + 110 °C
• Weight	0.75 kg
• Hysteresis	0.15% on read value
• Travel angle	+/- 20 degrees with respect to neutral position

ELECTRICAL SPECIFICATION (VERSION WITH 2 VOLTAGE CHANNELS)	
• Sensor	Hall effect
• Power supply	5 Vdc ±10% ratiometric
• Electrical signal	Galvanically insulated
• Resolution and update rate	10 bit, update rate 0.1 ms
• Correlation in case of 2 signals	Better than 1% in the whole pedal range
• Current consumption	<10 mA (per each channel)
• Minimum load resistance	4.7 kΩ
• Maximum load capacitance	10 nF

APPLICATION EXAMPLE: LEVER 610 WITH VOLTAGE OUTPUT

Here below are reported typical standard configurations of foot pedals with 1 channel, 2 channels voltage output and 1 channel voltage + 1 Idle Validation Switch. Output voltage profile is fully programmable at the factory.

INTERFACE CONFIGURATION	CODE	SIGNAL OUTPUT
• 1 channel	610.01.00	CH1 = voltage signal
• 2 channels	610.02.00	CH1 = voltage signal; CH2 = voltage signal
• 1 channel + 1 idle validation switch	610.03.00	CH1 = voltage signal; CH2 = IVS

For a complete overview of lever 610 and its available interfaces, please refer to the ECU interface section.

620

Electronic control lever

▼ Electronic control lever general purpose

This series of electronic control levers is suitable for a variety of applications, including industrial vehicles, agricultural machines, heavy duty and any other kind of special machines. Thanks to its robust mechanism, it can operate in harsh environments in continuous operation with high reliability and long working life.

It can be mounted only in cabin. It is equipped with a friction which can be tuned and with a neutral detent. A micro switch identifies the neutral position. Position is measured via potentiometer.

Cabling is through a terminal block positioned in the lower part of the lever.

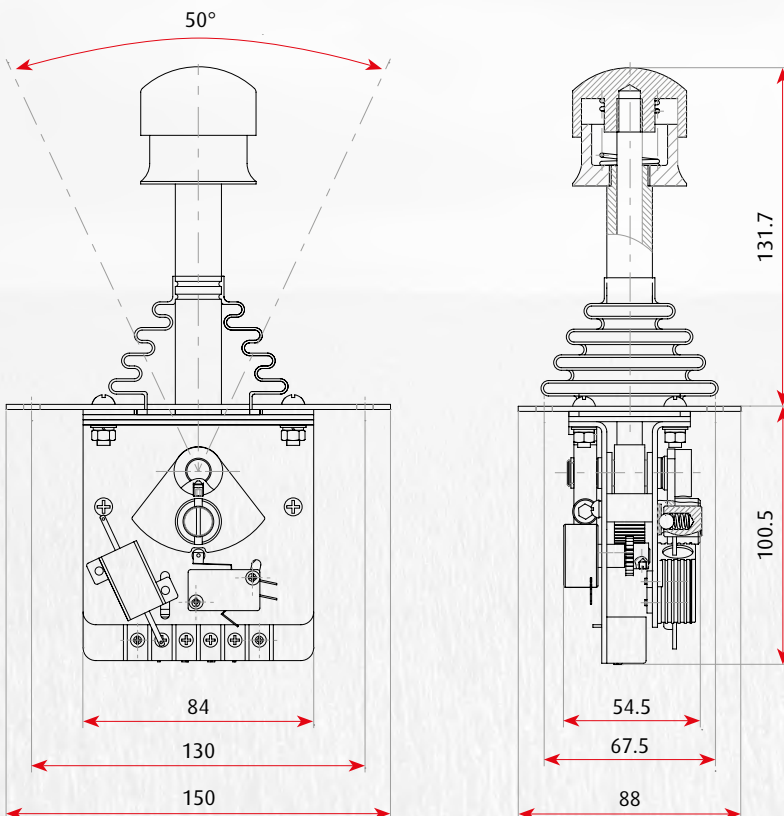

INTERFACE CONFIGURATION	CODE	SIGNAL OUTPUT
• 1 channel (potentiometer)	620.01.00	CH1 = voltage signal
• 1 channel + 1 neutral switch	620.03.00	CH1 = voltage signal; CH2 = neutral switch

630

Electronic control lever

Electronic control lever

This series of electronic control levers is suitable for a variety of applications, including industrial vehicles, agricultural machines, heavy duty and any other kind of special machines.

The die cast lever is simple, very robust and thanks to the non-contact sensor technology, it can operate in harsh environments in continuous operation with high reliability and long working life. It can be mounted either in the cabin or in open air. The sensorless technology guarantees a longer life time, if compared with a lever with potentiometer. Thanks to its different versions, 1 or 2 channels, with or without idle validation switch, PWM, current and CANBus, this lever can interface with almost all electronic motors.

Upon request lever 630 can be equipped with company logo. Electrical cable can also be configured in the desired length, number of poles, type of connector.

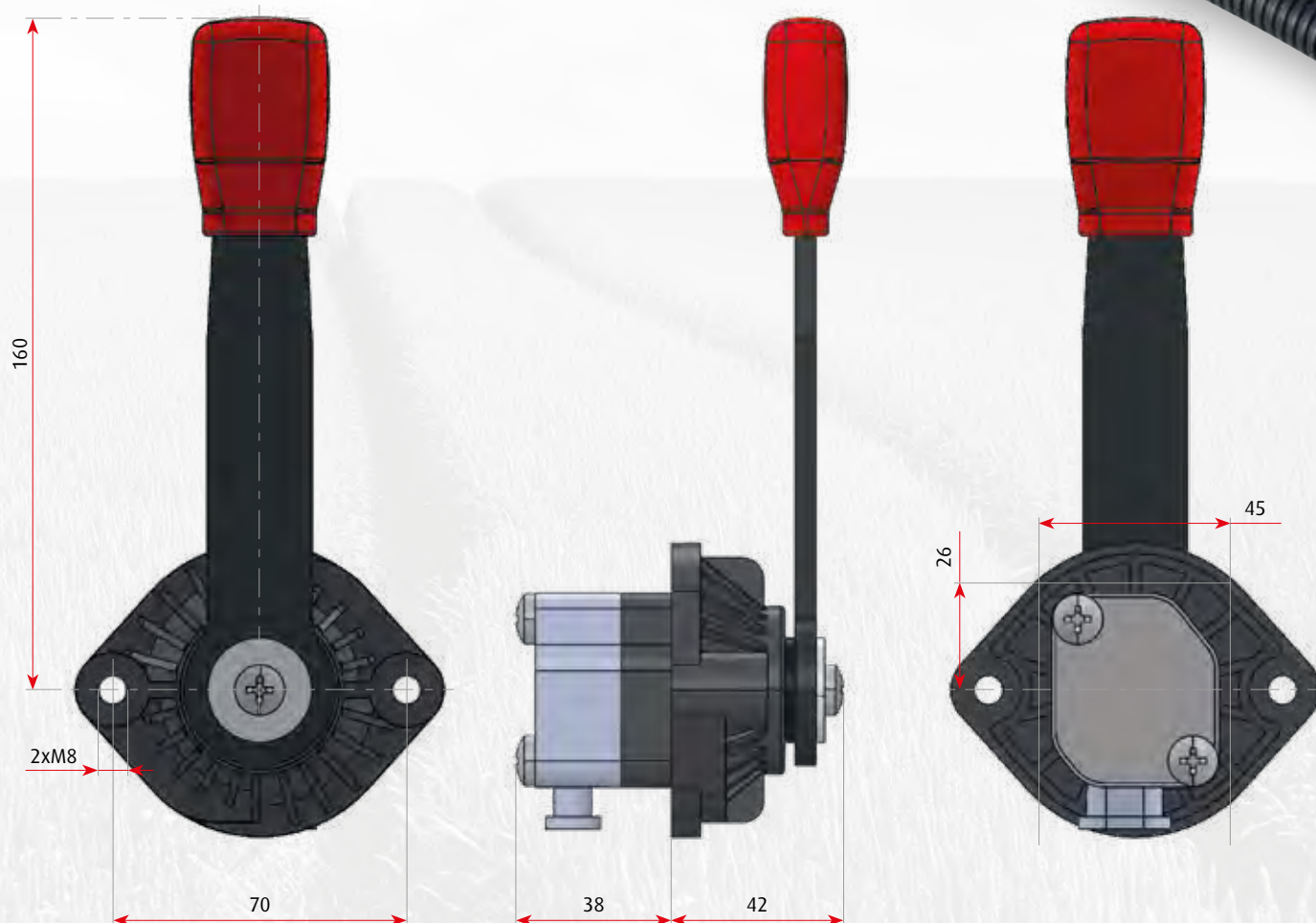

MECHANICAL SPECIFICATION	
• Operational life (at 25 °C)	10 million cycles
• Operating temperature	-40 °C .. +80 °C
• Storing temperature	-40 .. +110 °C
• Weight	0.50 kg
• Rotation	On bushes
• Mechanical friction	Adjustable
• Travel angle	60 degrees

ELECTRICAL SPECIFICATION (VERSION WITH VOLTAGE SIGNALS)	
• Sensor	Hall effect
• Electrical signal	Voltage output galvanically separated
• Kind of signal	Ratiometric
• Linearity	2%
• Accuracy	2%
• Power supply	5 V ±10%
• Current consumption	<10 mA (per each channel)
• Minimum load resistance	4.7 KΩ
• Maximum load capacitance	10 nF

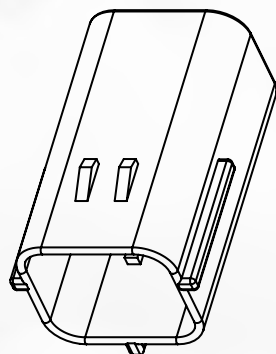

Front view (contacts side)

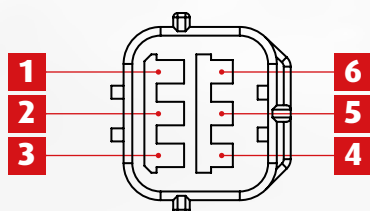

PINOUT WITH STANDARD CONNECTOR (TYCO ECONOSEAL J 6 VIEWS)

PIN	CH.1 = VOLTAGE SIGNAL CH.2 = VOLTAGE SIGNAL		CH.1 = VOLTAGE SIGNAL CH.2 = IVS	
	DESCRIPTION	COLOR	DESCRIPTION	COLOR
• 1	GND	Black	GND	Black
• 2	Ch.1 - Signal	Brown	Ch.1 - Signal	Brown
• 3	Ch.1 - Supply	Red	Ch.1 - Supply	Red
• 4	Ch.2 - Supply	Green	Ch.2 - Supply	Blue
• 5	Ch.2 - Signal	Blue	IVS - NO	Green
• 6	GND	Yellow	IVS - NA	Yellow

ELECTRONIC LEVER WITH VOLTAGE CHANNELS

Below are reported the typical standard configuration of control lever with 1 channel, 2 channels voltage output and 1 channel voltage + 1 Idle Validation Switch. Electrical cable standard length is 0.5 meter but any other length can be defined when ordering. Factory standard connector is AMP Metripack 6 poles but it can also be defined when ordering.

INTERFACE CONFIGURATION	CODE	SIGNAL OUTPUT
• 1 channel	.01.00	CH1 = voltage signal
• 2 channels	630.02.00	CH1 = voltage signal; CH2 = voltage signal
• 1 channel + 1 idle validation switch	630.03.00	CH1 = voltage signal; CH2 = IVS

For a complete overview of Lever 630 configured with different possible interfaces, please refer to section ECU Interfaces.

Electronic Pedals

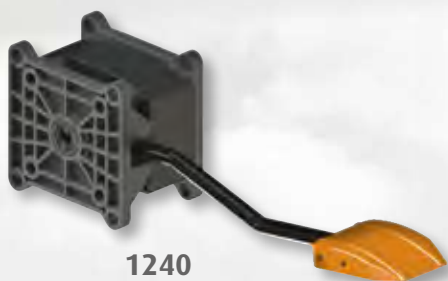

1240

Electronic throttle pedal

▼ General purpose throttle pedal

This series of pedals is mainly intended for tractors and agricultural equipment but, due to its versatile mounting features, it can be mounted on several kind of vehicles. A double concentric torsion spring is incorporated for idle position return.

Made in Nylon 6.1 plus GF, pedal 1240 is very robust and reliable. It is easy to customize and has a high mounting flexibility:

- Floor mounting
- Wall mounting
- Side mounting
- Under floor mounting

All “built in design” includes springs and electronic card. It is available with different IP protection degrees (from 00 to 69K). In line with automotive throttle pedal design, sensors are fully integrated into the housing.

Redundant system for “extreme” uses (e.g.: 4 channels output for mining applications).

Measuring position is through Hall effect sensor and up to 4 channels can be provided. It is available with any kind of electrical interface: voltage with or without idle validation switch, PWM, current, CANBus.

Upon request, pedal 1240 can be configured with the desired electrical cable length, number of poles, type of connector.

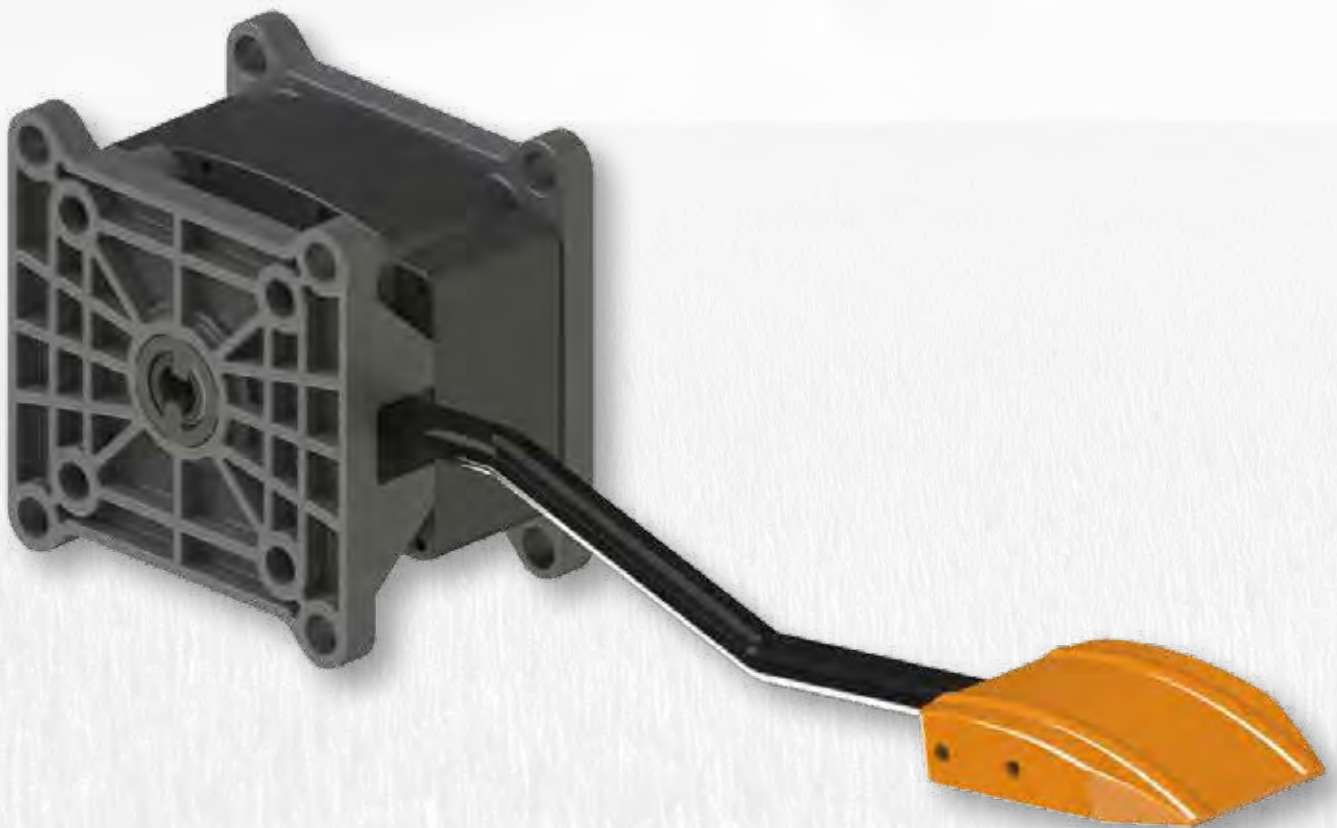

INSTALLATION EXAMPLES

Under floor mounting

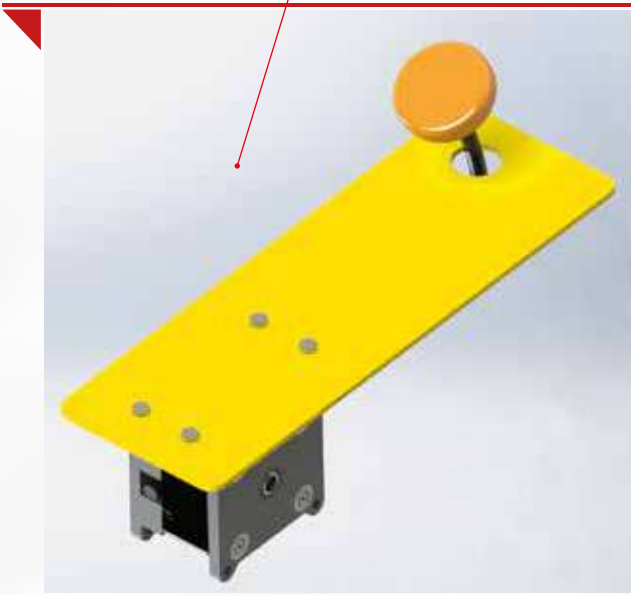

Floor mounting

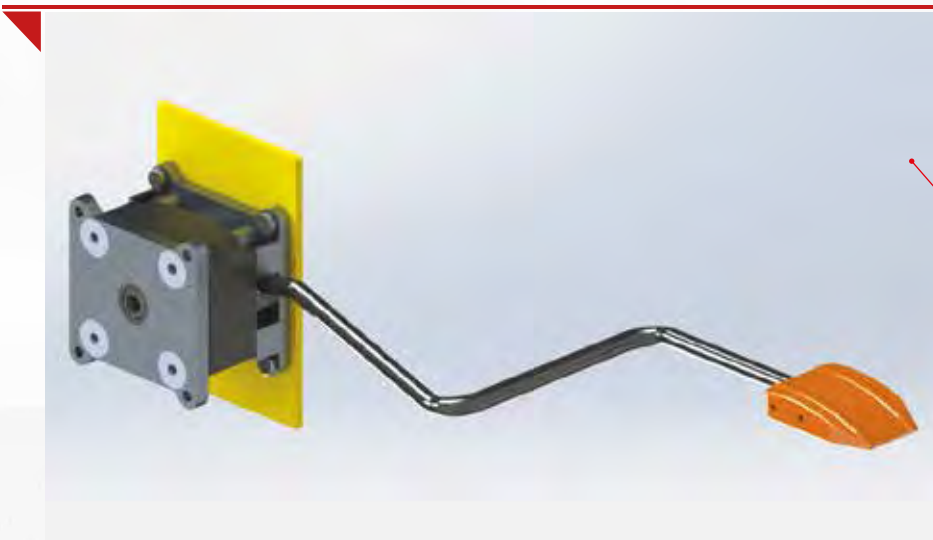

Side mounting

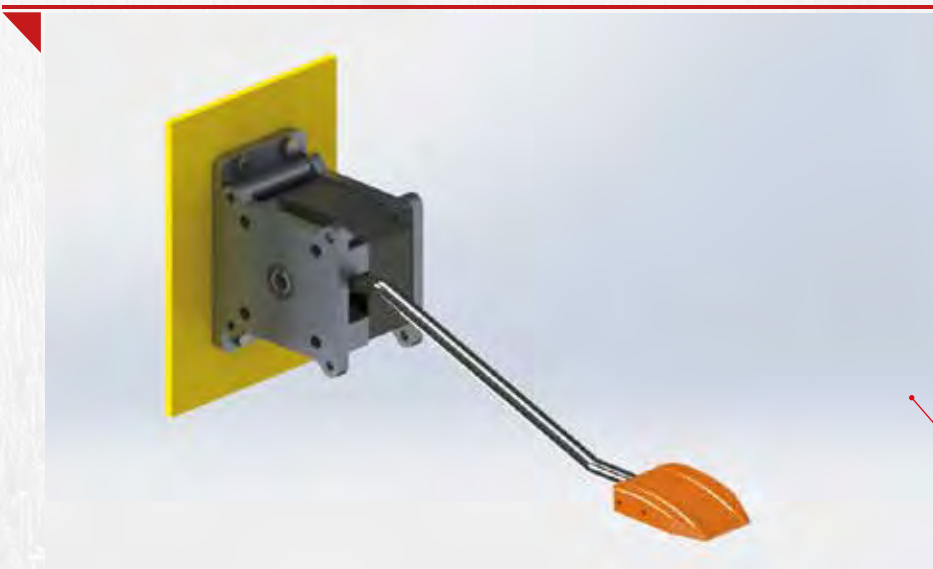

Wall mounting



PHYSICAL DIMENSIONS AND MOUNTING INSTRUCTIONS

PEDAL DIMENSION

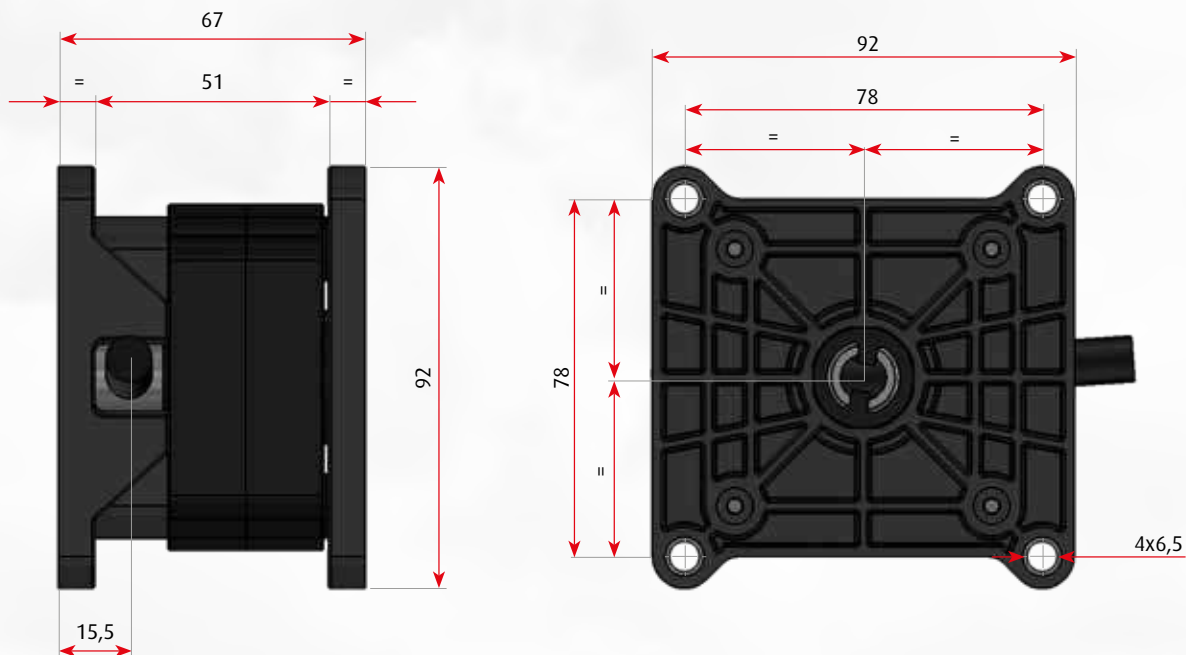

FIXING BRACKET

The fixing bracket is necessary in case of wall mounting, floor mounting and under the floor mounting. It is not necessary in case of side mounting.

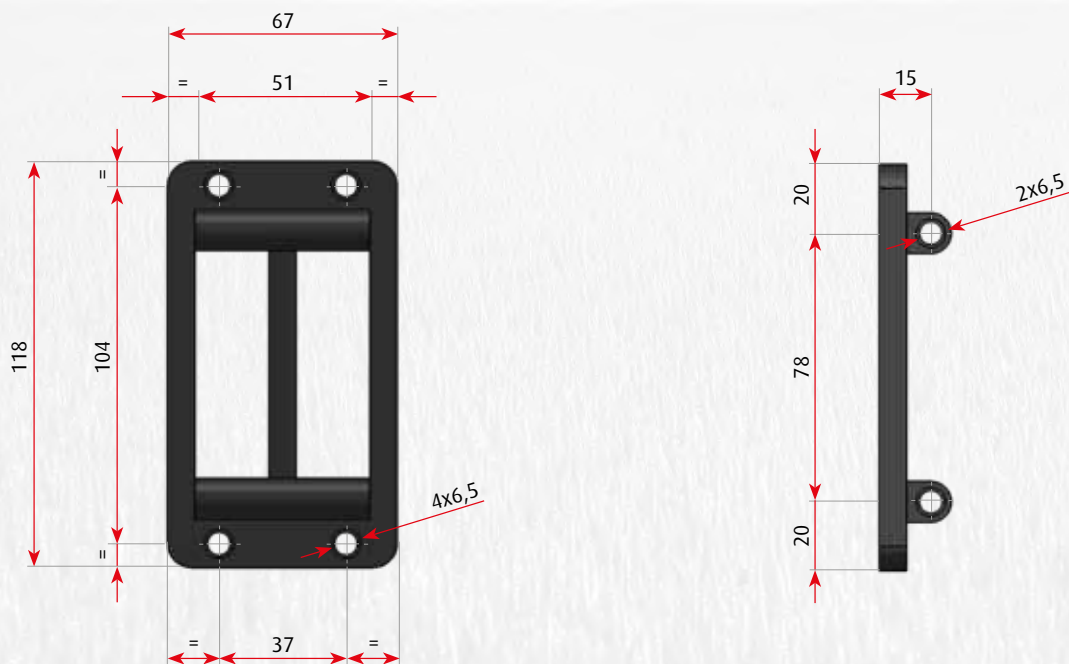

LIST CODE OF MOST COMMON ELECTRONIC PEDALS AND LEVERS

MECHANICAL SPECIFICATION	
• Operational life (at 25 °C)	10 million cycles
• Operating temperature	-40 .. +80 °C
• Storing temperature	-40 .. +110 °C
• Weight (without arm)	0.80 kg
• Return spring	Double safety spring
• Hysteresis	0.15% on read value
• Travel angle	22 degrees

ELECTRICAL SPECIFICATION (VERSION WITH VOLTAGE SIGNALS)	
• Sensor	Hall effect
• Power supply	5 Vdc ±10% ratio metric
• Electrical signal	Galvanically insulated
• Resolution and update rate	10 bit, update rate 0,1 ms
• Correlation in case of 2 signals	Better than 1% in the whole pedal range
• Current consumption	<10 mA (per each channel)
• Minimum load resistance	4.7 kΩ
• Maximum load capacitance	10 nF

APPLICATION EXAMPLE:

PEDAL 1240 WITH 2 VOLTAGE OUTPUT

Here below are reported typical standard configurations of foot pedals with 1 channel, 2 channels voltage output and 1 channel voltage + 1 Idle Validation Switch. Electrical cable standard length is 0,5 meter but any other length can be defined when ordering. Factory standard connector is AMP Superseal 6 poles but any other connector can be defined when ordering.

INTERFACE CONFIGURATION	CODE	SIGNAL OUTPUT
• 1 channel	1240.01.00	CH1 = voltage signal
• 2 channels	1240.02.00	CH1 = voltage signal; CH2 = voltage signal
• 1 channel + 1 idle validation switch	1240.03.00	CH1 = voltage signal; CH2 = IVS

For a complete overview of Pedal 1240 configured with other types of signal, please refer to ECU interfaces section.

1252

Electronic throttle pedal

This series of aluminium die cast floor mounted pedals is indicated for medium and heavy duty applications

It is a more economic version of pedal series 1250 but it has all the performances and functionalities of the previous series. It is interchangeable with the most common electronic throttle pedal available in the market. The sensor-less technology guarantees a very long life time.

It is available in several versions: 1 or 2 voltage channels, with or without idle validation switch, PWM, current, CANBus. Thanks to an innovative mechanical hysteresis device, it is possible to tune the pedal to any kind of environment, adapting the damping of vibrations which vary from a very smooth to a very rough terrain. Kick-down function is also available.

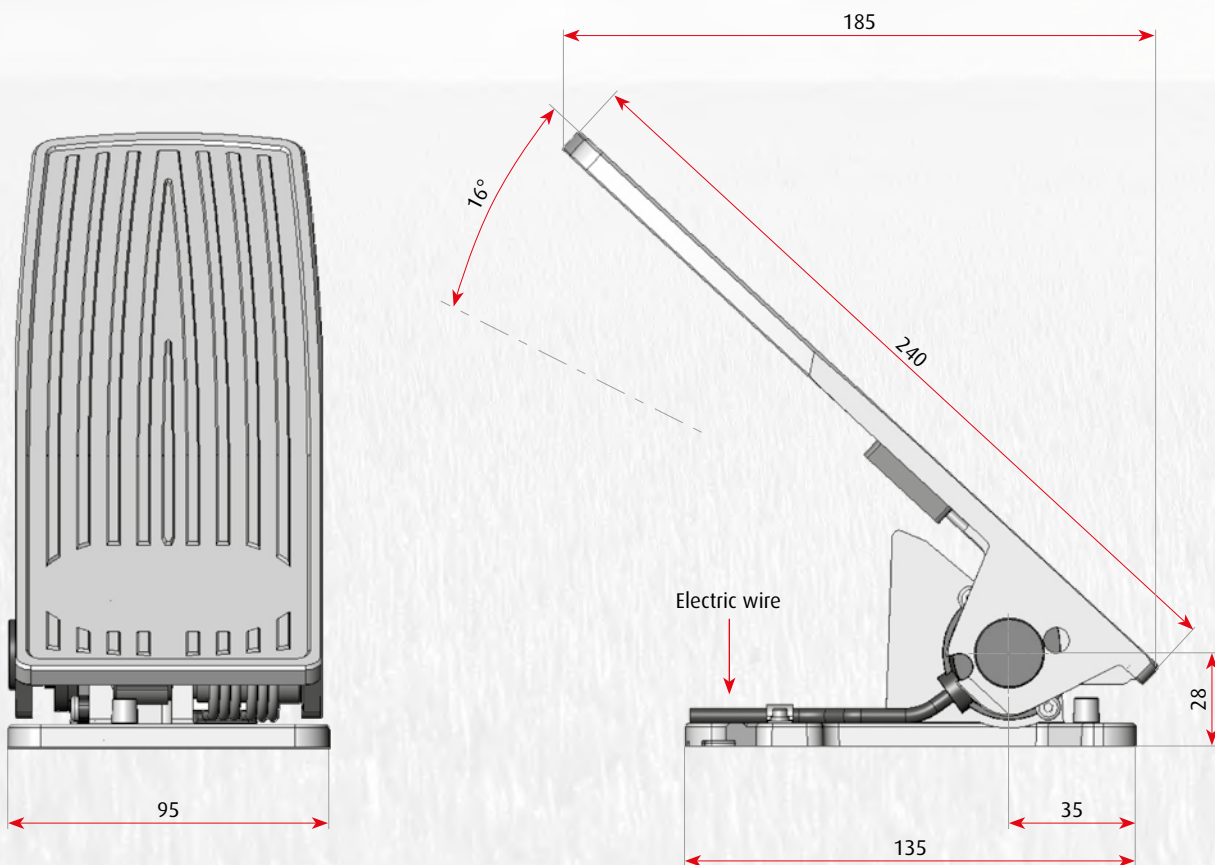

PHYSICAL DIMENSIONS AND MOUNTING INSTRUCTIONS

The mechanical hysteresis can be adjusted via the hexagonal screw placed on the right side of the pedal (front view), as shown in the above picture.

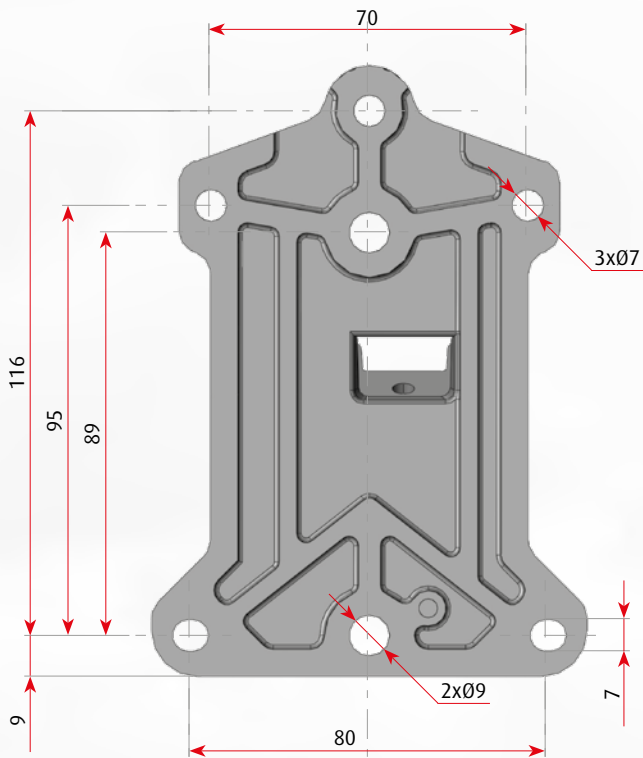

Hysteresis range: 0 ÷ 0.7 Nm



MECHANICAL SPECIFICATION

• Operational life (at 25 °C)	20 million cycles
• Operating temperature	-40 .. +90 °C
• Storing temperature	-40 .. +110 °C
• Weight	0.90 kg
• Return spring construction	Double safety spring
• Mechanical hysteresis	Adjustable
• Travel angle	18 degrees

ELECTRICAL SPECIFICATION (VERSION WITH 2 VOLTAGE CHANNELS)

• Sensor	Hall effect
• Power supply	5 Vdc ±10% ratio metric
• Electrical signal	Galvanically insulated
• Resolution and update rate	10 bit, update rate 0.1 ms
• Linearity	better than 1%
• Correlation in case of 2 signals	better than 2%
• Current consumption	<10 mA (per each channel)
• Minimum load resistance	4.7 kΩ
• Maximum load capacitance	10 nF

APPLICATION EXAMPLE:

PEDAL 1252 WITH 2 VOLTAGE CHANNELS

Here below are reported typical standard configurations of throttle pedals with 1 channel, 2 channels voltage output and 1 channel voltage + 1 Idle Validation Switch. Electrical cable standard length is 0,5 meter but any other length can be defined when ordering. Factory standard connector is AMP Metripack 6 poles but any other connector can be defined when ordering.

INTERFACE CONFIGURATION	CODE	SIGNAL OUTPUT
• 1 channel	1252.01.00	CH1 = voltage signal
• 2 channels	1252.02.00	CH1 = voltage signal; CH2 = voltage signal
• 1 channel + 1 idle validation switch	1252.03.00	CH1 = voltage signal; CH2 = IVS

For a complete overview of Pedal 1252 configured with different possible interfaces, please refer to the section ECU Interfaces.

1260 and 1262 Electronic throttle pedal

▼ Electronic throttle pedal

Aluminium throttle pedal floor or wall mountable. This series of pedals is intended for any kind of vehicles. A triple torsion spring is incorporated for idle position return.

The frame of this series of pedals is made of aluminum; paddle of 1260 is in aluminum and paddle of 1626 is in plastic. They can be either floor or wall mounted. The electronic circuit is fully protected against water and any kind of contaminants. Thanks to its particular enclosure, a high IP is guaranteed and environmental contamination is minimized.

Measuring position is through Hall effect sensor with one or two channels. It is available with any kind of electrical interface: 1 or 2 voltage channels, with or without idle validation switch, PWM, current, CANBus.

Upon request, they can be configured with the desired electrical cable length, number of poles, type of connector.



PHYSICAL DIMENSIONS AND MOUNTING INSTRUCTIONS

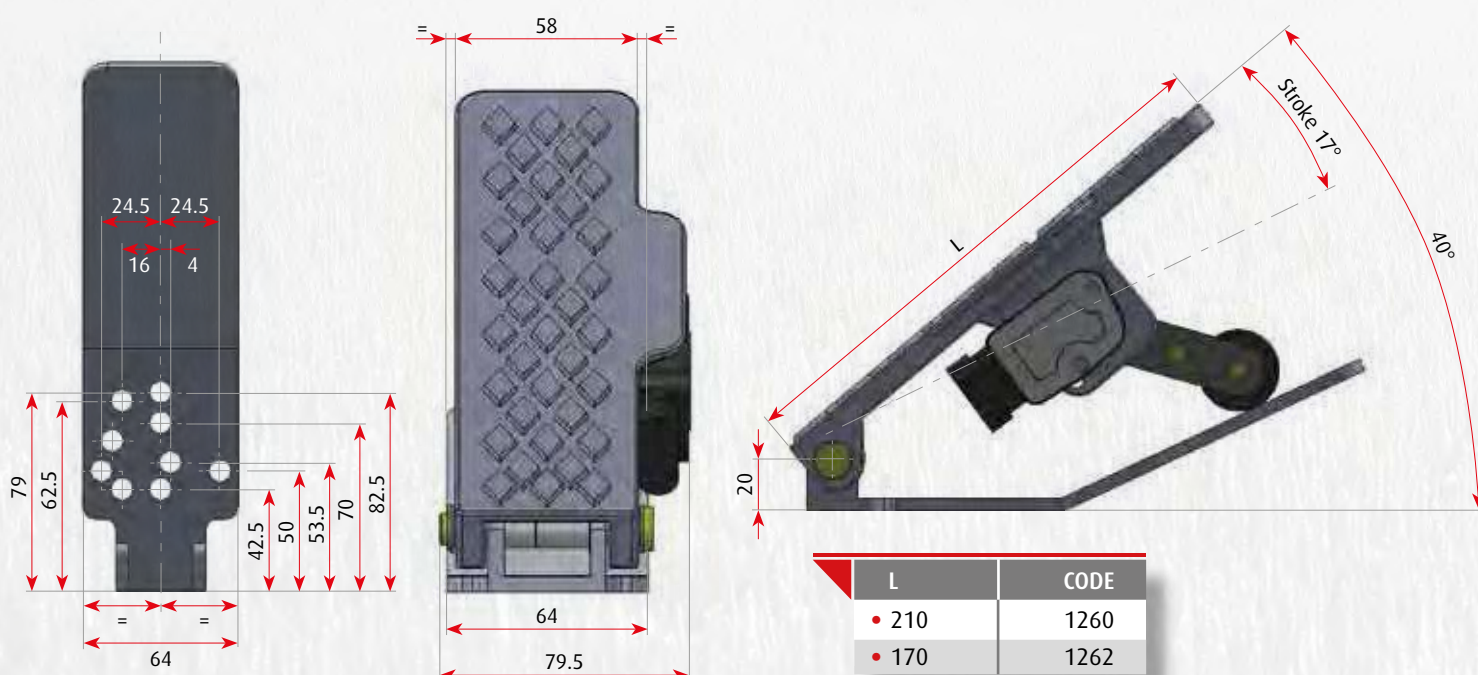

MECHANICAL SPECIFICATION

• Operational life (at 25 °C)	5 million cycles
• Operating temperature	-40 .. + 80 °C
• Storing temperature	-40 .. +110 °C
• Weight	1.20 kg
• Return spring	Double safety spring
• Spring torque at idle	2.5 Nm
• Spring torque at WOT	4.5 Nm
• Hysteresis	0.15% on read value
• Travel angle	17 degrees

ELECTRICAL SPECIFICATION (VERSION WITH VOLTAGE SIGNALS)

• Sensor	Hall effect
• Power supply	5 Vdc ±10% ratio metric
• Electrical signal	Galvanically insulated
• Resolution and update rate	10 bit, update rate 0.1 ms
• Correlation in case of 2 signals	better than 1% in the whole pedal range
• Current consumption	<10 mA (per each channel)
• Minimum load resistance	4.7 kΩ
• Maximum load capacitance	10 nF

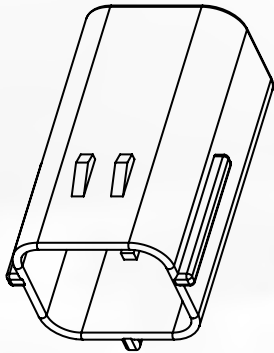

Front view (contacts side)

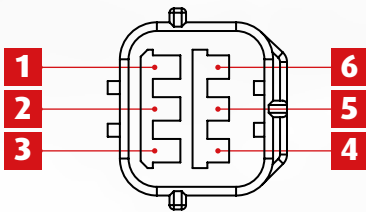

PINOUT WITH STANDARD CONNECTOR (TYCO ECONOSEAL J 6 VIEWS)

PIN	CH.1 = VOLTAGE SIGNAL CH.2 = VOLTAGE SIGNAL		CH.1 = VOLTAGE SIGNAL CH.2 = IVS	
	DESCRIPTION	COLOR	DESCRIPTION	COLOR
• 1	GND	Black	GND	Black
• 2	Ch.1 - Signal	Brown	Ch.1 - Signal	Brown
• 3	Ch.1 - Supply	Red	Ch.1 - Supply	Red
• 4	Ch.2 - Supply	Green	IVS - COM	Blue
• 5	Ch.2 - Signal	Blue	IVS - NO	Green
• 6	GND	Yellow	IVS - NC	Yellow

APPLICATION EXAMPLE:

PEDAL 1260 WITH 2 VOLTAGE OUTPUT

Here below are reported typical standard configurations of foot pedals with 1 channel, 2 channels voltage output and 1 channel voltage + 1 Idle Validation Switch. Electrical cable standard length is 0.5 meter but any other length can be defined when ordering. Factory standard connector is AMP 6 poles but any other connector can be defined when ordering.

INTERFACE CONFIGURATION	CODE	SIGNAL OUTPUT
• 1 channel	1260.01.00	CH1 = voltage signal
• 2 channels	1260.02.00	CH1 = voltage signal; CH2 = voltage signal
• 1 channel + 1 idle validation switch	1260.03.00	CH1 = voltage signal; CH2 = IVS
• 1 channel	1262.01.00	CH1 = voltage signal
• 2 channels	1262.02.00	CH1 = voltage signal; CH2 = voltage signal
• 1 channel + 1 idle validation switch	1262.03.00	CH1 = voltage signal; CH2 = IVS

For the complete of the signal, please refer to ECU interfaces section.

1270

Electronic throttle pedal

▼ This series of plastic wall mounted pedals is intended for any kind of vehicles

A triple concentric torsion spring is incorporated for idle position return.

Made of polyarylamide (PAA) reinforced with 60% fibreglass, pedal 1270 is very robust and reliable, therefore it can be mounted also on heavy duty construction machines or military vehicles.

Environmental contamination is minimised thanks to the joint combination of the gasket with the mounting flange which segregate the cabin from the engine area. The full sealing between the cabin and the engine area is widely appreciated in the military sector where the vehicles are specified to travel with the cabin up to one meter below the water level.

Measuring position is through Hall effect sensor with one or two channels. It is available with any kind of electrical interface: 1 or 2 voltage channels, with or without idle validation switch, PWM, current, CANBus.

Upon request, pedal 1270 can be equipped with the kick-down option and can be configured with the desired electrical cable length, number of poles, type of connector.



PHYSICAL DIMENSIONS AND MOUNTING INSTRUCTIONS

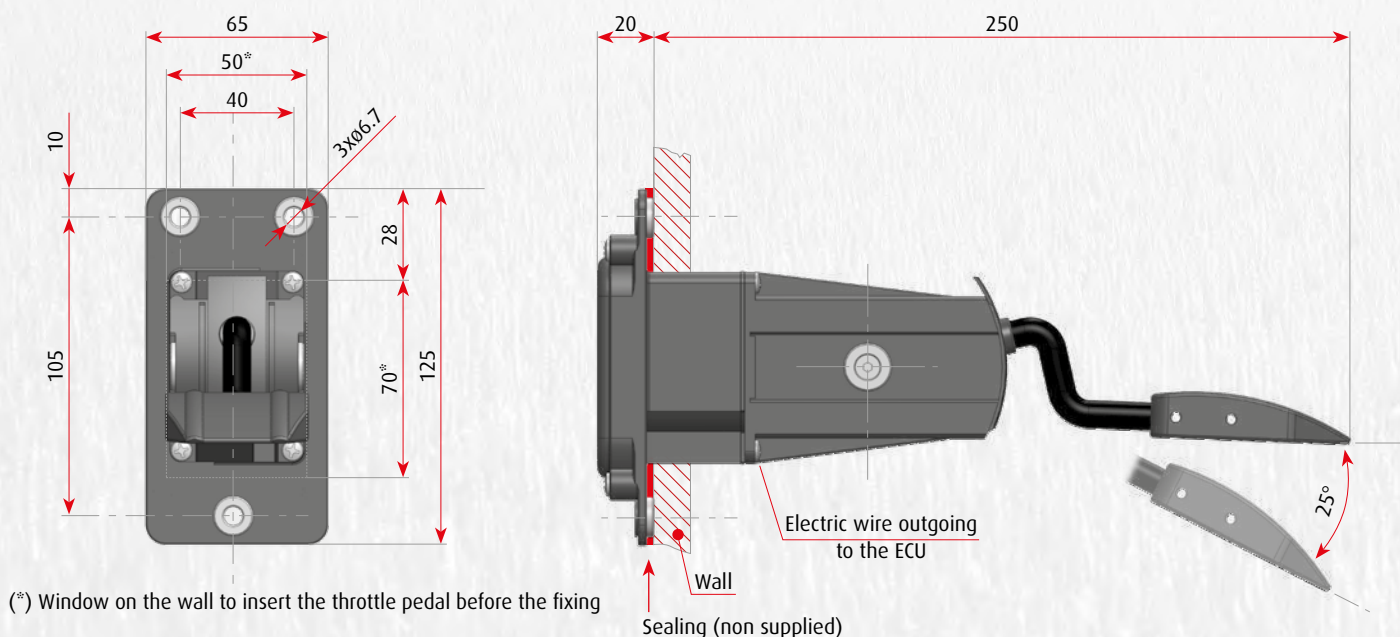



MECHANICAL SPECIFICATION

• Operational life (at 25 °C)	2 million cycles
• Operating temperature	-40 .. +80 °C
• Storing temperature	-40 .. +110 °C
• Weight	0.70 kg
• Return spring	Triple safety spring
• Hysteresis	0.15% on read value
• Travel angle	25 degrees

ELECTRICAL SPECIFICATION (VERSION WITH VOLTAGE SIGNALS)

• Sensor	Hall effect
• Power supply	5 Vdc ±10% ratio metric
• Electrical signal	Galvanically insulated
• Resolution and update rate	10 bit, update rate 0.1 ms
• Correlation in case of 2 signals	better than 1% in the whole pedal range
• Current consumption	<10 mA (per each channel)
• Minimum load resistance	4.7 kΩ
• Maximum load capacitance	10 nF

APPLICATION EXAMPLE: PEDAL 1270 WITH 2 VOLTAGE CHANNELS

Below are reported the typical standard configurations of throttle pedals with 1 channel, 2 channels voltage output and 1 channel voltage + 1 Idle Validation Switch. Electrical cable standard length is 0.5 meter but any other length can be defined when ordering. Factory standard connector is AMP Metripack 6 poles but any other connector can be defined when ordering.

INTERFACE CONFIGURATION

- 1 channel
- 2 channels
- 1 channel + 1 idle validation switch

CODE

1270.01.00
1270.02.00
1270.03.00

SIGNAL OUTPUT

CH1 = voltage signal
CH1 = voltage signal; CH2 = voltage signal
CH1 = voltage signal; CH2 = IVS

For a complete overview of Pedal 1270 configured with different possible interfaces, please refer to ECU interfaces section.

1280

Electronic throttle pedal

▼ This series of plastic floor mounted pedals is intended for any kind of vehicles

A double concentric torsion spring is incorporated for idle position return. Made of polyamide PA66 reinforced with 30% fibreglass, pedal 1280 is very robust and reliable, therefore it can be mounted also on heavy duty construction machines, agriculture machinery or military vehicles.

The electronic circuit is fully protected against water and any kind of contaminants. Thanks to its particular enclosure, a high IP is guarantee for the whole pedal and environmental contamination is minimized.

Measuring position is through Hall effect sensor with one or two channels. It is available with any kind of electrical interface: 1 or 2 voltage channels, with or without idle validation switch, PWM, current, CANBus. In order to adapt to the most ergonomic position, the paddle can be adjust to different angles (A=): 27°, 36° and 45°.

Upon request, pedal 1280 can be equipped with the kick-down option and can be configured with the desired electrical cable length, number of poles, type of connector.

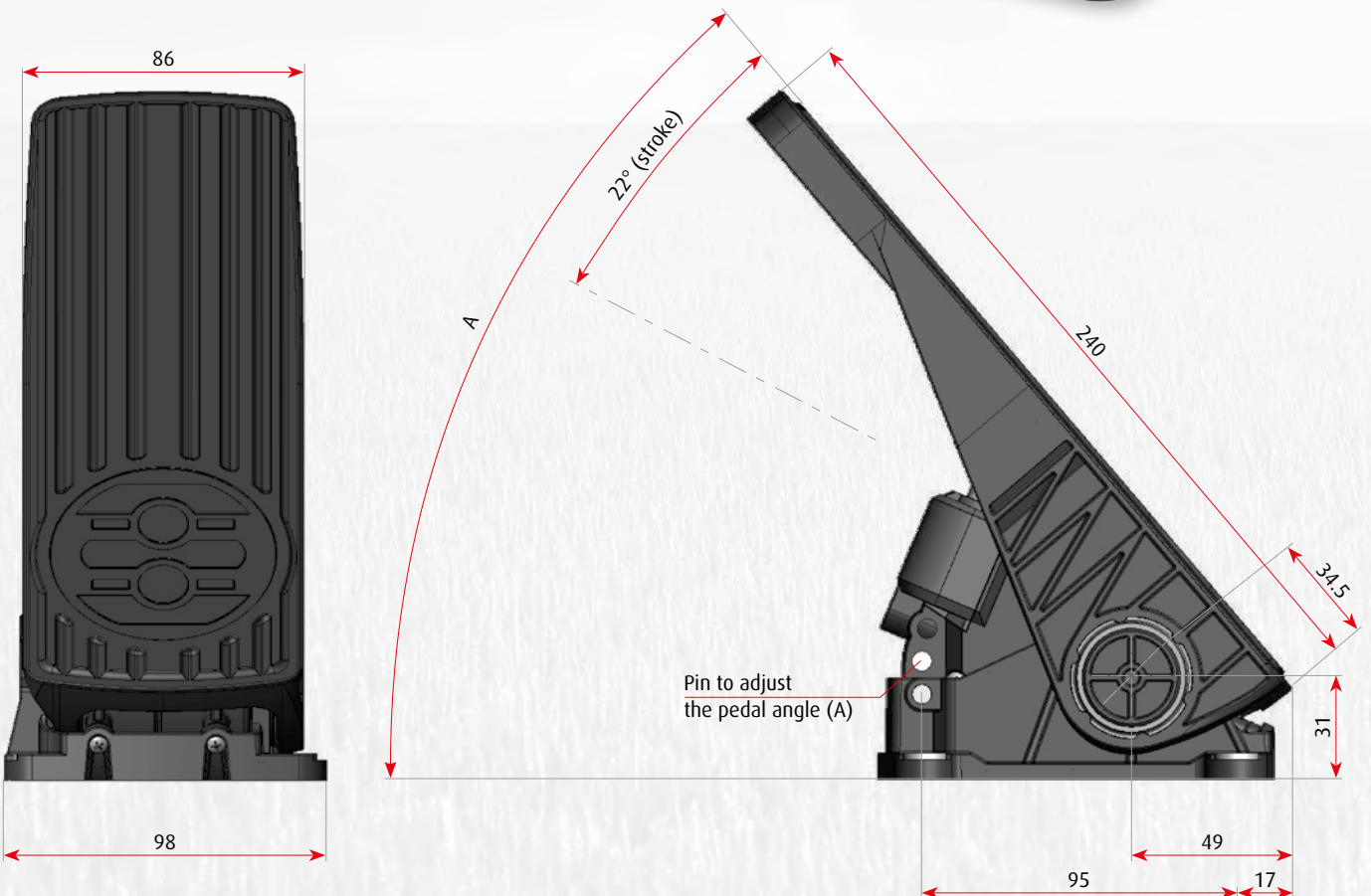

PHYSICAL DIMENSIONS AND MOUNTING INSTRUCTIONS

Adjust the friction of mechanical hysteresis with an hexagonal key of 4 mm. The access is from the bottom of the pedal.

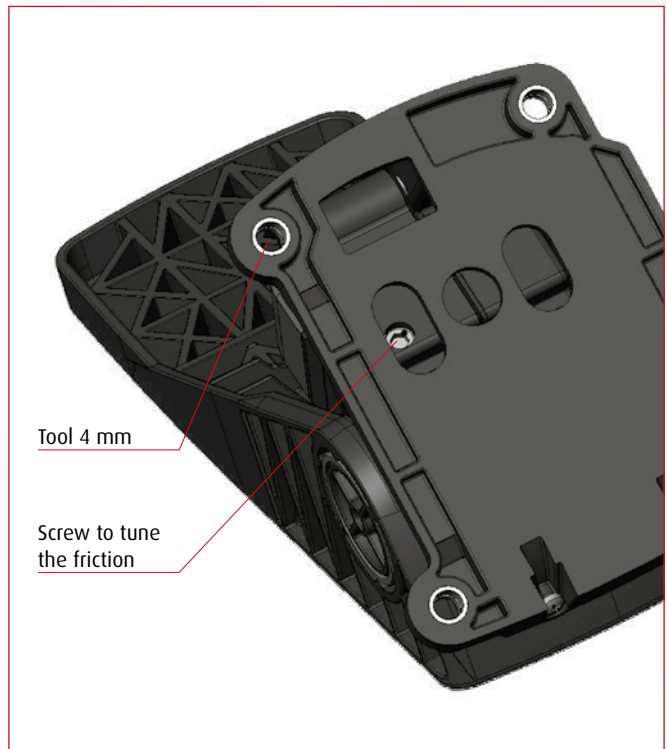
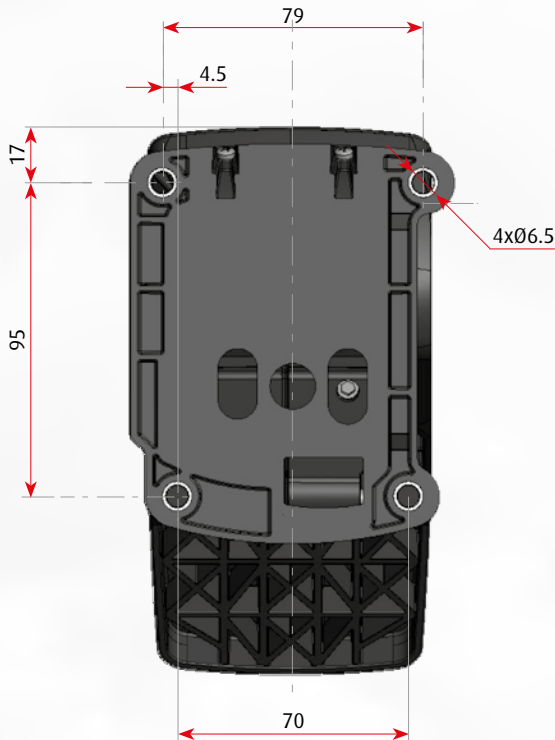

MECHANICAL SPECIFICATION

• Operational life (at 25 °C)	10 million cycles
• Operating temperature	-40 .. +80 °C
• Storing temperature	-40 .. +110 °C
• Weight	0.80 kg
• Return spring	Double safety spring
• Hysteresis	0.15% on read value
• Travel angle	22 degrees

ELECTRICAL SPECIFICATION (VERSION WITH VOLTAGE SIGNALS)

• Sensor	Hall effect
• Power supply	5 Vdc ±10% ratio metric
• Electrical signal	Galvanically insulated
• Resolution and update rate	10 bit, update rate 0.1 ms
• Correlation in case of 2 signals	better than 1% in the whole pedal range
• Current consumption	<10 mA (per each channel)
• Minimum load resistance	4.7 kΩ
• Maximum load capacitance	10 nF

APPLICATION EXAMPLE: PEDAL 1280 WITH 2 VOLTAGE CHANNELS

Here below are reported typical standard configurations of throttle pedals with 1 channel, 2 channels voltage output and 1 channel voltage + 1 Idle Validation Switch. Electrical cable standard length is 0,5 meter but any other length can be defined when ordering. Factory standard connector is AMP Superseal 6 poles but any other connector can be defined when ordering.

INTERFACE CONFIGURATION	CODE	SIGNAL OUTPUT
• 1 channel	1280.01.00	CH1 = voltage signal
• 2 channels	1280.02.00	CH1 = voltage signal; CH2 = voltage signal
• 1 channel + 1 idle validation switch	1280.03.00	CH1 = voltage signal; CH2 = IVS

For a complete overview of Pedal 1280 configured with different possible interfaces, please refer to next section.



Mechatronic controls

4

These levers or systems combine electrical and mechanical commands co-ordinated via electronic and computing logic. These products can be customized, therefore if they might be of some interest for your application, please feel free to contact us or a Flexball's representative



LEVER 1300

This series of mechatronic controls is used to command the hydraulic pump for the motion of the machine. The lever combines a voltage output, generated from a Hall effect sensor, with a mechanical push-pull cable. A wide

range of sticks with different bending and lengths fulfil most of the application requirements. On the handle can be mounted up to 3 push buttons, a rocker or a miniature electrical joystick.



SPECIFICATION

- Lever ratio: 11:1
- Mechanical angle: ± 25 degrees
- Mechanical stroke of the push-pull cable: 50 mm
- Voltage output signal
 - 0.50 V in forward position
 - 2.25 V in neutral position
 - 4.50 V in reverse position
- Standard connector: 3 poles wire Deutsch DT

SYSTEM 1350

1350 is an automatic control system which provides significant fuel and wear reduction on excavators, backhoe and wheel loaders.

SYSTEM SETUP

It is basically composed of:

- Control lever 600 or on-off switches to define engine working speed
- Mechanical actuator to change the working speed as a consequence of the pressure needed in the hydraulic circuit
- Push-pull cable
- Cabling with electrical connection towards pressure transmitters
- Pressure transmitters
- Keypad for the setup programming

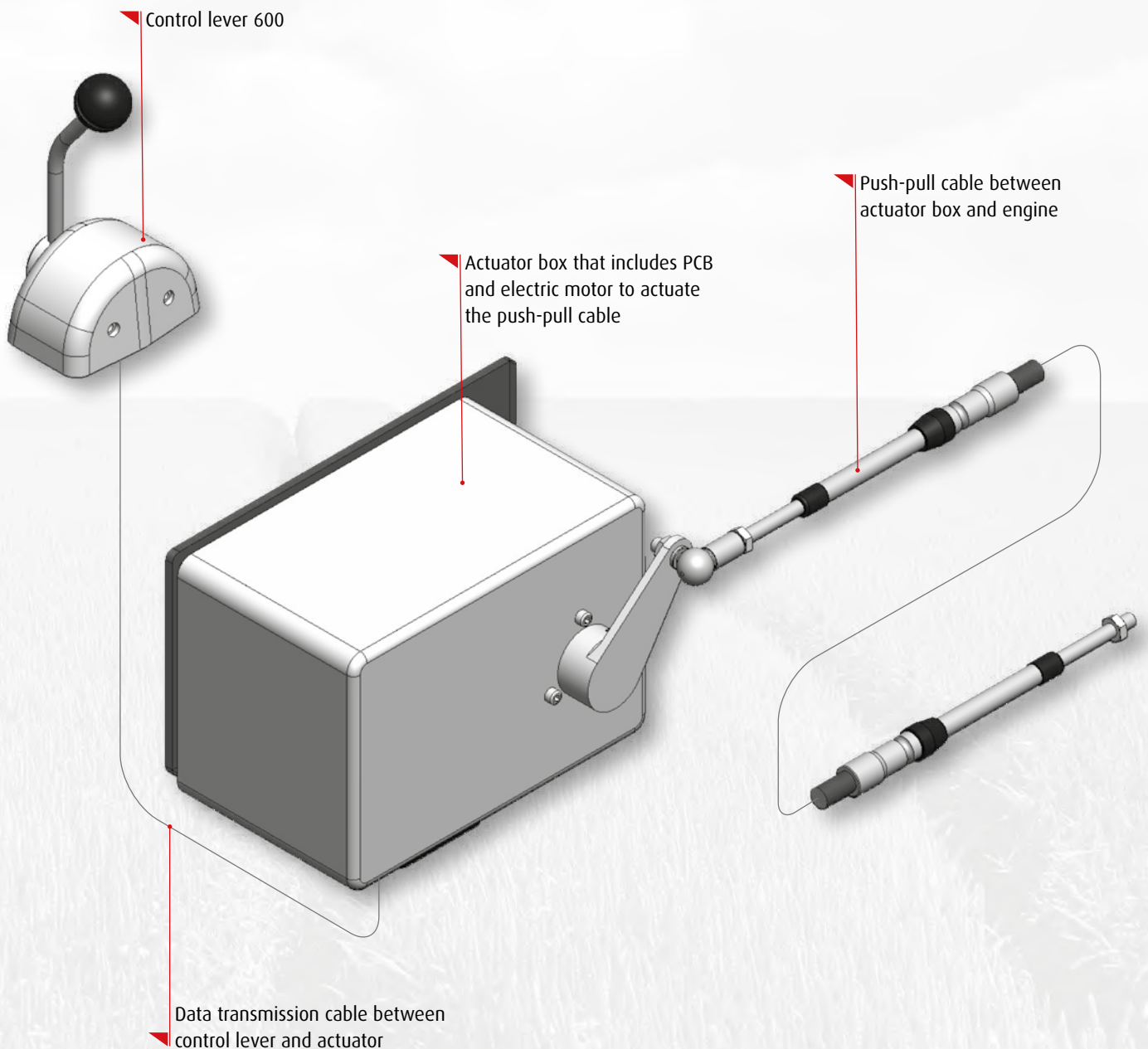

AN ENERGY SAVER AND ENVIRONMENTAL FRIENDLY DEVICE

The machine is usually set at its nominal speed, in order to generate the hydraulic power necessary to fulfil the most energy consuming operation. Most of the time however, the hydraulic circuit is generating more power than necessary and the excess of power is uselessly dissipated.

If we consider how it works an excavator, the operator is selecting a fixed number of RPMs, which will not be changed for the whole working day, independently if the machine is standstill or digging. The power required in the two operating modes is different and the result is a loss of energy all the times the excavator is not digging.

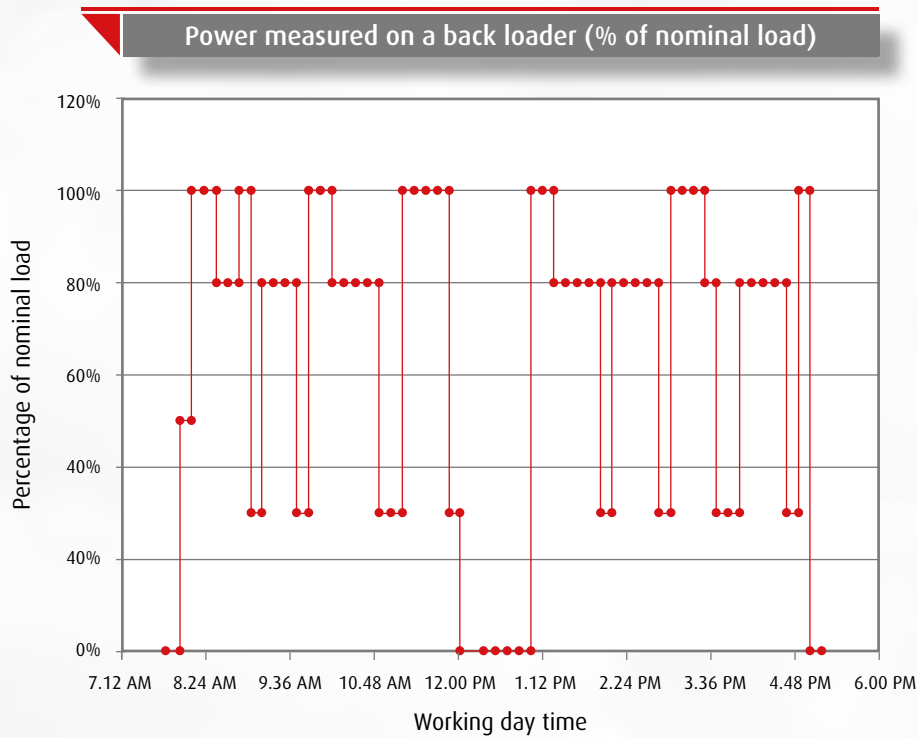

Field tests have demonstrated that installing in your machine the 1350 system, there is a saving of 3 litres of fuel per day in case of back loaders and up to 2.5 litres per hour in case of a 20 tons excavators.

The installation of system 1350 on a small size backhoe ensures a payback period within 6 months.

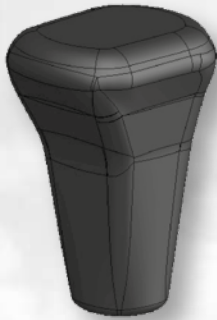

1705

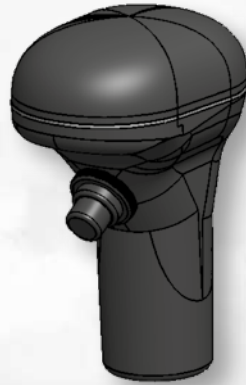

1710



1715



1720



1725



1730

Handles

TYPE OF HANDLE

1705 – STANDARD KNOB



IT CAN BE MOUNTED ON:

- Lever E95
- Lever 1068
- Joystick 2000
- Joystick 2500

1710 – ANATOMIC HANDLE

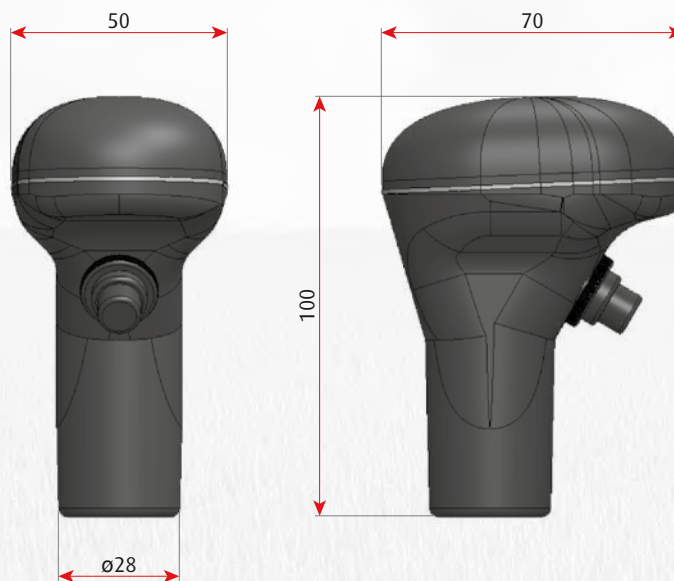

SPECIFICATION:

- Protection degree: IP65
- Max current/voltage rating with resistive load: 2A at 250 V_{ac} or 4A at 125 V_{ac}
- Electrical life: 10,000 cycles at full load

IT CAN BE MOUNTED ON:

- Lever 1068
- Joystick 2000
- Joystick 2500
- Joystick 2800
- Joystick 2900

1715 - REAR

Features

- Material: PA6+20% GF
- Marking available on the top

IT CAN BE MOUNTED ON:

- Joystick 2000
- Joystick 2500
- Joystick 2800
- Joystick 2900

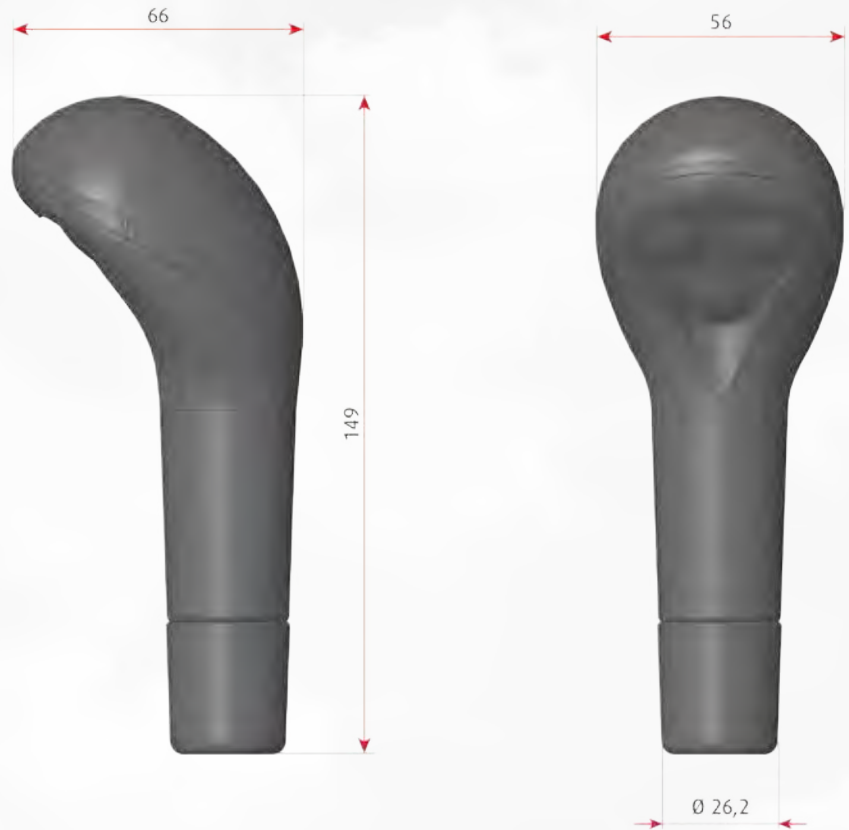

1720 - REAR

Features

- Material: PA6+20% GF, black
- Marking available on the top
- Available also in grey (code 1721)

IT CAN BE MOUNTED ON:

- Joystick 2000
- Joystick 2500
- Joystick 2800
- Joystick 2900



1725 – ERGONOMIC

Features

- Material: PA6+20% GF
- Protection: IP50 or IP67

IT CAN BE MOUNTED ON:

- Joystick 2000
- Joystick 2500
- Joystick 2800
- Joystick 2900
- Electronic joystick 700



1730 – ERGONOMIC XL

Features





- Material: PA6+20% GF
- Protection: IP50 or IP67





IT CAN BE MOUNTED ON:

- Joystick 2000
- Joystick 2500
- Joystick 2800
- Joystick 2900
- Electronic joystick 700

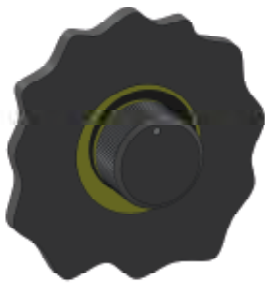

SWITCHES AND OTHER COMPONENTS

PUSH BUTTON	<p>A</p> <p>MOMENTARY PUSH-BUTTON, LOW CURRENT ROUND HEAD</p> <p>Protection: IP67 Rating current: 400 mA Voltage: 30 VDC</p>	
	<p>B</p> <p>MOMENTARY PUSH-BUTTON, LOW CURRENT FLAT HEAD</p> <p>Protection: IP67 Rating current: 400 mA Voltage: 30 VDC</p>	
	<p>C</p> <p>MOMENTARY PUSH-BUTTON, LOW CURRENT ROUND HEAD WITH LED</p> <p>Protection: IP67 Rating current: 400 mA Voltage: 30 VDC green (available also in blue)</p>	
	<p>D</p> <p>LATCHING PUSH-BUTTON, LOW CURRENT ROUND HEAD</p> <p>Protection: IP67 Rating current: 400 mA Voltage: 30 VDC</p>	
	<p>E</p> <p>MOMENTARY PUSH-BUTTON, HIGH CURRENT</p> <p>Protection: IP67 Rating current: 4 A Voltage: 30 VDC</p>	

POTENTIOMETER	F	<p>POTENTIOMER</p> <p>Ceramic potentiometer for industrial and professional use Protection: IP67 Mechanical travel: 300° Ohmic value: 1 kΩ, linear Operating temp: -40°C; +125°C The label can be customized</p>	
ROLLER SWITCH	G	<p>ROLLER (proportional voltage)</p> <p>Hall effect slide sensor Output signal: voltage (0-5V) Protection: IP67 with silicon boot Mechanical travel: $\pm 25^\circ$, with spring return to centre Operating temp: -40°C; +85°C</p>	
ROLLER SWITCH	H	<p>ROLLER (proportional PWM)</p> <p>Hall effect slide sensor Output signal: PWM (max 2 A) Protection: IP67 with silicon boot Mechanical travel: $\pm 25^\circ$, with spring return to centre Operating temp: -40°C; +85°C</p>	
MINI-JOYSTICK	I	<p>MINI-JOYSTICK 4-WAY MOMENTARY SWITCHES</p> <p>Protection: IP68 Rating current: 1 A Voltage: 28 VDC Mechanical travel: $\pm 18^\circ$, with spring return to centre Operating temp: -40°C; +85°C</p>	
TOGGLE SWITCH	L	<p>TOGGLE SWITCH LEVER</p> <p>Toggle bistable switch ON-OFF with rubber boot Protection: IP68 Rating current: 15 A Voltage: 28 VDC Operating temp: -40°C; +85°C</p>	

DEAD MAN FUNCTION

A - 2 push buttons (type A) are mounted in the rear side, both on left and right side



Code: D=1

B - 1 push button (type A) is mounted in the rear side centrally



Code: D=2

C - 1 push button (type B) is mounted in the rear side centrally



Code: D=3

D - Trigger actuator



Code: D=4

E - Capacitive sensor implemented into the handle
Code: D=5



CONNECTION TO STICK

Joystick connection (2800 and 2900)

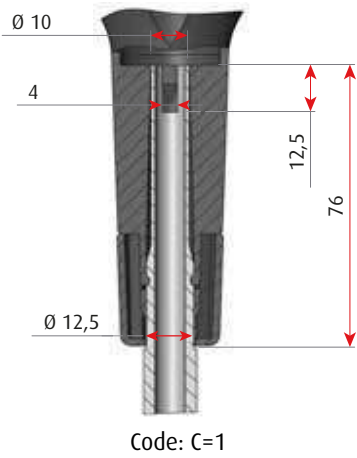

Connection with hole $\varnothing 12$ and pin

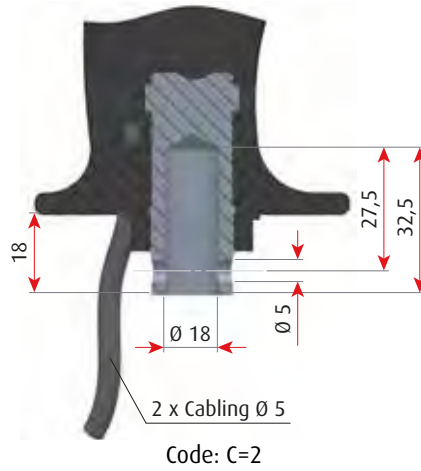

Connection with hole M10

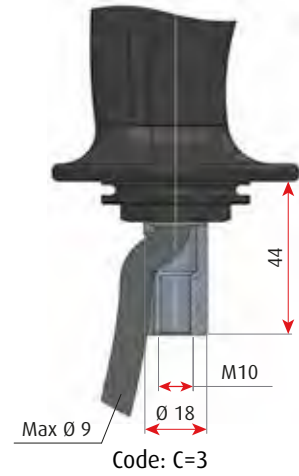

DEVICES COMBINATION

SWITCHES AND OTHER COMPONENTS		HANDLE					
		1705	1710	1715	1720	1725	1730
Push button	A			X	X	X	X
	B			X	X	X	X
	C					X	X
	D			X	X	X	X
	E		X	X	X	X	X
Potentiometer F						X	X
Roller G						X	X
Roller H							X
Mini-joystick I				X		X	X
Toggle switch L				X	X	X	X
Dead Man	A					X	X
	B					X	X
	C					X	X
	D					X	X
	E					X	X

Combination and position of the different devices on the same handle must be evaluated case per case.

CODING SYSTEM

HANDLE TYPE					DEAD MAN	HIGH CURRENT PUSH BUTTON	LOW CURRENT PUSH BUTTON		CONNECTION TO STICK	PROTECTION DEGREE		SPECIAL CUSTOM PROJECTS	
1	7	X	X	-	D	H	L	.	C	P	.	X	X

1	7	X	X
---	---	---	---

define the type of handle:

- 1705 = standard knob
- 1710 = anatomic knob
- 1715 = rear
- 1720 = rear black
- 1721 = rear grey
- 1725 = ergonomic handle
- 1730 = ergonomic XL handle

D defines the dead man solution:

- D = 0 no dead man function
- D = 1 round head push buttons mounted on the sides
- D = 2 round head push button mounted on the rear
- D = 3 flat head push button mounted on the rear
- D = 4 lever dead man
- D = 5 capacitative dead man

H number of high current push buttons:

- H = 0 no high current push button

L number of low current push buttons:

- L = 0 no low current push button

C defines the connection to the stick (lever):

- C = 0 stand alone version, no additional connection element, only the handle
- C = 1 connection to joystick (2800 and 2900)
- C = 2 connection with hole Ø12 and side pin
- C = 3 connection with hole M10

P defines the protection IP:

- P = 0 for internal/cabin use
- P = 1 IP65
- P = 2 IP67

X X numbering system from 0 to 99 is used to define special projects, cable length, type of connector, special push buttons and their position, dead man function, etc...



Notes



A series of horizontal dotted lines for writing notes, spanning the width of the page.



FLEXBALL
ITALIANA
WR CONTROLS GROUP



FLEXBALL
ITALIANA

WR CONTROLS GROUP



Flexball Italiana S.r.l.
Via San Luigi 13/A
10043 - Orbassano (To) Italy

Tel 0039.011.90.38.900
Fax 0039.011.90.38.747
info@flexballitaliana.com
www.flexballitaliana.com

