

**Marine
products**

FLEXBALL ITALIANA

WR CONTROLS GROUP

▼ Production sites



▼ **WR Controls Flexball**
Turin, Italy



▼ **WR Controls Europe**
Timmele, Sweden



▼ **WR Controls Asia**
Shanghai, China



▼ **WR Controls Europe**
Tallinn, Estonia



Global Manufacturing Facilities

From 2003 member of **WRControls Group**, with production facilities in Europe and Asia, **Flexball Italiana** offers since 50 years its experience both in the professional and pleasure boat sector, constantly focusing on design, production, innovation and quality improvement of mechanical and electronic controls.





Index

1 CABLES	p 5
Flexball Cables	p 6
Push-pull cables for engine and gearbox	p 12
2 MECHANICAL CONTROLS	p 17
3000 Mechanical control	p 18
3000 Mechanical control with trolling	p 24
3000 With electronic engine interface.....	p 27
3000 With electronic gearbox interface.....	p 29
3200 Mechanical control.....	p 31
350 Multilever control	p 33
590 Mechanical control.....	p 36
595 Mechanical controls	p 40
E95 Mechanical control lever	p 42
900 Marine application	p 44
3 ELECTRONIC CONTROLS	p 47
4000 Electronic control	p 48
4000 Electric.....	p 50
4100 Electric.....	p 52
4200 Side mounting electronic control	p 54
4200 Electric	p 56
4500 Electronic control	p 58
4500 Electric	p 67
4500 TLC	p 69
4500 Controllable pitch propeller.....	p 71
5000 Electronic control head	p 73
4500 Wireless remote control	p 75
4500 WPP Wireless portable panel.....	p 77

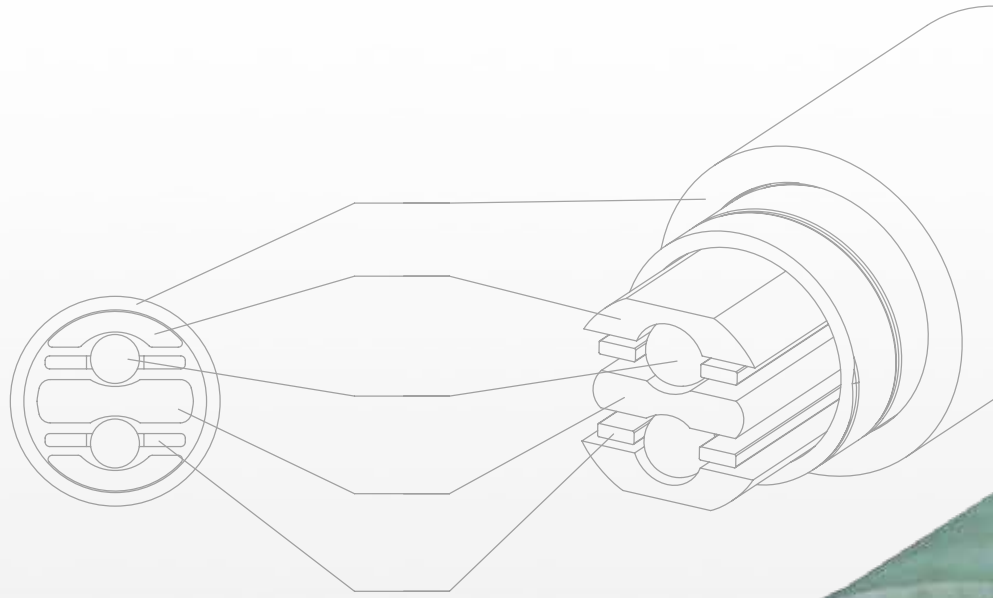

A large, bold, red number '1' is positioned on the right side of a green, curved surface. The surface appears to be part of a cable or a similar industrial component. The background is a light gray gradient with a subtle texture of horizontal lines.

Cables

FLEXBALL CABLES

For marine application

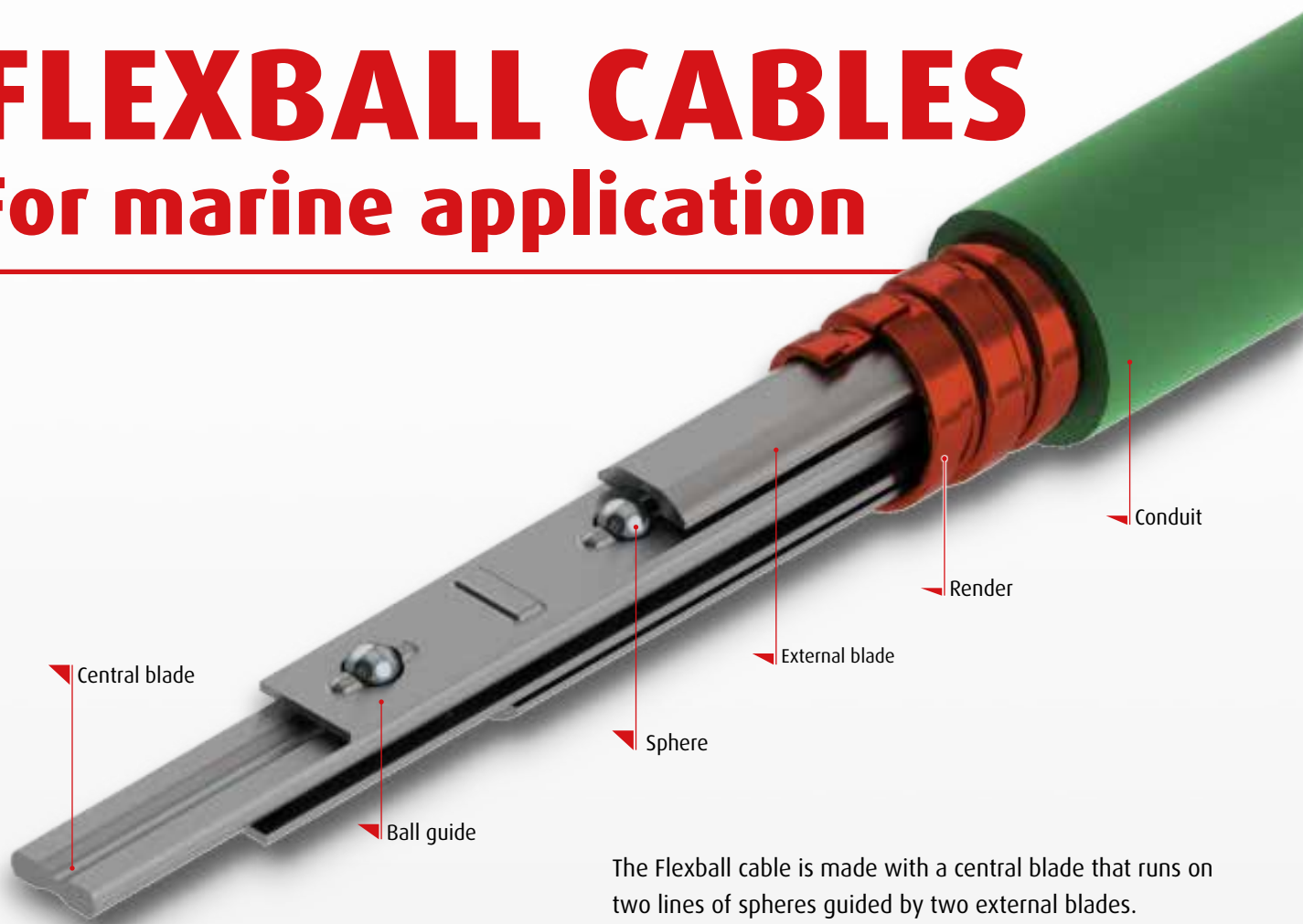

The **Flexball cable**, recognizable from the green colour of the plastic cover, is an extremely flexible and sliding cable. It has a very robust and reliable construction, with very high performances. If mounted properly, a Flexball cable can work “for ever”.

Flexball cables are mainly used on boat in which long distances have to be covered, high loads have to be transmitted and the reliability is a “key word”.

The Flexball cable is made with a central blade that runs on two lines of spheres guided by two external blades.

Materials used change according to the application: for industrial application terminals are in steel zinc while for marine applications terminals are either made with brass or stainless steel. Internal blades are stainless steel AISI304L for any kind of applications.

Flexball cables are used in any kind of special applications. If this is the case, please feel free to contact our technical department.

For a proper mounting, look at our “Mounting instructions”.

The **Flexball cable** is delivered in a proper box and bent with an “8” shape to respect its minimum bending radius. Once received, it should be opened and stored in a straight line. If not possible, we suggest to leave it in the box like you have received it. Flexball cable must not be stored in a circular way, otherwise it can be seriously damaged.

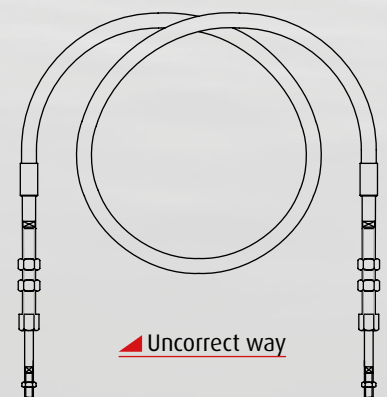
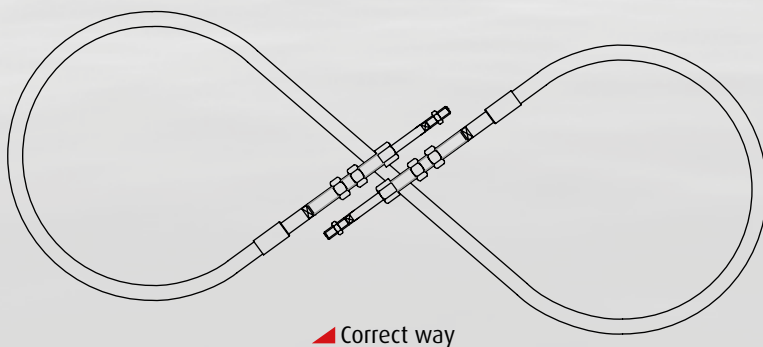

The **Flexball cables** are available with several types of end fittings to fit the different application requirements.

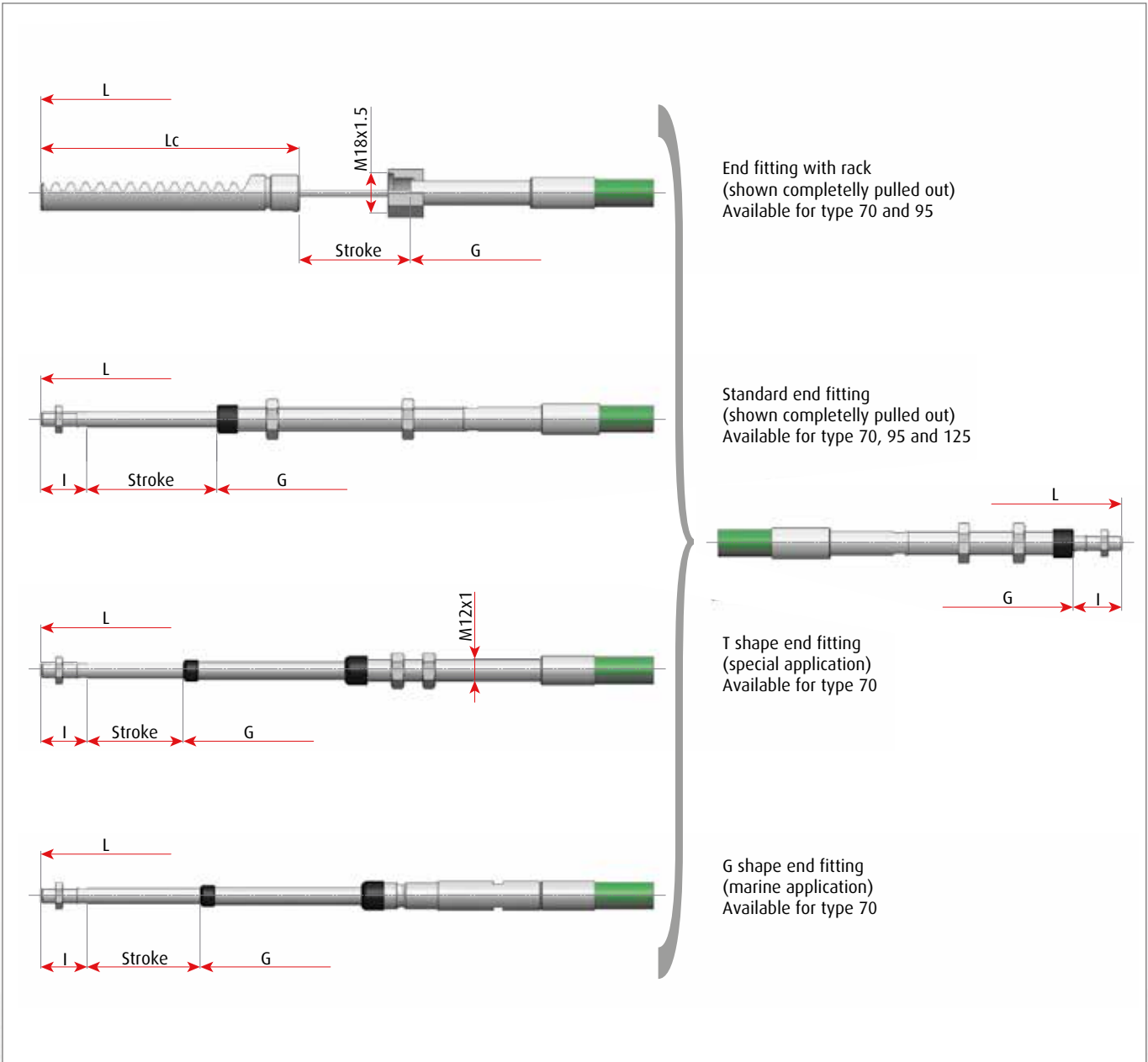

PRODUCT RANGE AND APPLICATION

The Flexball cable is available in different sizes, from type 70 up to type 125.

Type 70 is commonly used for throttle and gearbox type 95 for gearbox in case of very long route and heavy duty application like winch and hydrostatic pump and type 125 is commonly used for steering system.

STANDARD FLEXBALL END FITTING DIMENSIONS

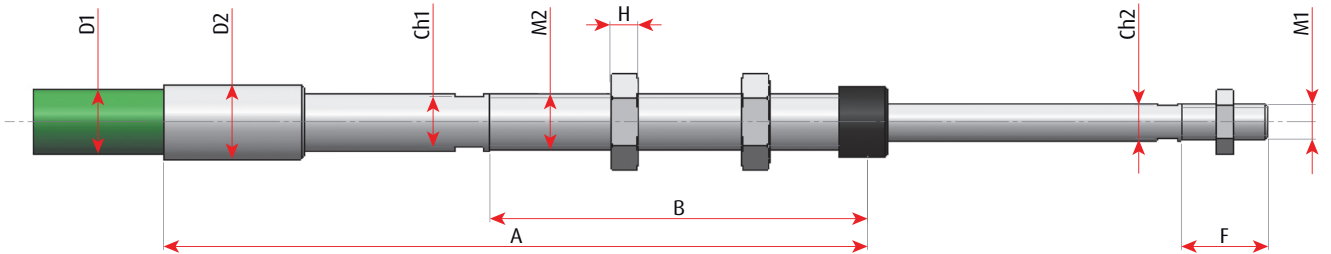

Cable type	Stroke	A	B	F	H	I	Ch1	Ch2	D1	D2	M1	M2	LC	Rack module (mm)	Push load (N)	Pull load (N)	Bending radius (mm)	Weight per meter (gr)	E_c
70	50	142	55	30	8	37	11	6	11.7	14	M7x1(M6x1)	M12x1	126	1.5	1550	2800	120	320	0.18
	70	157	70																
	100	187	100																
	150	237	150																
	200	292	170																
95	50	163	70	30	8	37	14	9	14.7	18	M10x1.5	M16x1.5	126	1.5	2700	5000	140	518	0.15
	70	183	90																
	100	213	120																
	150	263	170																
	200	313	220																
125	50	195	70	35	9	45	17	11	18	21	M12x1.5	M18x1.5	-	1.5	5300	10000	200	827	0.05
	70	215	90																
	100	245	120																
	150	295	170																
	200	345	210						20.8	24			295						
												345	1200						

Notes:

Cable's elongation (mm): cable's length (m) x applied Load (N) x E_c x 0.01

ACCESSORIES

CLEVIS

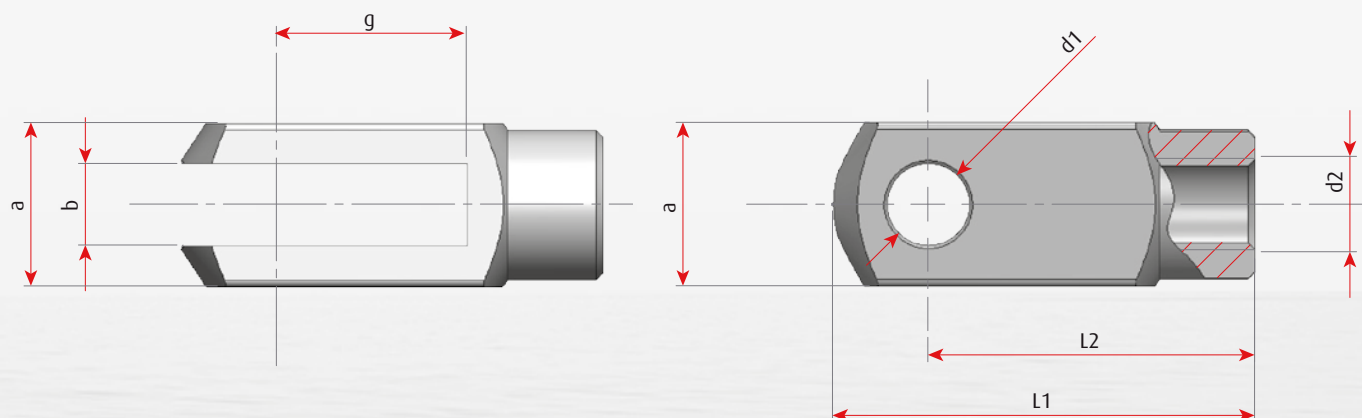
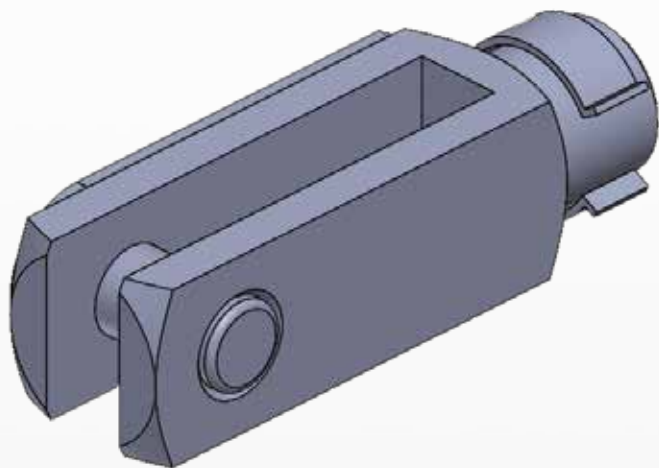

Type	B	d1	d2	g	a	L1	L2	Clevis code	Set Code (clevis + pin)
6x24	6	6	M6	32	16	58	48	D-0099.01.04.04	0-0099.01.00.11
6x24	6	6	M7	32	16	58	48	D-0099.01.04.05	0-0099.01.00.12
10x40	10	10	M10x1,5	40	20	72	60	D-0099.01.08.03	0-0099.01.00.27
12x48	12	12	M12x1,5	48	24	72	86	D-0099.01.09.02	0-0099.01.00.30

Note:

all the clevis listed here above are in brass.

BALL JOINT

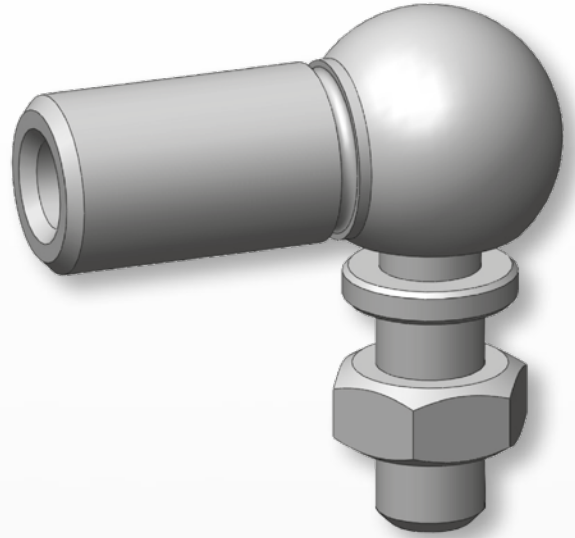
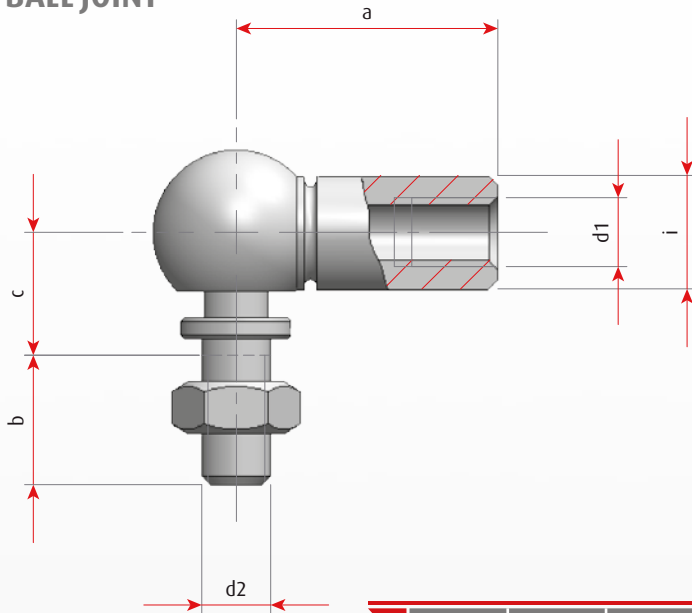

Type	a	i	d1	d2	c	b	Code
AS10	25	12	M6	M6	11	8	D-0099.04.03.00
AS13	30	14	M6	M8	13	12	D-0099.04.07.02
	30	14	M7	M7	13	12	D-0099.04.06.00
	30	14	M7	M8	13	12	D-0099.04.07.01
AS16	35	16	M10	M10	16	14	D-0099.04.09.00

Note:

all the ball joints listed here above are in steel zinc coated.

CLAMP

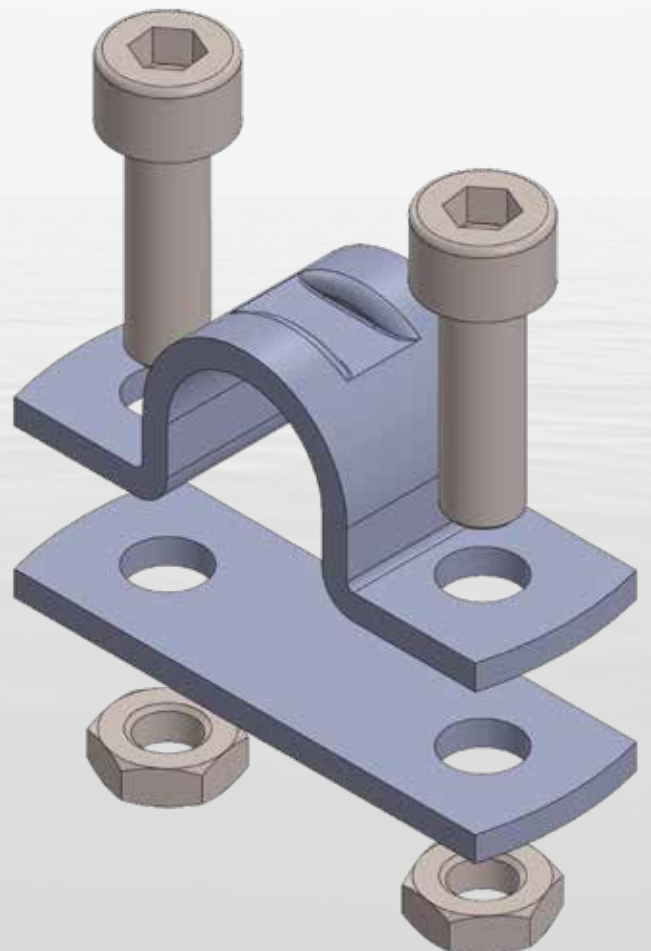
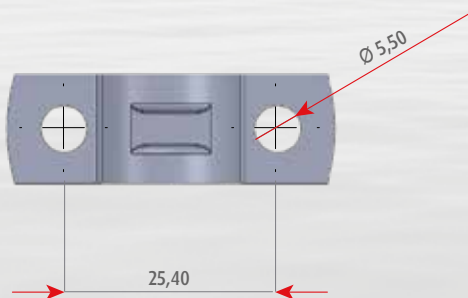

Type of cable	R	Set Code (clamp + bracket + 2 screws + 2 nuts)
70 (G shape)	12,5	0-0099.11.06.02

BULKHEAD SWIVEL

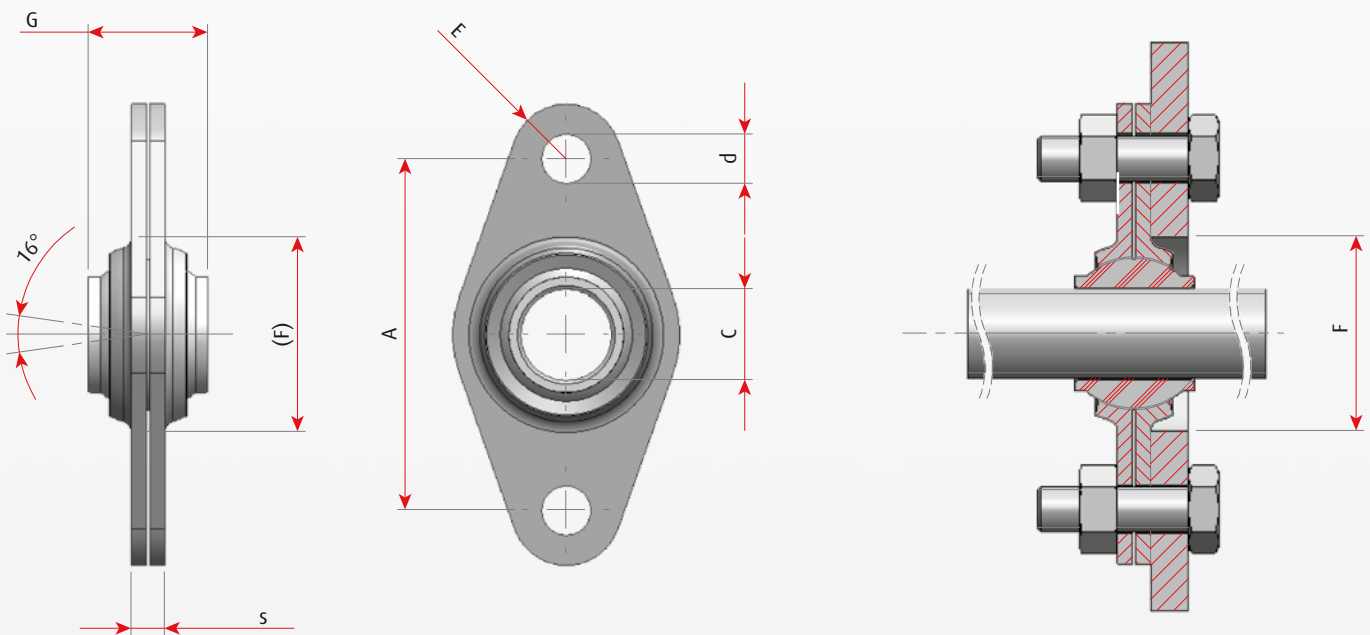
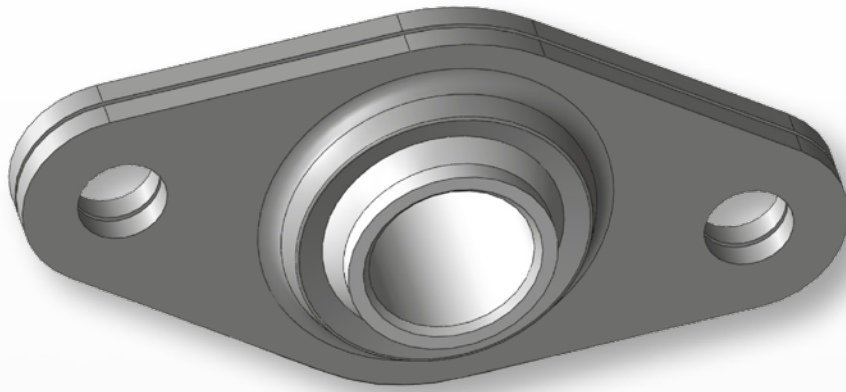

Note:





"F" is the dimension of the hole that has to be drilled on the bracket where the bulkhead swivel will be fixed. The above picture shows the correct mounting of the bulkhead against the bracket.

Type	A	b	C	F	G	s	Ch	Material	Code
70	40	6.2	12.2	25	16	4	17	Brass	0-0099.03.00.05
95	52	8.2	16.2	34	22	5	25	Brass	0-0099.03.00.08
125	56	8.2	18.2	36	25	5	27	Brass	0-0099.03.00.10

PUSH-PULL CABLES

For marine engine and gearbox

Flexball offers a full range of push-pull cables both for the pleasure boats and for the professional boats sector. All cables are supplied with either brass or stainless steel terminals.

Type	Code	Stroke (mm)	Thread 1 st end	Thread 2 nd end	Conduit diameter	Application
E2	E2-fff	80	10/32 UNF	10/32 UNF	7	Volvo Penta®: inboard, sterndrive
						
E3	E3-fff	80	10/32 UNF	10/32 UNF	8	Volvo Penta®: inboard, sterndrive
						
E4	E4-fff	80	1/4X28 UNF	1/4X28 UNF	9,5	Volvo Penta®: inboard, sterndrive
						
E6	E6-mm.mmM	80	M6	M6	9,5	Special applications
						

HOW TO ORDER

With the exception of E6 cables, which are used for special applications, the length of all the other cable is in feet.

To convert feet to meters multiply by 0.305 and round to the nearest quarter of a meter.

To convert meters to feet, divide by 0.305 and round up to next foot.

If for example we need to use a 4.5 meter cable, the length in feet is:

$$4.5: 0.305 = 14.75$$

so, rounding to the next foot, the length to order is 15 feet.

For installations with outboard motors it is advisable to add 1 meter (3 feet) to the measured length; this will allow the proper movement of the engine.

The ordering code structure of the cable is as follows:

E	x	-	f	f	F
---	---	---	---	---	---

The parameters which must be filled into the table to specify the cable are x and ff:

- x = 1,2,3,4, 5 identifies the type of cable
- ff is the cable length in feet

For example, if we order 13-feet cable type E5, the code is: E5-13F

ACCESSORIES

CLEVIS

To determine the right size of the fork, look at the dimension "M1" on the drawings and tables of Flexball, pull and push-pull cables.

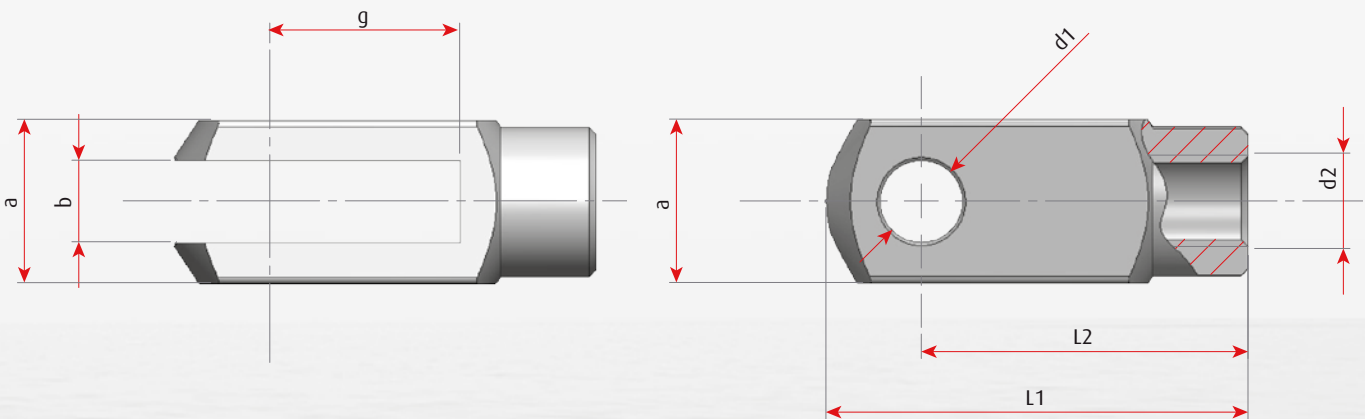
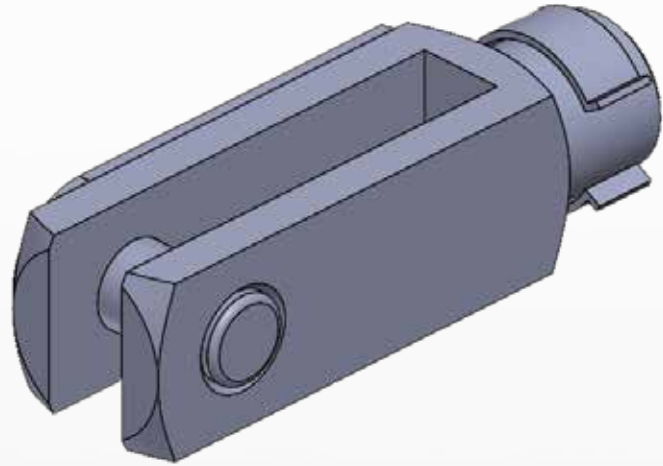

Type	B	d1	d2	g	a	L1	L2	Clevis code	Set Code (clevis + pin)
5x10	5	5	M5	10	10	26	20	D-0099.01.01.01	0-0099.01.00.01
5x20	5	5	M5	20	10	36	30	D-0099.01.02.01	0-0099.01.00.03
6x24	6	6	1/4x28	32	16	58	48	D-0099.01.04.10	0-0099.01.00.00

Note:

Accessories with thread M5 can be used on cables with rod thread 10/32 UNF



BALL JOINT

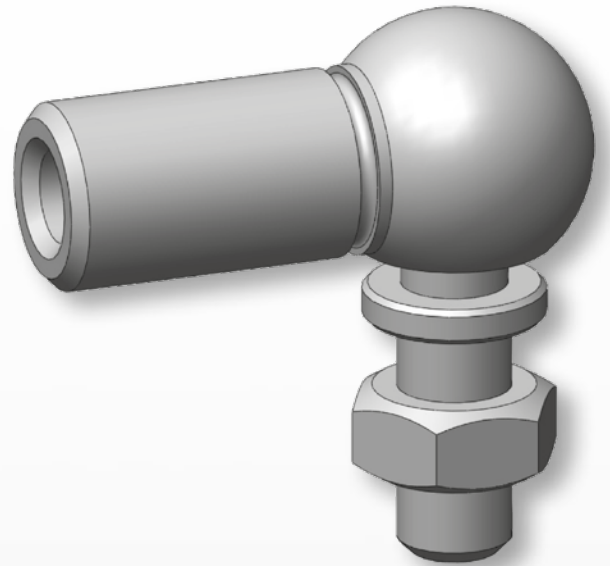
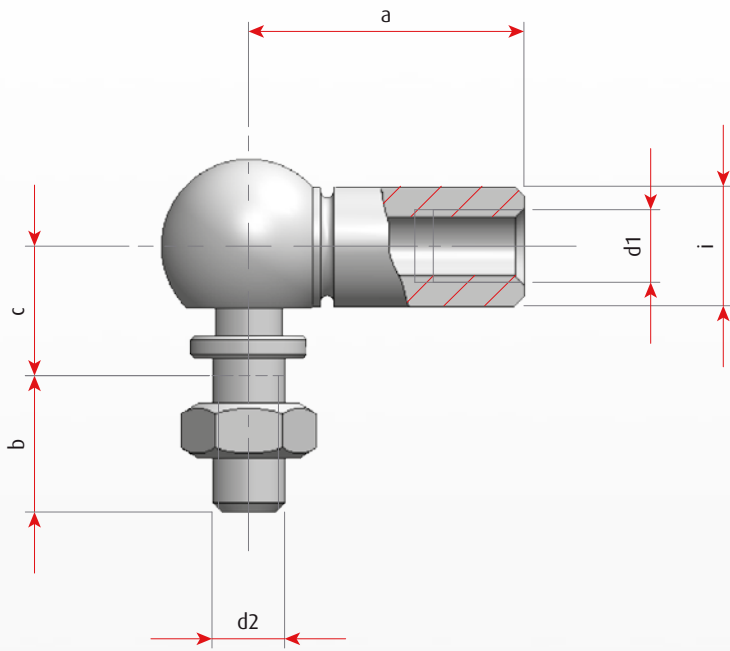

Type	a	i	d1	d2	c	b	Code
AS8	22	10	M5	M5	9	7	D-0099.04.01.00

CLAMP

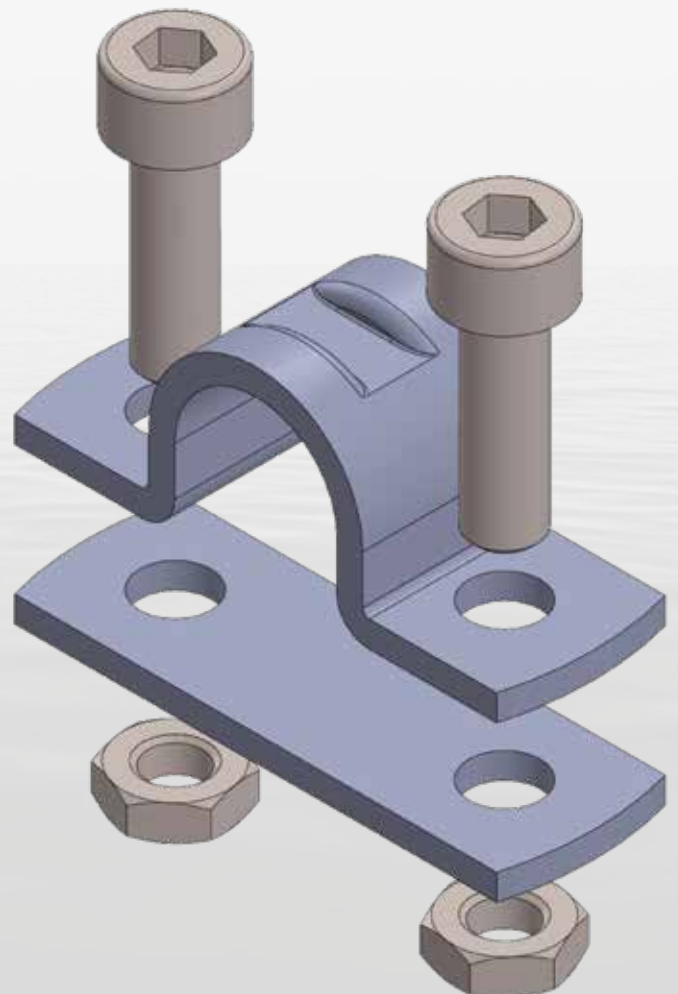
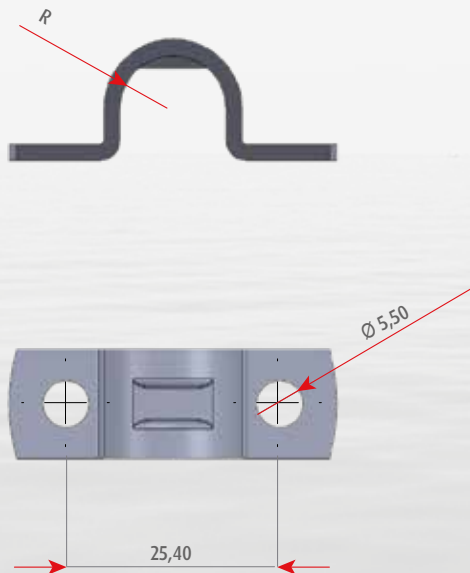

Type of cable	R	Set Code (clamp + bracket + 2 screws + 2 nuts)
E2/E3	9,5	0-0099.11.06.01
E4	12,5	0-0099.11.06.02

DUAL STATION SELECTOR

Combines the action of the single lever control from either of two command stations and provides a single output to the gearbox lever.

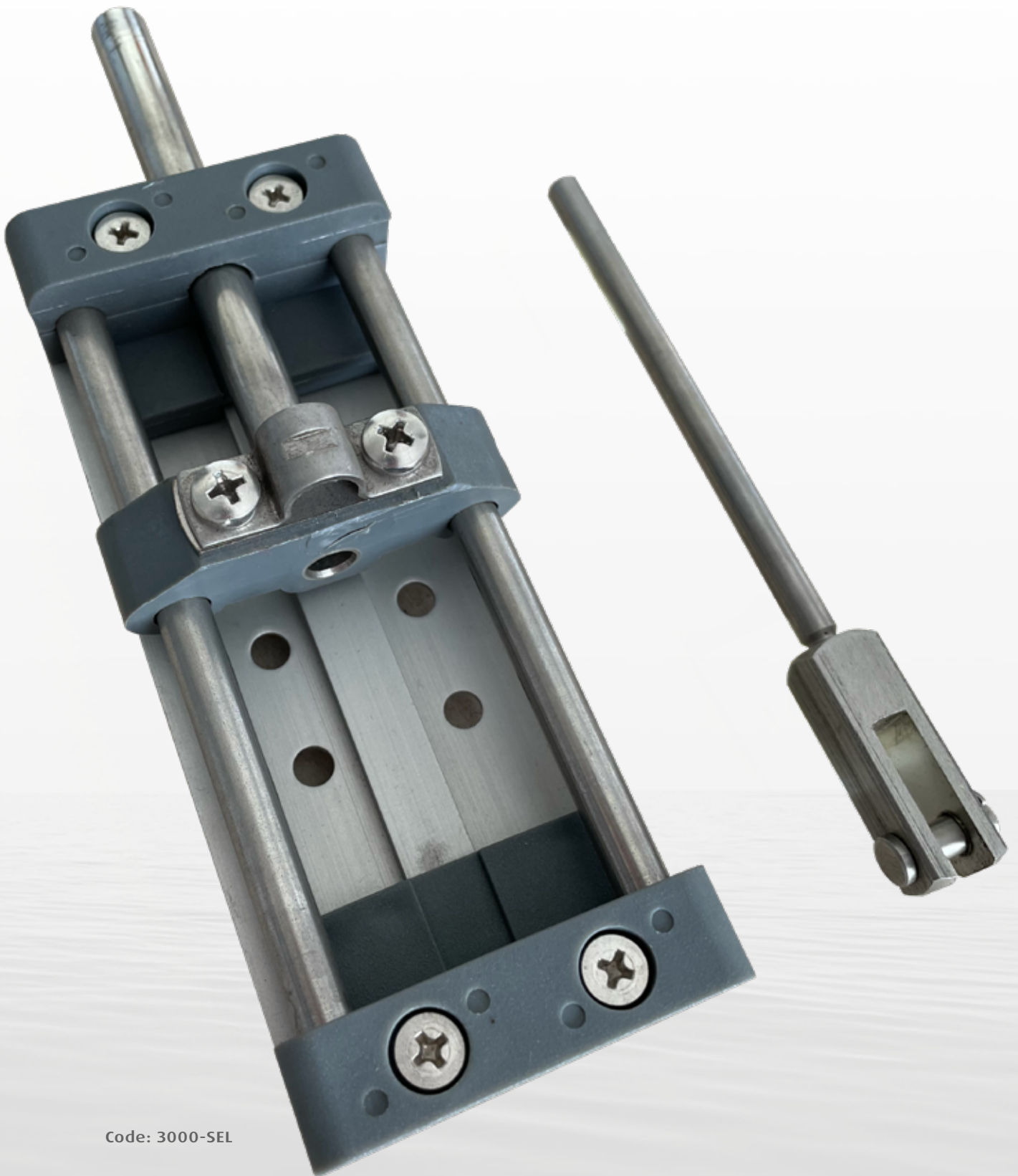

Code: 3000-SEL



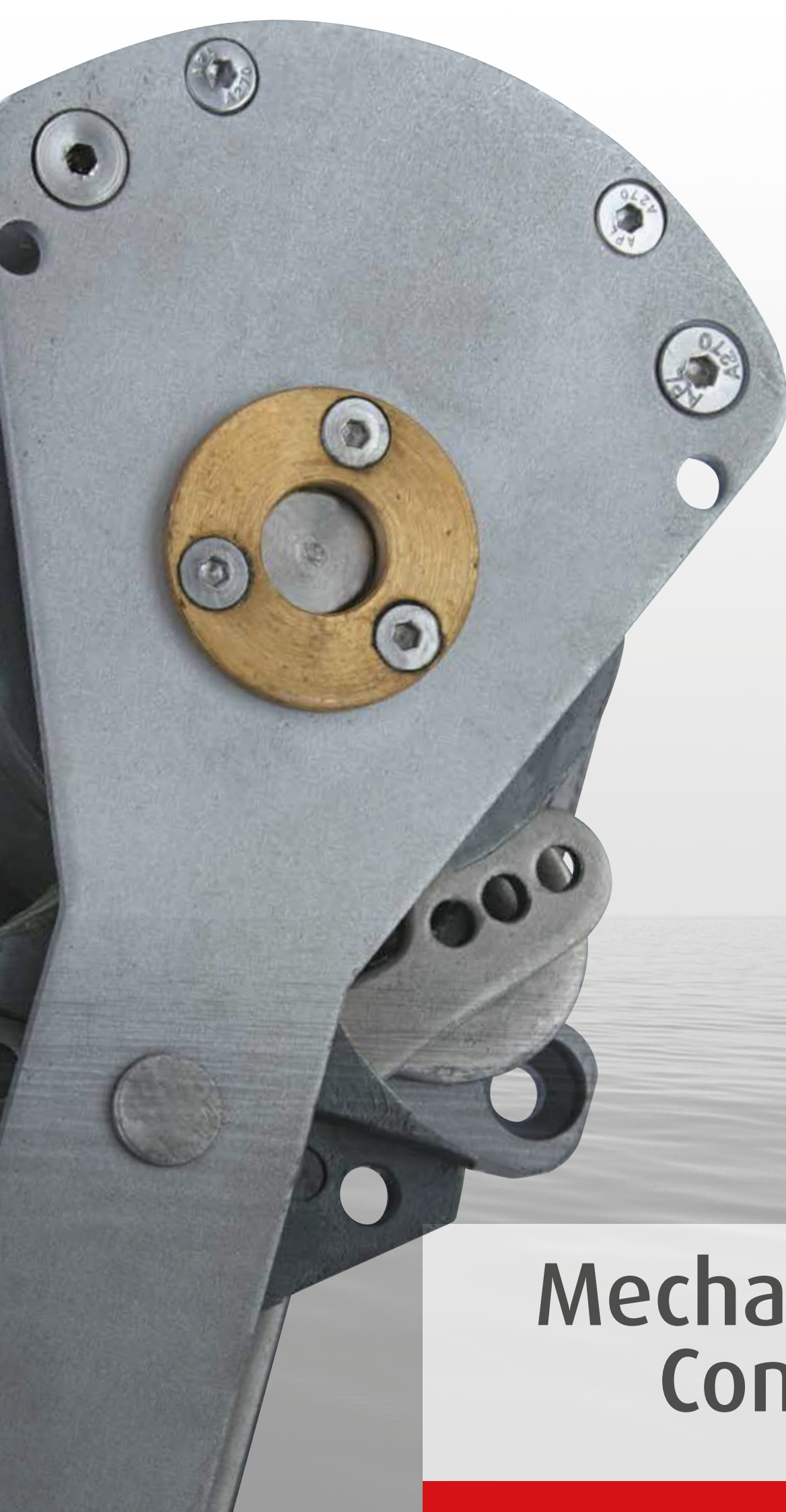

2

Mechanical Controls

3000

Mechanical control

These mechanical lever controls are available in several versions and fulfil all the possible application requirements including pleasure boats, passenger boats and professional vessels. There are also available versions for the direct control of electronic and CANBus motors.



OPERATION

Single lever with dual action for the sequence command of gearbox and throttle. The button, when inserted into the body of the lever, disengages the gearbox and enables the acceleration of the engine in neutral (warm-up).

STROKES

From 60 to 80 mm both for gearbox and throttle (you can get a fine regulation by tuning the slot inside the lever).

MOVEMENTS

Extremely smooth and precise, due to the bearings and sintered bronze bushings; there are no plastic parts.

AESTHETICS

- Body box is available chrome plated, painted black or stainless steel (only for the version with 1 motor).
- Lever can be either chrome or stainless steel. Handle and button for warm-up are available red or black.

COMMAND CABLES

Command levers Series 3000 can be used with conventional push-pull cables E3 (thread 10/32), E4 (thread 1/4 x 28) E6 (thread M6) and the very performing Flexball cables Series 70 (M6 thread).

VERSIONS

- 3000.1 model for one motor or 3000.2 model for two motors for boats with a single command station
- in case of boats with more command stations:
3033.1 to be connected with one or more repeater levers 3030.1, in case of boats with 1 motor 3033.2 to be connected with one or more repeater levers 3030.2, in case of boats with 2 motors.

All models can be single or coupled. The results are the following combinations:



SYSTEMS WITH TWO COMMAND STATIONS

There are two different philosophies and methods for connecting together levers 3000:

- Master/repeater: a master command station is connected to a repeater command station. In this case when moving one command station the other one follows automatically the movements of the first station.
- Sleigh: command stations are identical and are not directly linked together. The selection of the command is done through a slide which is mounted near the engine. The station at the moment not in use must be kept in neutral position.

The solution master/repeater is absolutely the best in term of performance.

PRODUCT RANGE

DESCRIPTION	CODE
• Command lever inox for 1 motor; red handle	3000.1-XR
• Master inox for 1 motor; red handle	3033.1-XR
• Repeater inox for 1 motor; red handle	3030.1-XR
• Command lever chrome plated for 1 motor; red handle	3000.1-CR
• Command lever black for 1 motor; red handle	3000.1-SR
• Command lever chrome plated for 2 motor; red handles	3000.2-CR
• Command lever black for 2 motors; red handles	3000.2-SR
• Master chrome plated for 1 motor; red handle	3033.1-CR
• Master black for 1 motor; red handle	3033.1-SR
• Master chrome plated for 2 motors; red handles	3033.2-CR
• Master black for 2 motors; red handles	3033.2-SR
• Repeater chrome plated for 1 motor; red handle	3030.1-CR
• Repeater black for 1 motor; red handle	3030.1-SR
• Repeater black for 2 motors; red handles	3030.2-CR
• Repeater black for 2 motors; red handles	3030.2-SR
• Sliding device for 2 command stations	3000-SEL
• Connecting kit (2 clamps + 2 forks) for cables E3 Series (thread 10/32)	3000-E3
• Connecting kit (2 clamps + 2 forks) for cables E4 Series (thread 1/4 x 28)	3000-E4
• Connecting kit (2 clamps + 2 forks) for cables Flexball 70 (thread M6 x 1)	3000-70



INSTALLATION SCHEME FOR 2 COMMAND STATIONS AND 1 MOTOR

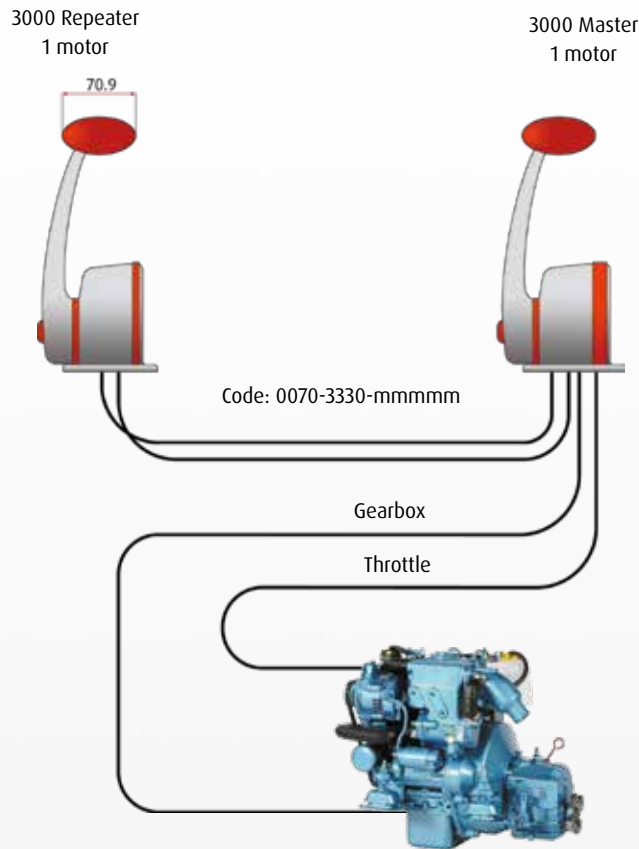

Note:

mmmmm is the cable length in mm

INSTALLATION SCHEME FOR 2 COMMAND STATIONS AND 2 MOTORS

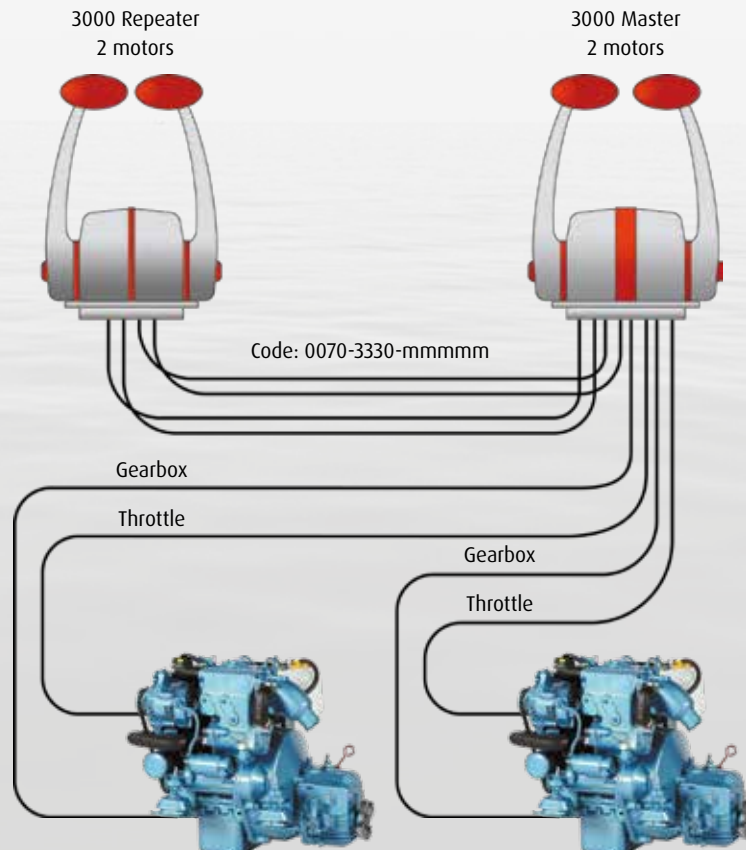

Note:

mmmmm is the cable length in mm

INSTALLATION SCHEME FOR 2 INDEPENDENT COMMAND STATIONS

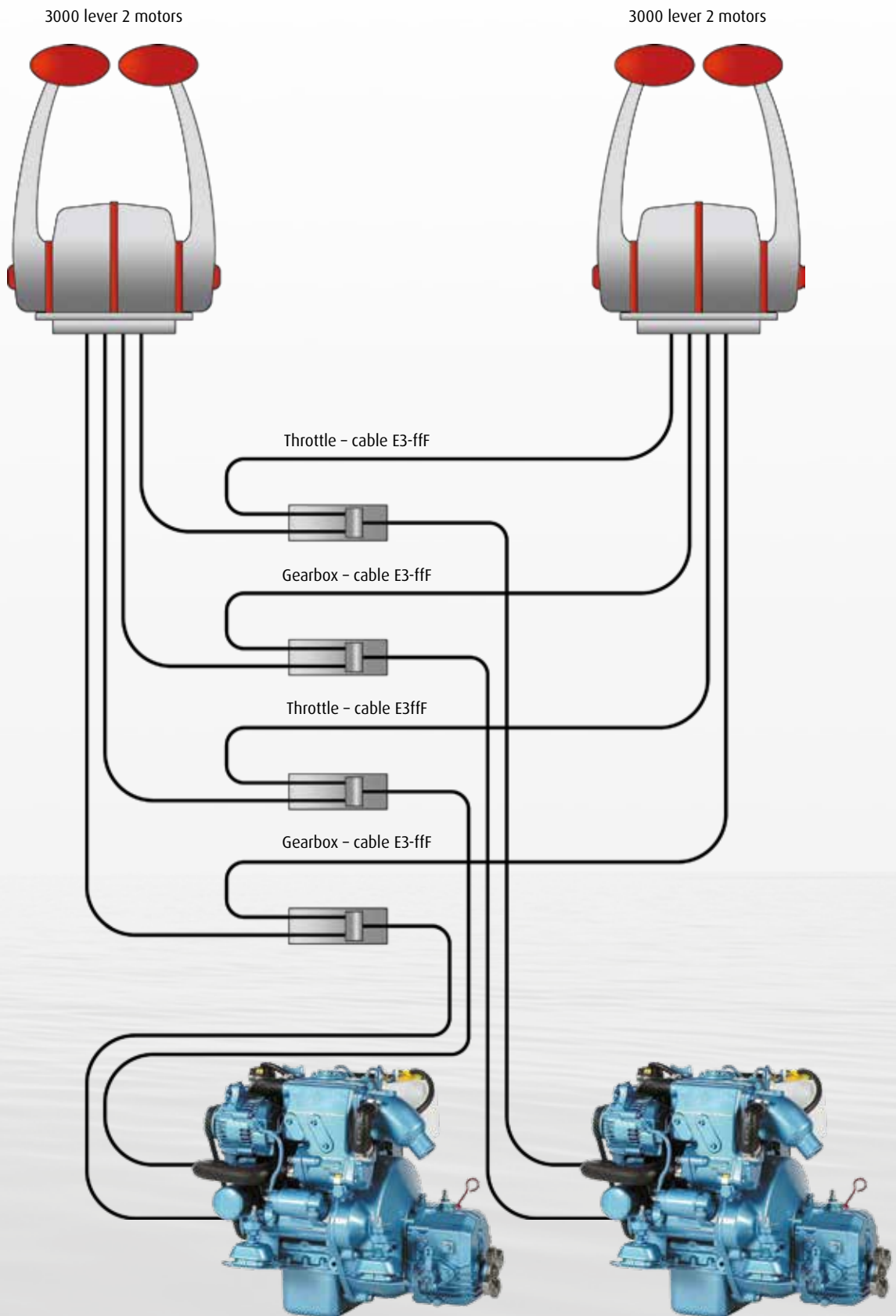

Note:

ff is the cable length in feet. Example: cable E3 L=10 feet → E3-10F

OVERALL DIMENSIONS

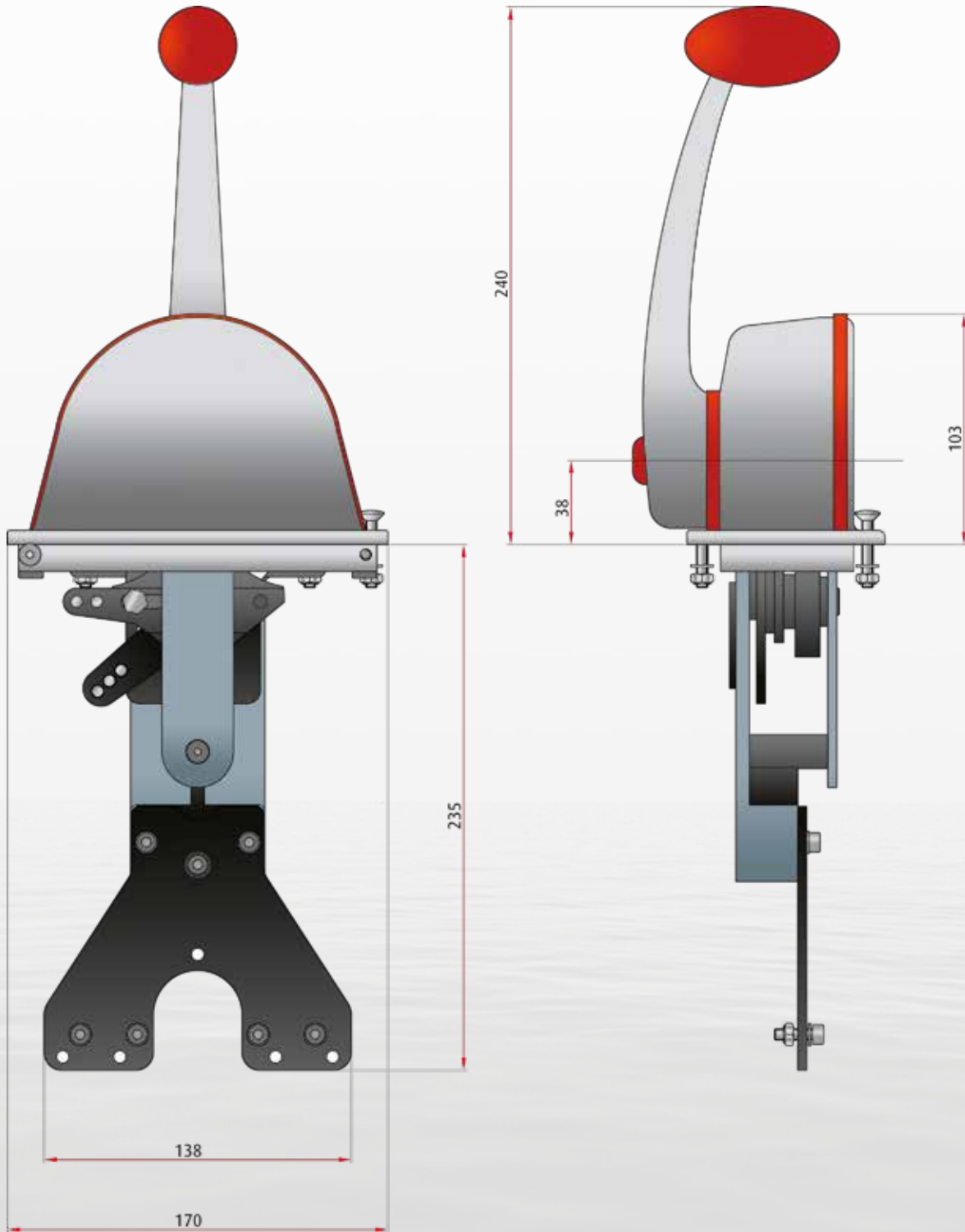

DIMENSIONS, FOOTPRINTS AND DRILLING MASKS

3000 Lever for 1 motor
3000 Repeater for 1 motor

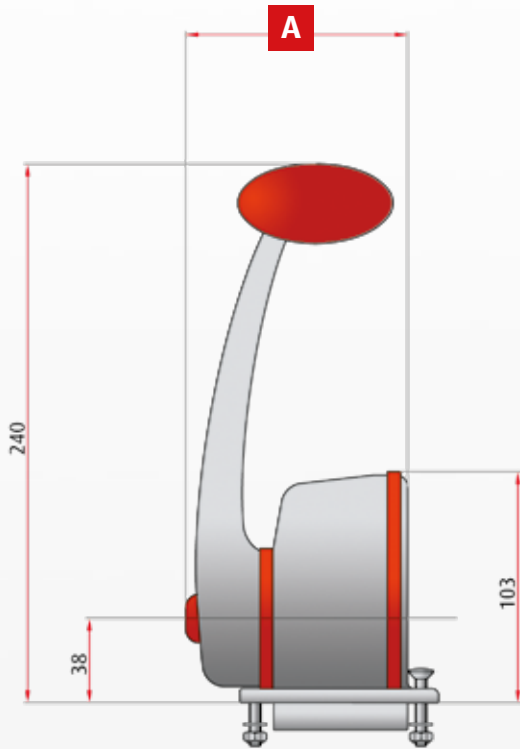

3000 Lever for 2 motors
3000 Repeater for 2 motors

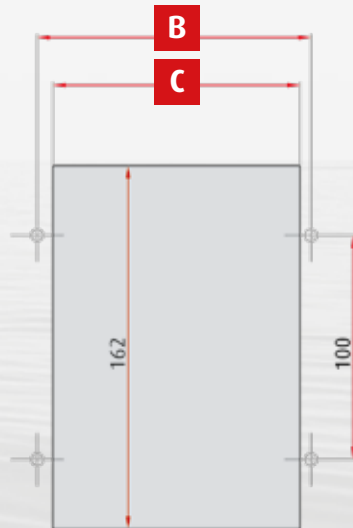
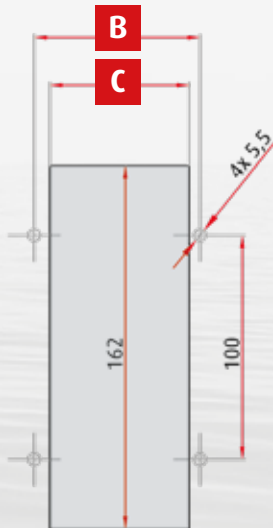
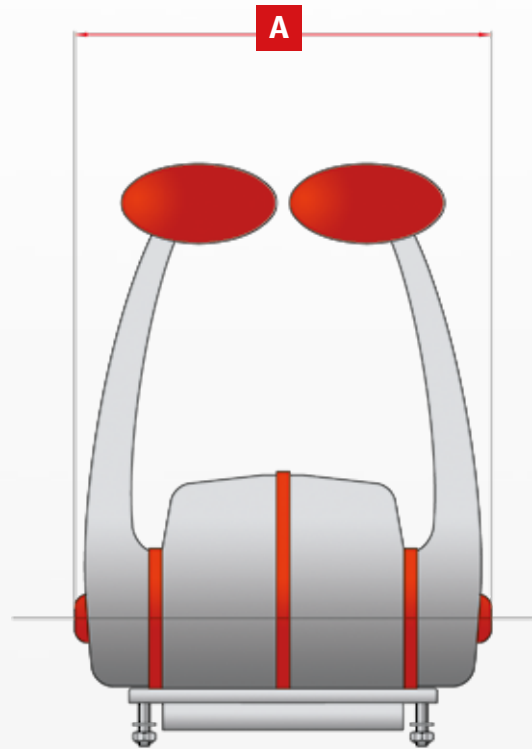

REFERENCE	LEVER FOR 1 MOTOR REPEATER FOR 1 MOTOR	LEVER FOR 2 MOTORS REPEATER FOR 2 MOTORS	LEVER MASTER 1 MOTOR	LEVER MASTER 2 MOTORS
A	100	186	115	218
B	75	122	90	154
C	62	110	77	141



3000

Mechanical control with trolling

Command lever for the control of throttle, gearbox and trolling valve; the system can be configured for more command stations. It is very indicated for fishing on professional and pleasure boats as well



PRODUCT RANGE

DESCRIPTION	CODE
• Single lever chrome plated for 1 motor + trolling; red handle	30090.1-CR
• Single lever black for 1 motor + trolling; red handle	30090.1-SR
• Master chrome plated for 1 motor + trolling; red handle	3390.1-CR
• Master black for 1 motor + trolling; red handle	3390.1-SR
• Repeater chrome plated for 1 motor + trolling; red handle	3090.1-CR
• Repeater black for 1 motor + trolling; red handle	3090.1-SR

INSTALLATION SCHEME FOR 2 COMMAND STATIONS

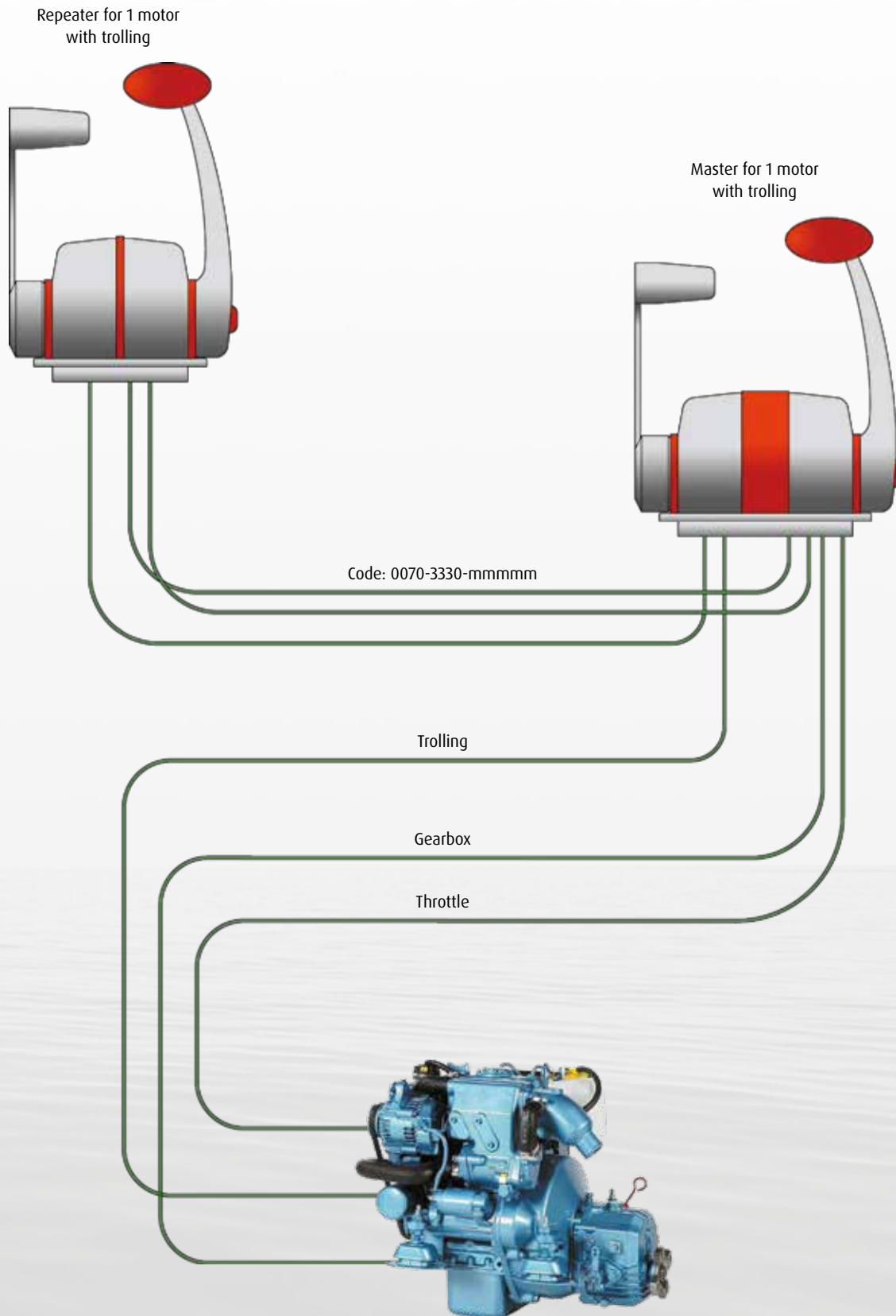

Note:
mmmmmm is the length in mm



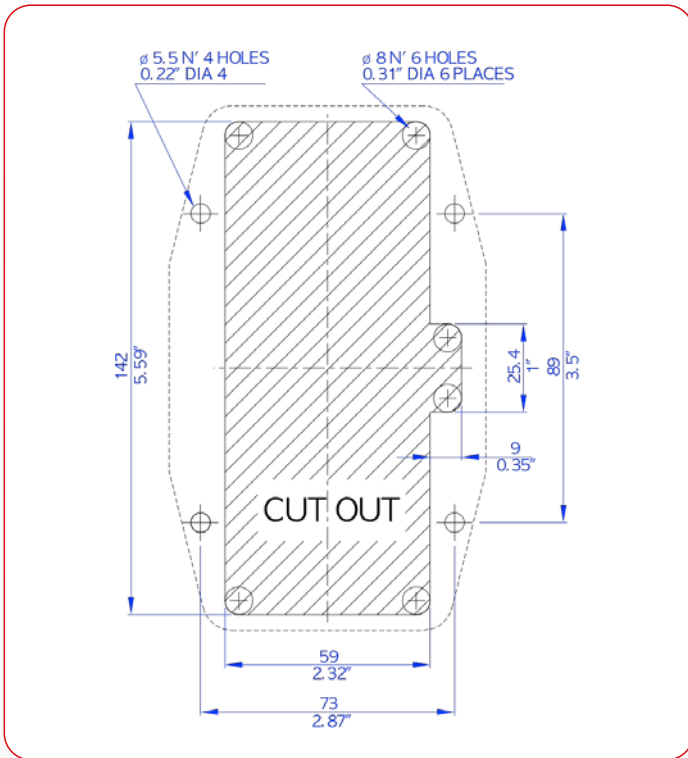

3200.1 Single control template

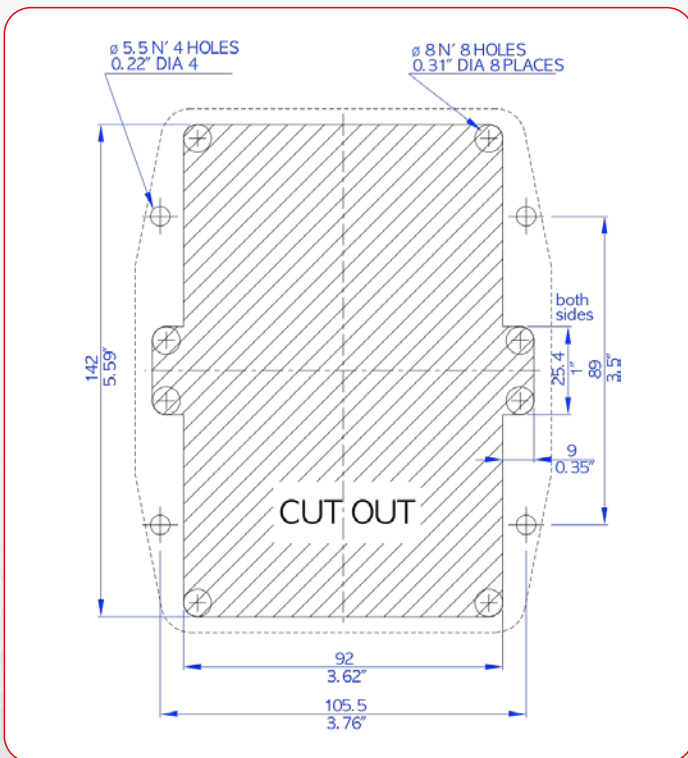

3200.2 Twin control template

To be noticed: drawings above are not to scale

3000

With electronic engine interface

This lever allows you to interface directly to the new electronic and CANBus common-rail engines, combined with mechanical gearboxes



COMPONENTS AND TECHNICAL SPECIFICATIONS

With this lever it is possible to set up large installations that would be impossible to achieve with traditional mechanical systems:

- thanks to the electronic transmission of the signal, the control of electronic motors is fast, secure and easy to install
- the command of the gearbox is either via a Flexball cable, thus ensuring the requirements of precise handling and reliability that are typical of the Flexball cable, or through a standard push-pull cable.

This solution has further advantages in case of installations with multiple control stations (see diagram on next page). With this control system it is very easy to make a perfect change of command from one station to another, also during navigation. Since the levers are mechanically bounded to each other, when moving a lever, the other follows.

In the transition from one station to the other, the pilot finds the lever on which he has just come, exactly in the same position of the lever that he has left and the engine's working conditions remain unchanged.

This lever is compatible with all electronic engines with voltage, current and CANbus interface.



INSTALLATION SCHEME

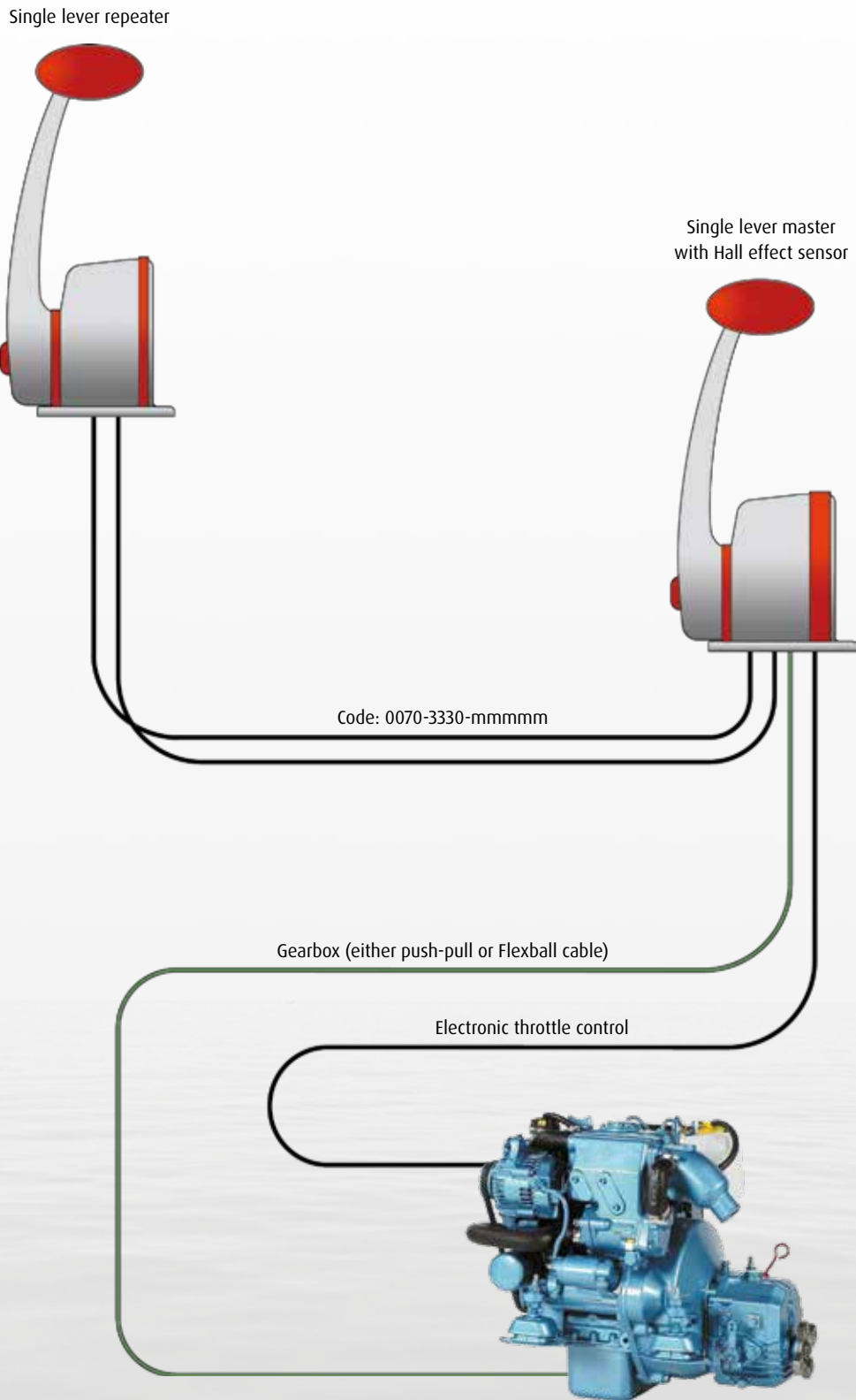

Note:
mmmmmm is the length in mm

3000

With electronic gearbox interface

▼ This lever allows you to interface directly to electronic gearbox (solenoid driven) combined with mechanical engine



COMPONENTS AND TECHNICAL SPECIFICATIONS

With this lever it is possible to set up large installations that would be impossible to achieve with traditional mechanical systems.

Inside the control station are implemented electronic switches for reverse and forward positions while the command of the throttle engine is either via a Flexball cable, thus ensuring the requirements of precise handling and reliability that are typical of the Flexball cable, or through a standard push-pull cable.

This solution has further advantages in case of installations with multiple control stations (see diagram on next page).

With this control system it is very easy to make a perfect change of command from one station to another, also during navigation. Since the levers are mechanically bounded to each other, when moving a lever, the other follows. In the transition from one station to the other, the pilot finds the lever on which he has just come, exactly in the same position of the lever that he has left and the engine's working conditions remain unchanged.



INSTALLATION SCHEME

Single lever repeater

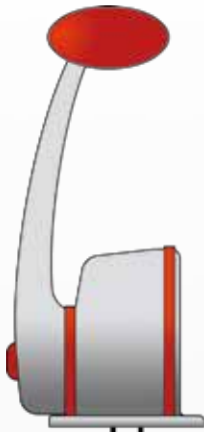

Single lever master with Hall effect sensor

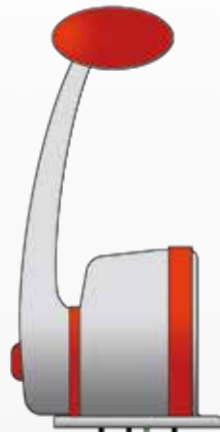

Code: 0070-3330-mmmmm

Throttle (either push-pull or Flexball cable)

Electrical cable to gearbox (fare linea cavo nera)

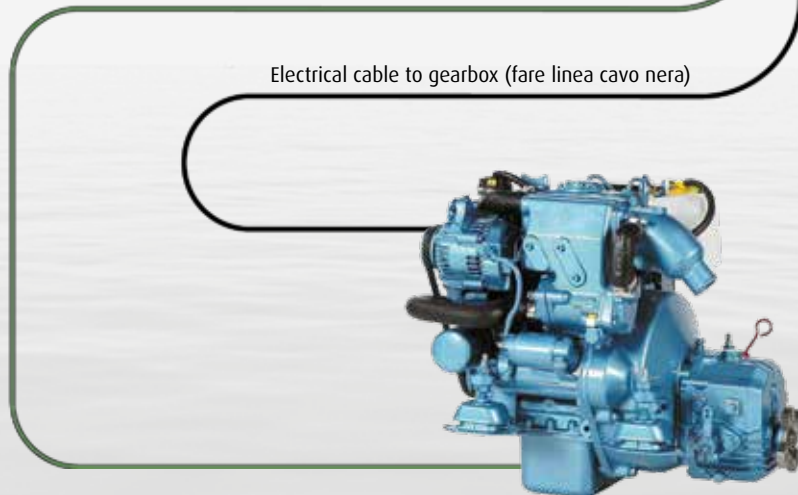

Note:

mmmmmm is the length in mm

3200

Mechanical control

▼ 3200.1 single



▼ 3200.2 twin



SPECIFICATION

- Double action (throttle/shift control)
- Warm-up function
- Starting in gear prevention through a neutral safety switch (option)
- Adjustable shift control stroke
- Suitable for inboard, outboard and stern drive configuration

DIMENSIONS, FOOTPRINTS AND DRILLING MASKS

Repeater single lever
+ troling for 1 motor

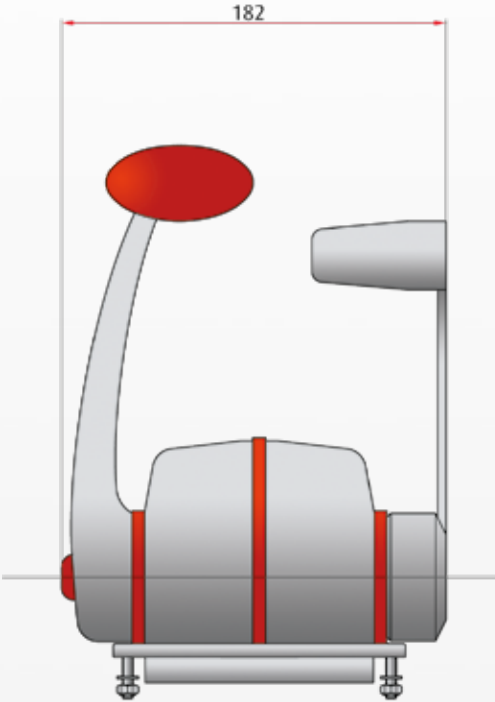

Master single lever
+ troling for 1 motor

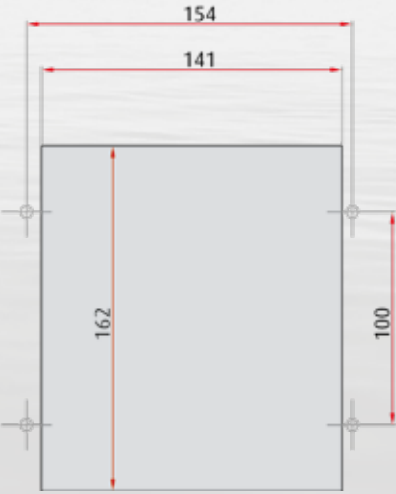
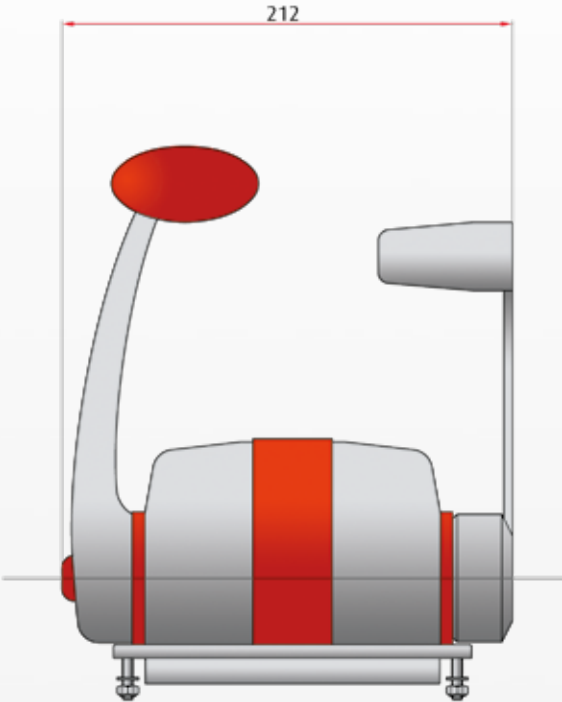

350 Multilever control

It is a very simple and modular control system that can be used either as throttle or gearbox command lever in different combinations. Maximum system configuration is 6 control levers.

TECHNICAL FEATURES

- available with different lever lengths
- suitable for application on off-shore boats
- internal mechanism in stainless steel
- moving on bushes
- external house in aluminium black painted
- fixing mask in stainless steel polished.



PRODUCT RANGE

DESCRIPTION	CODE
Lever for throttle command	
• Control unit with lever L=180 mm, push version	350.00
• Control unit with lever L=150 mm, push version	350.01
• Control unit with lever L=125 mm, push version	350.02
• Control unit with lever L=200 mm, push version	350.03
• Control unit with lever L=180 mm, pull version	351.00
• Control unit with lever L=150 mm, pull version	351.01
• Control unit with lever L=125 mm, pull version	351.02
• Control unit with lever L=200 mm, pull version	351.03
Lever for gearbox command	
• Control unit with lever L=180 mm, push version	355.00
• Control unit with lever L=150 mm, push version	355.01
• Control unit with lever L=125 mm, push version	355.02
• Control unit with lever L=200 mm, push version	355.03
• Control unit with lever L=180 mm, pull version	356.00
• Control unit with lever L=150 mm, pull version	356.01
• Control unit with lever L=125 mm, pull version	356.02
• Control unit with lever L=200 mm, pull version	356.03
Accessories	
• Fixing mask for single lever	1135.01
• Fixing mask for two levers	1135.02
• Fixing mask for three levers	1135.03
• Fixing mask for four levers	1135.04
• Fixing mask for five levers	1135.05
• Fixing mask for six levers	1135.06



INSTALLATION SCHEME FOR ONE COMMAND STATION

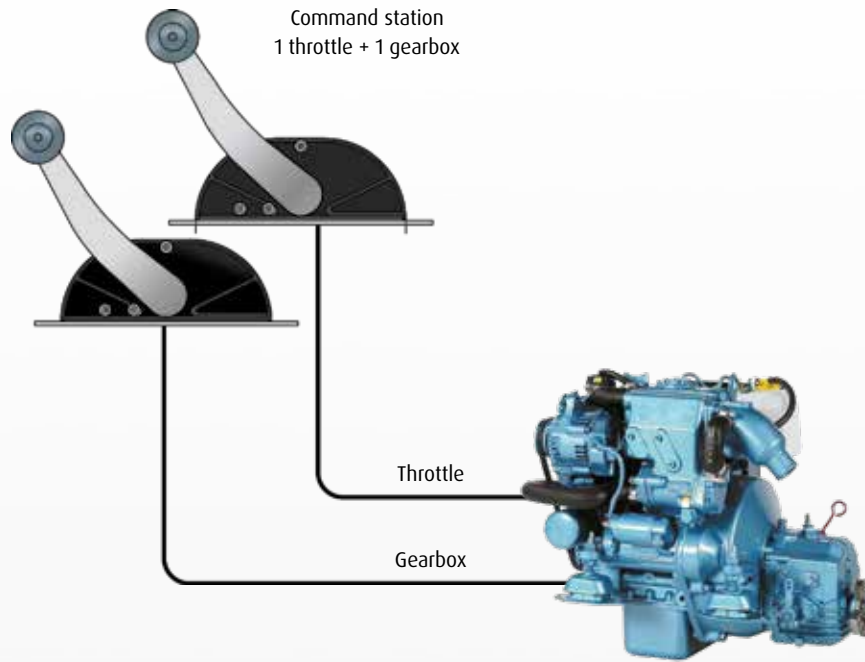

INSTALLATION SCHEME FOR TWO COMMAND STATIONS

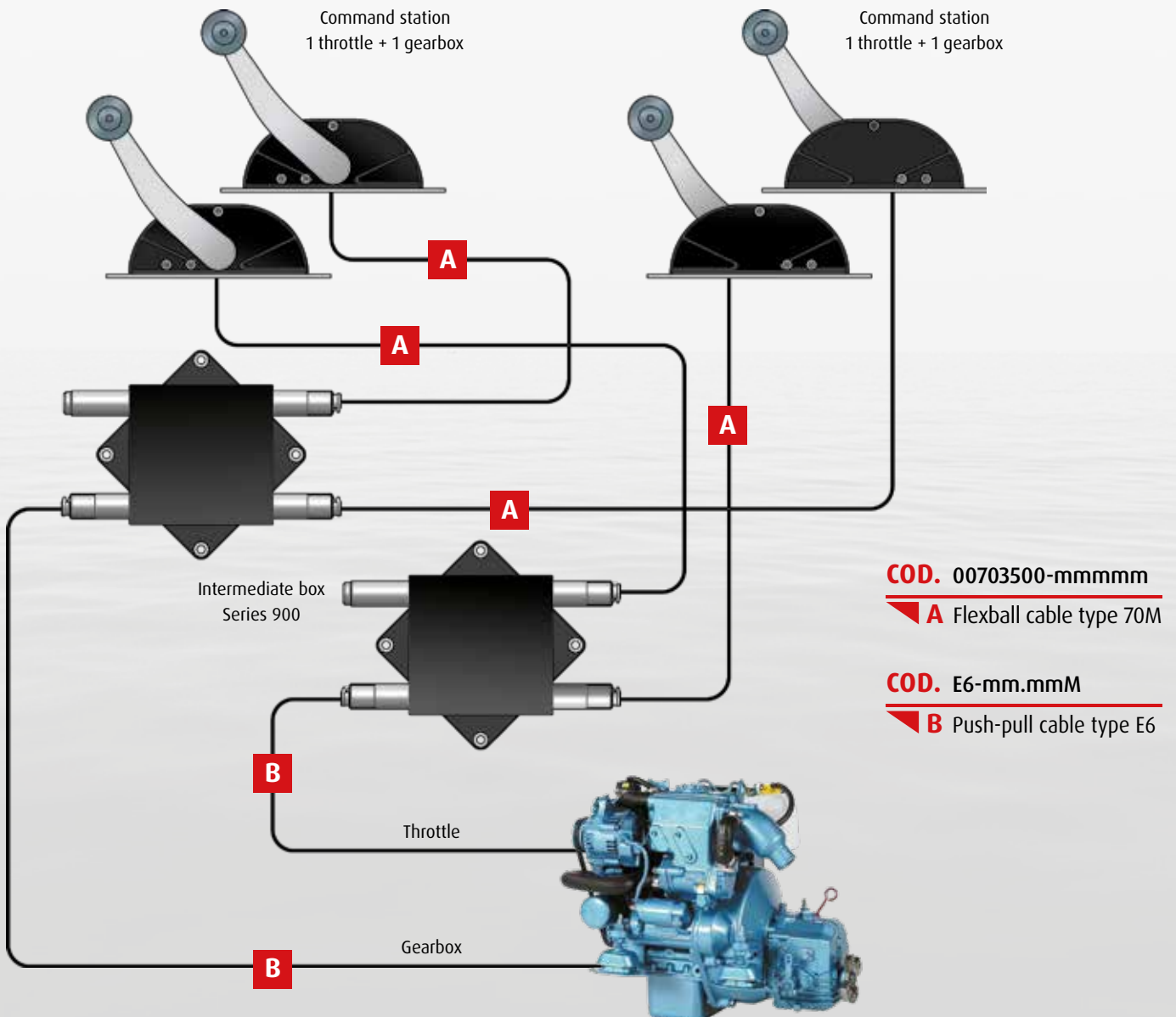

DIMENSIONS AND DRILLING MASKS

L = lever length

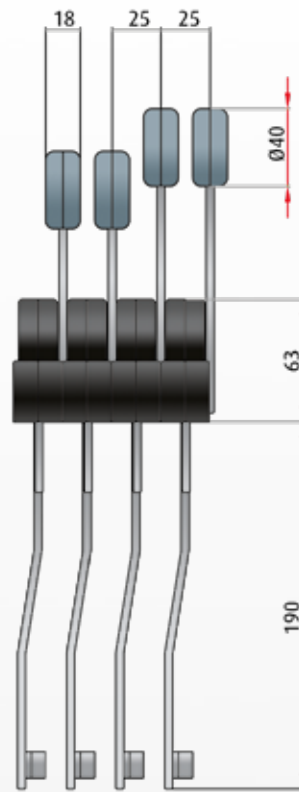
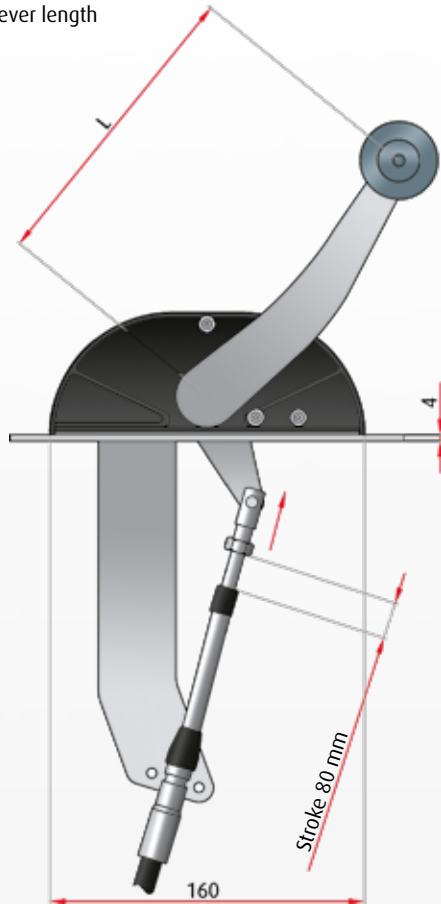

DRILLING MASK FOR TWO LEVERS

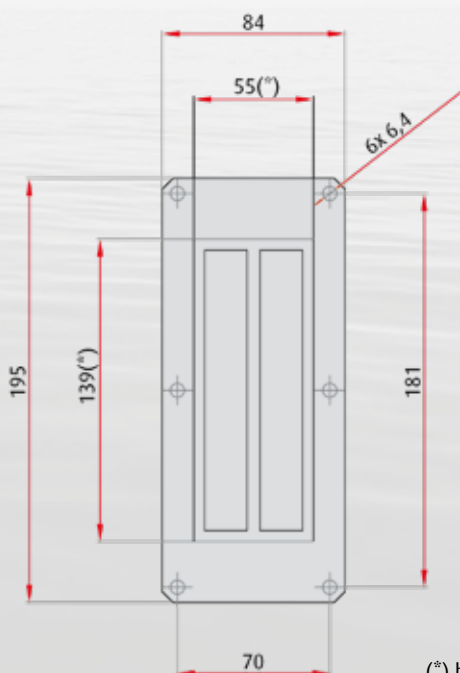

DRILLING MASK FOR FOUR LEVERS

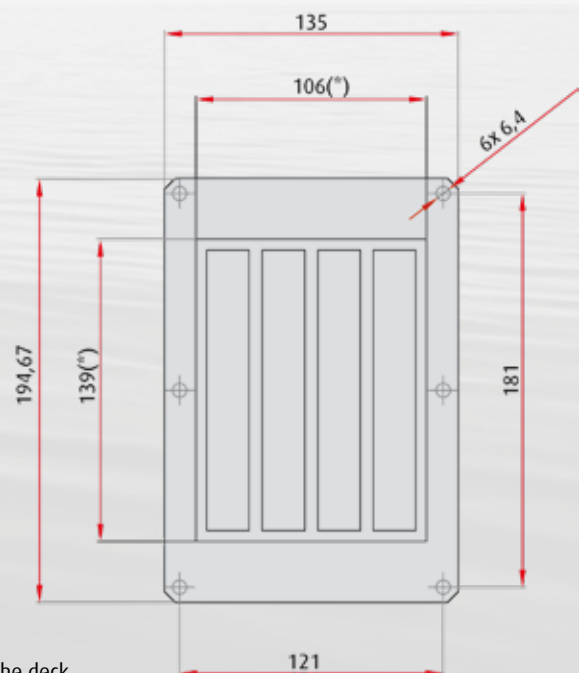

(*) hole to be cut to on the deck

590

Mechanical control



- Lever mixed left, available with interlock
- 1 throttle + 1 gearbox



- Lever double throttle



- Lever mixed right, available with interlock
- 1 throttle + 1 gearbox



- Lever double gearbox

TECHNICAL FEATURES

It is a system with double lever for deck mounting with limited external dimensions and with a simple and modern style. All the mechanism is under the desk and it is available with interlock system between the throttle and

the gearbox. It is also available with an adjustable friction on both levers. The internal mechanism allows a serial connection between two command stations.

Material used: stainless steel.

DESCRIPTION	CODE
• Control lever Series 590 mixed right	0590-MDX-INOX
• Control lever Series 590 mixed right with interlock	0590-MDX-INT
• Control lever Series 590 mixed left	0590-MSN-INOX
• Control lever Series 590 mixed left with interlock	0590-MSN-INT
• Control lever Series 590 double throttle	0590-DGS-INOX
• Control lever Series 590 double gearbox	0590-DIN-INOX

INSTALLATION SCHEME WITH ONE COMMAND STATION

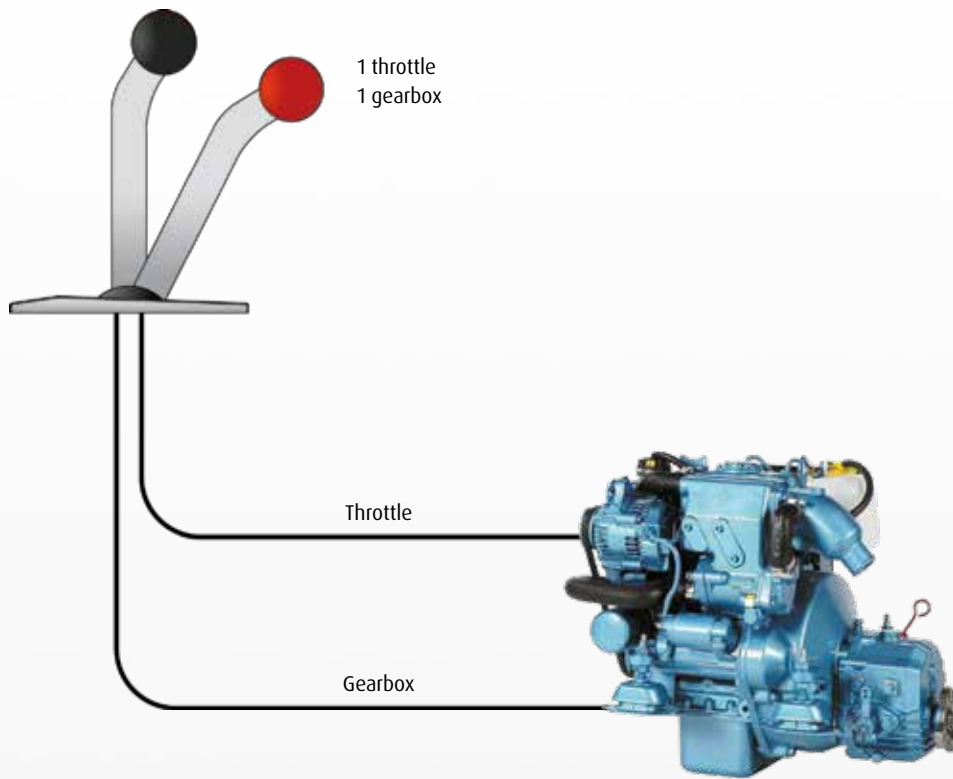

INSTALLATION SCHEME WITH TWO COMMAND STATIONS

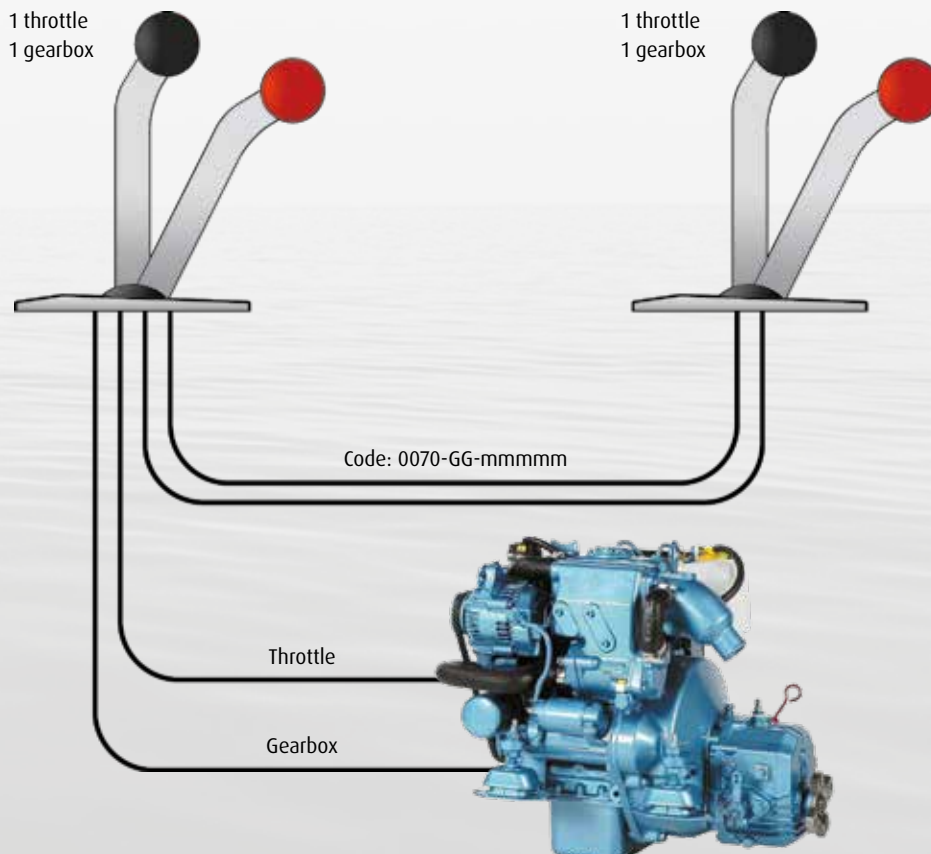

Note:
mmmmmm is the length in mm

DIMENSIONS, FOOTPRINTS AND DRILLING MASKS

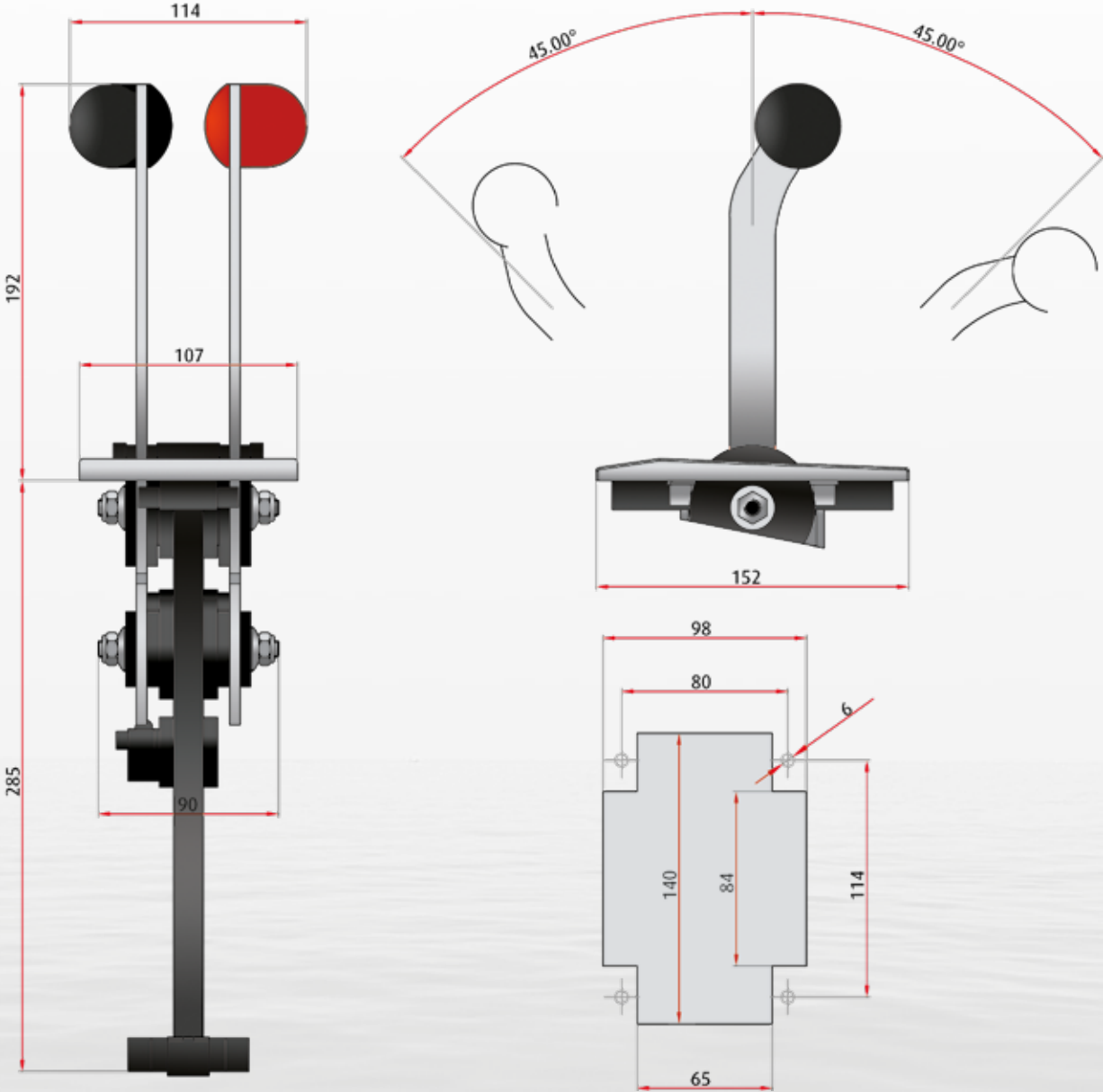

**MECHANICAL CABLES AVAILABLE
WITH SYSTEM SERIES 590**

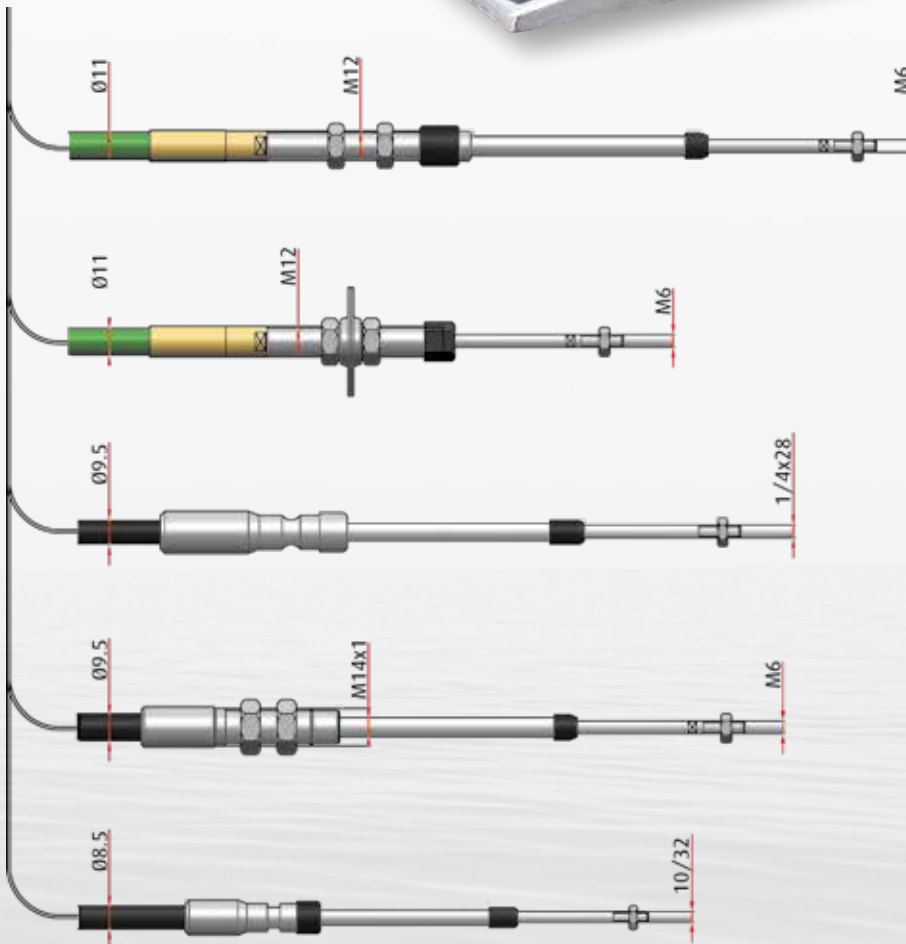

COD. 0070-FM-mmmmm

- Flexball cable type 70 with form M terminal

COD. 0070-FF-mmmmm

- Flexball cable type 70 with form F terminal

COD. E4-fff

- Push-pull cable E4

COD. E6-mm.mmM

- Push-pull cable E6

COD. E3-fff

- Push-pull cable E3

Note:

mmmmm is the length in mm

Example: Flexball 70 L=4 m → 0070-GF-04000

mm.mm is the length in meters

Example: E6 L=4,5 m → E6-04.50M

fff is the length in feet

Example: E3 L=10 feet → E3-10F

595

Mechanical control

Material used is a combination of aluminum and stainless steel parts. It is an extremely robust and reliable dual lever control for deck mounting. All the mechanism is under the desk and it is available with interlock system between the throttle and the gearbox. The internal mechanism allows a serial connection between two command stations. It has been designed for heavy application such as fishing and working boats. This control is compatible with Flexball cables type 70 G shape, push-pull cables type E4 and E3.

DESCRIPTION	CODE
• Control lever 595 series	0595
• Control lever 595 series with interlock	0595-INT



**MECHANICAL CABLES AVAILABLE
WITH CONTROL SERIES 595**

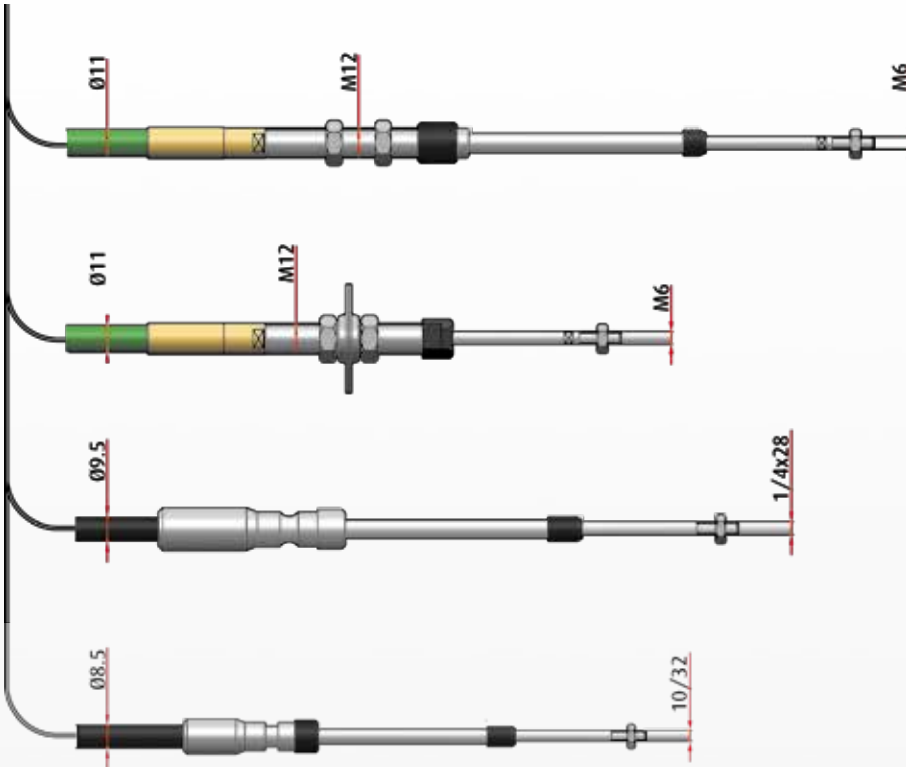

COD. 0070-GM-mmmm

- Flexball cable type 70 with form M terminal

COD. 0070-GF-mmmm

- Flexball cable type 70 with form F terminal

COD. E4-fff

- Push-pull cable E4

COD. E3-fff

- Push-pull cable E3

Note:

mmmm is the length in mm

Example: Flexball 70 L=4 m → 0070-GF-04000

mm.mm is the length in meters

Example: E6 L=4,5 m → E6-04.50M

fff is the length in feet

Example: E3 L=10 feet → E3-10F

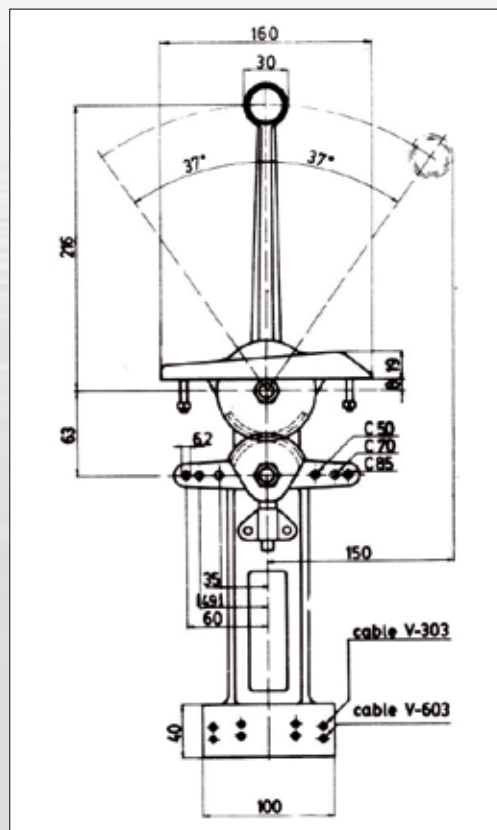
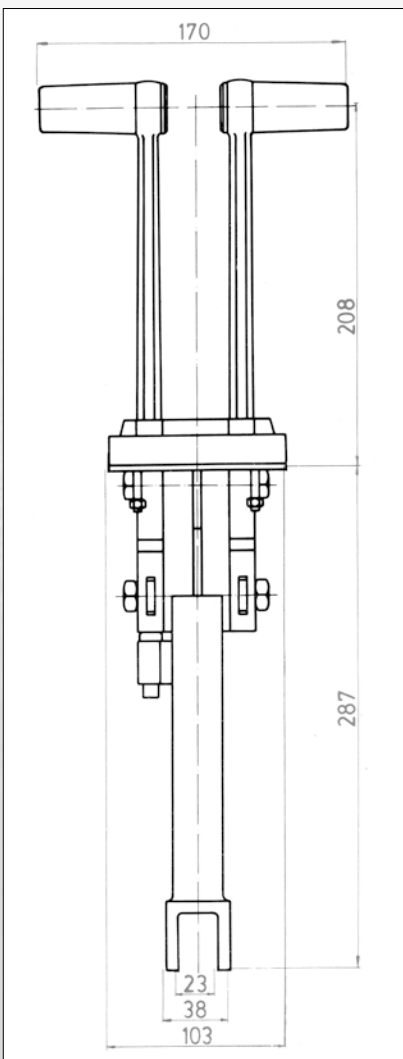

E95

Marine application

This is a series of control levers with robust and essential design, based on rack and pinion mechanism, are indicated for heavy duty applications. Control levers Series E95 are suitable to command winches and hydraulic pumps



TECHNICAL FEATURES

It is possible to connect either push-pull or Flexball cables.
Different way of fixing are available: either wall or deck mounting.

- Maximum stroke: 85 mm
- Maximum working load: 120 kg
- Lever ratio: 7,3:1.

It is available with or without adjustable friction, with fix or oscillating command lever.

DIMENSIONS

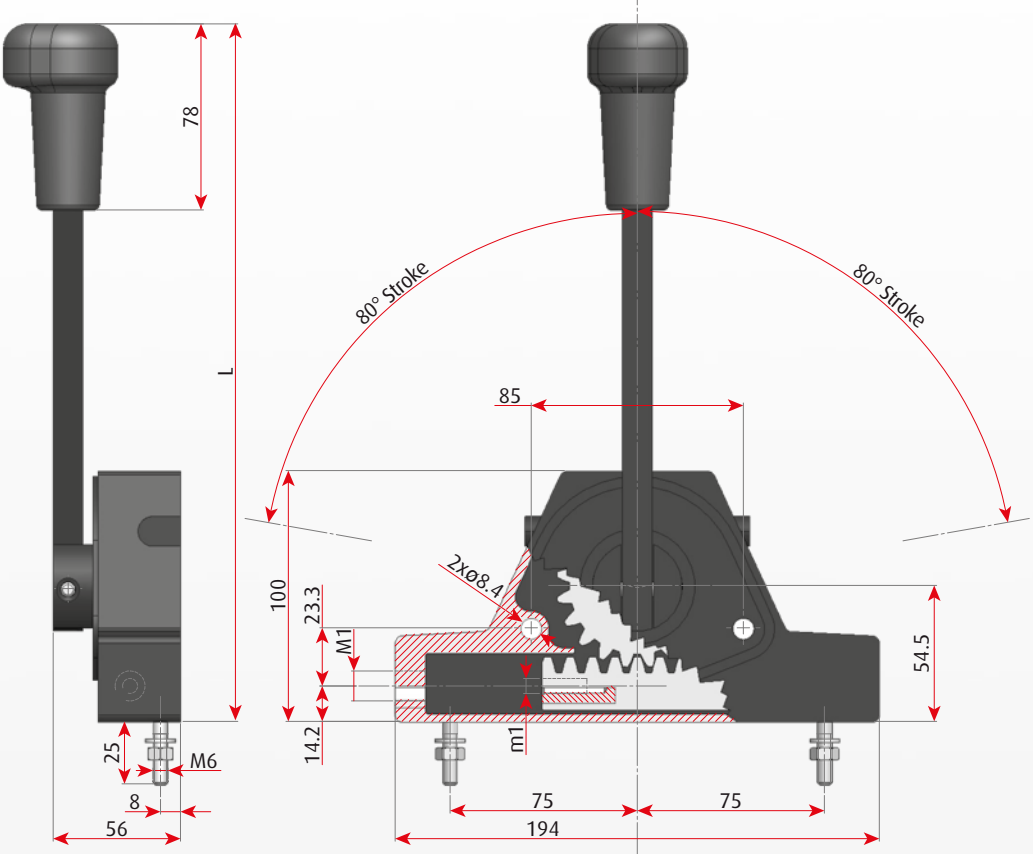

900

Marine application

This is a series of control levers with robust and essential design, based on a rack and pinion mechanism, indicated for heavy duty applications



STROKE	A	B	C
50	90	110	200
70	110	130	240
100	140	152	292
125	168	177	342
150	190	202	392

Control levers Series 900 are suitable to command winches, very heavy gearboxes, big and small cranes.

Control lever Series 900 are available with single lever (one cable can be connected), with single lever + locking device, with two levers (two cables can be connected) and with two levers + locking device.

DIMENSIONS

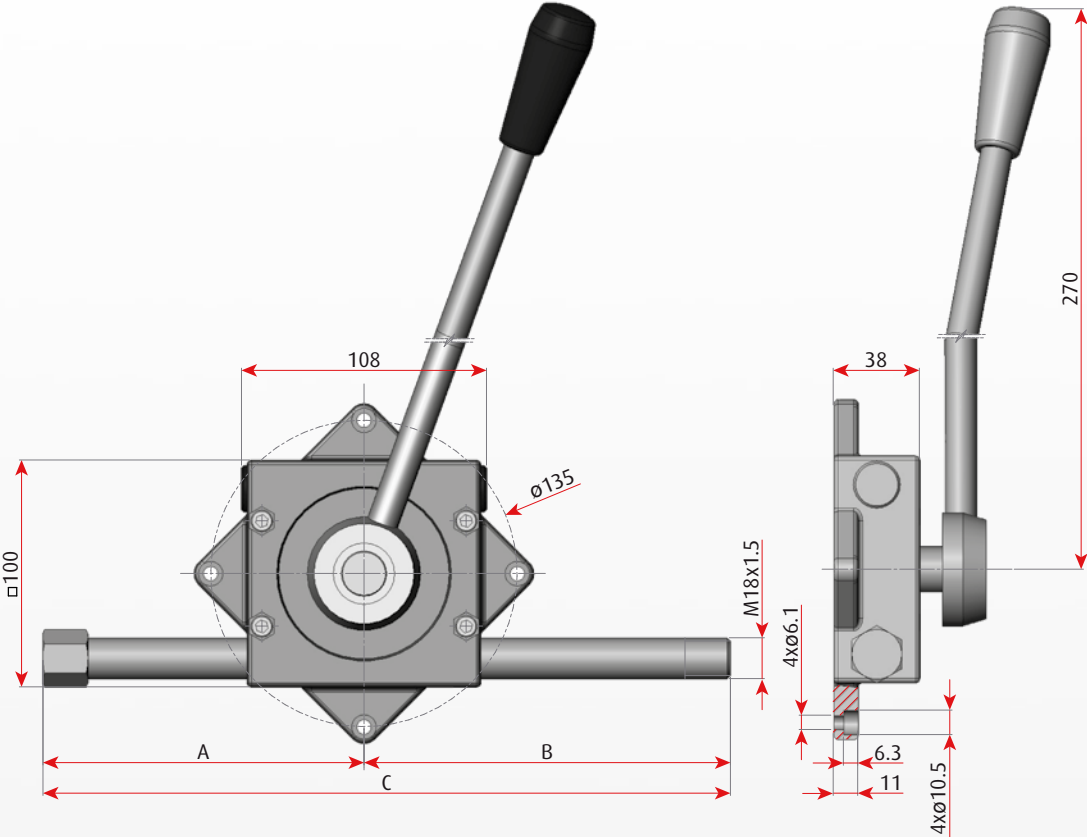



3



Electronic
Controls

4000

Electronic control

▼ Modular control for single and side by side mounting



- Suitable for all types of engines
- Easy mounting
- Reliable
- Precise
- Simple
- Reactive

DIMENSIONS

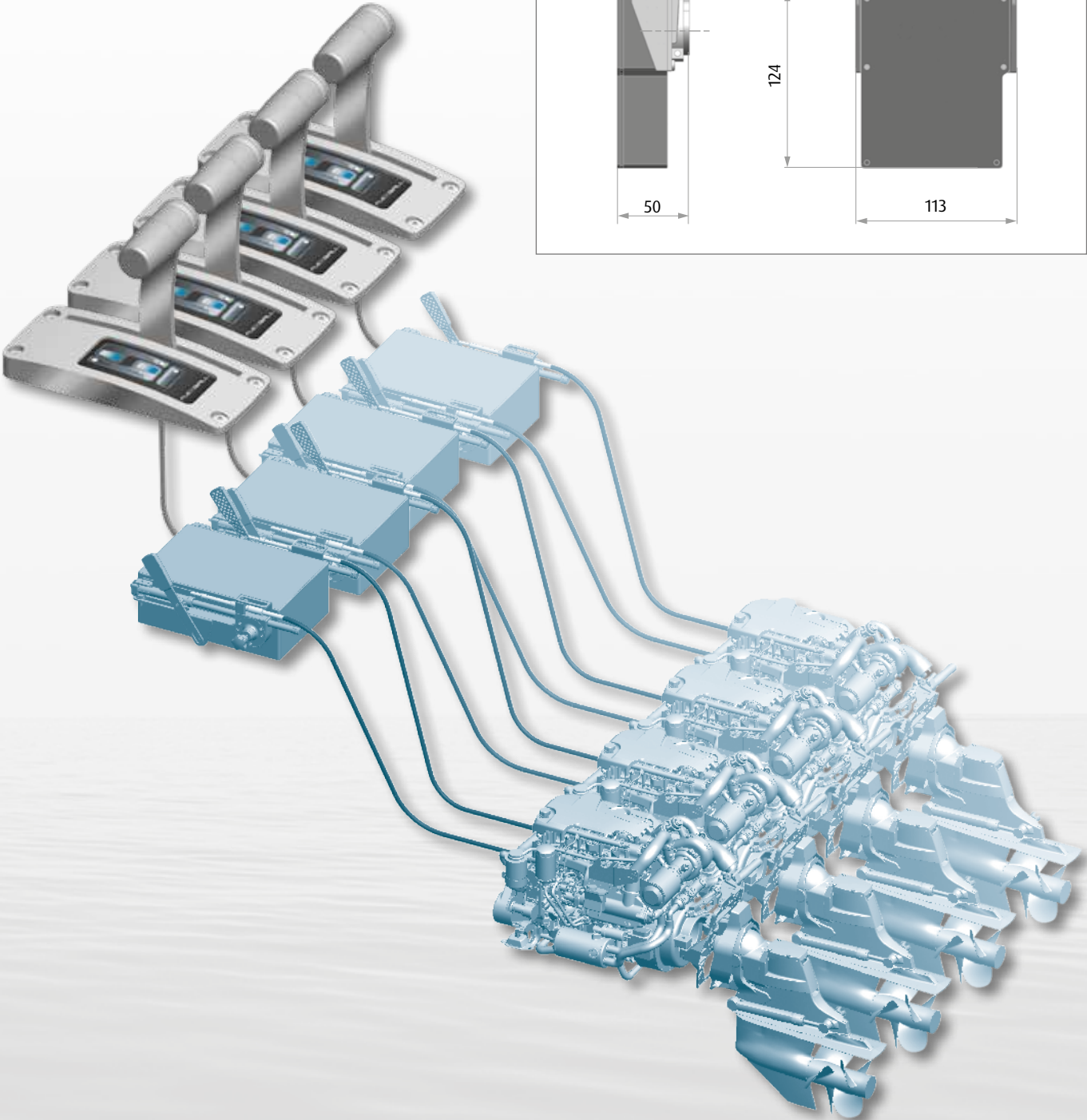
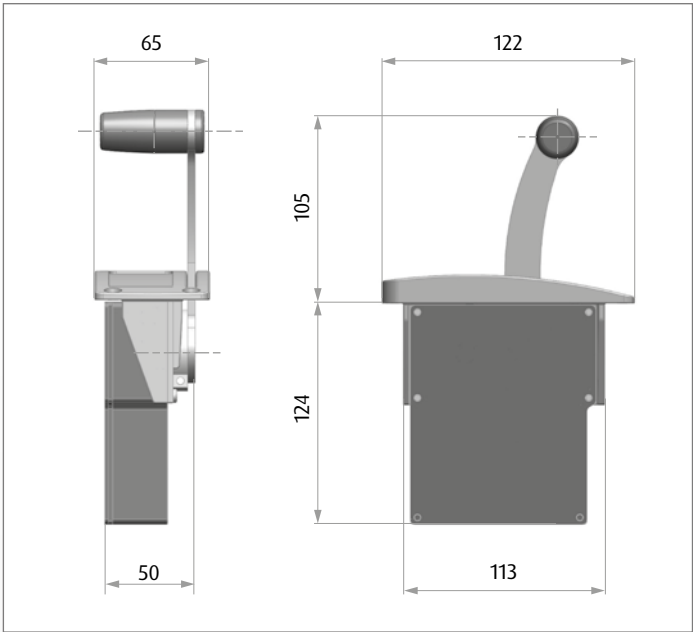

4000 Electric

Make your navigation greener

Your electric motor has never been so easy to control

Enjoy the new Flexball electronic control



- Suitable for all types of electric motors
- Easy mounting
- Reliable
- Precise
- Simple
- Reactive

DIMENSIONS

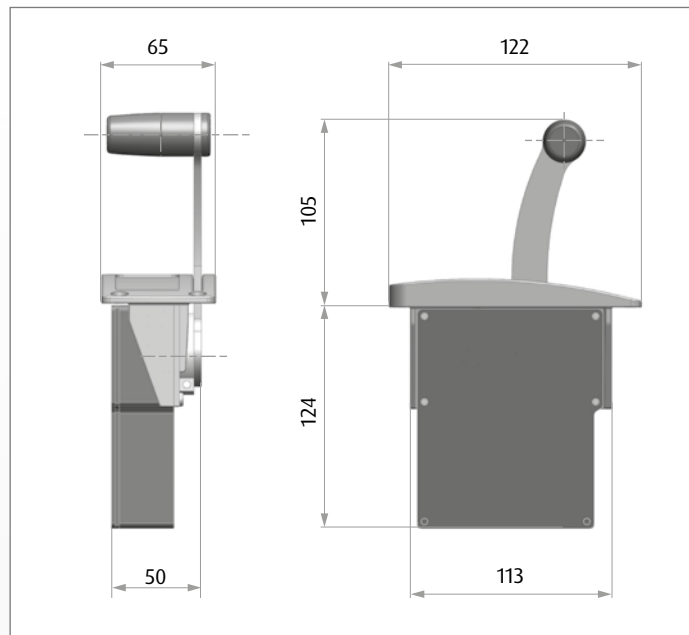

4000 ELECTRIC



MOTOR CONTROLLER

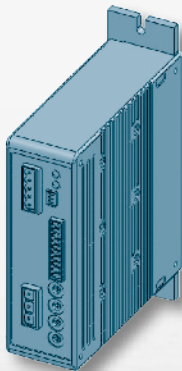

ELECTRIC MOTOR

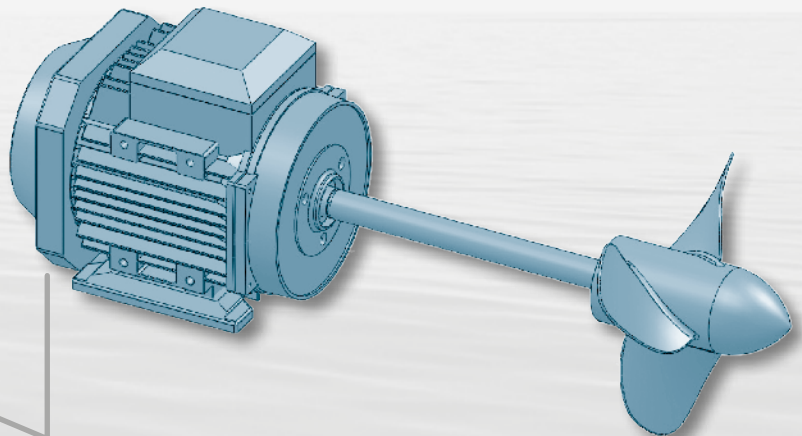

- Power supply from 9 to 32 Vdc
- Voltage, current or CANBus signals towards the motor controller
- 3 relay output free programmable, typically used for Forward, Reverse and Neutral commands

4100 Electric

Make your navigation greener

Your electric motor has never been so easy to control

Enjoy the new Flexball electronic control



4102 dual motor deck mounting

4101 Single motor deck mounting



4103 Single motor side mounting

- Suitable for all types of electric motors
- Easy mounting
- Reliable
- Precise
- Simple
- Reactive

4101

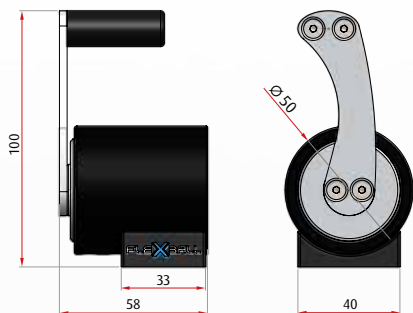

4102

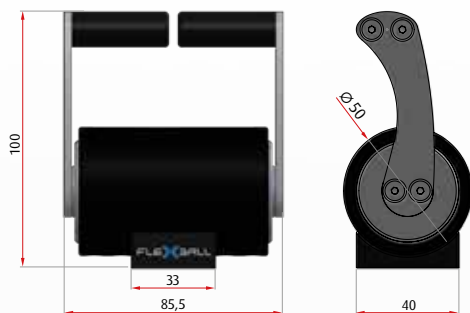

4103

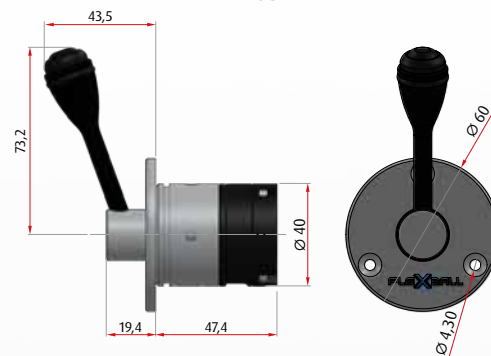

4100 ELECTRIC



MOTOR CONTROLLER

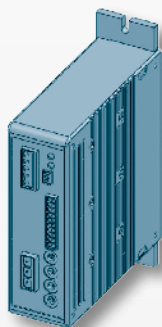

ELECTRIC MOTOR

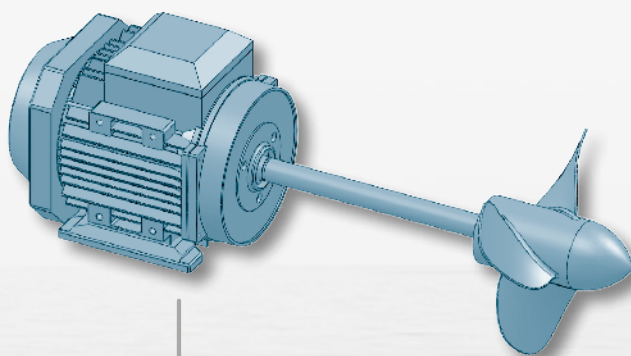

- Power supply from 9 to 32 Vdc
- Voltage signal towards the motor controller

4200

Side mounting electronic control

Make your navigation easier

Enjoy the new Flexball electronic control



- Suitable for all mechanical and electronic motors
- Safe (two operations to allow shifting from neutral)
- Trim option
- Easy mounting
- Reliable, precise, reactive
- Stainless steel made

DIMENSIONS

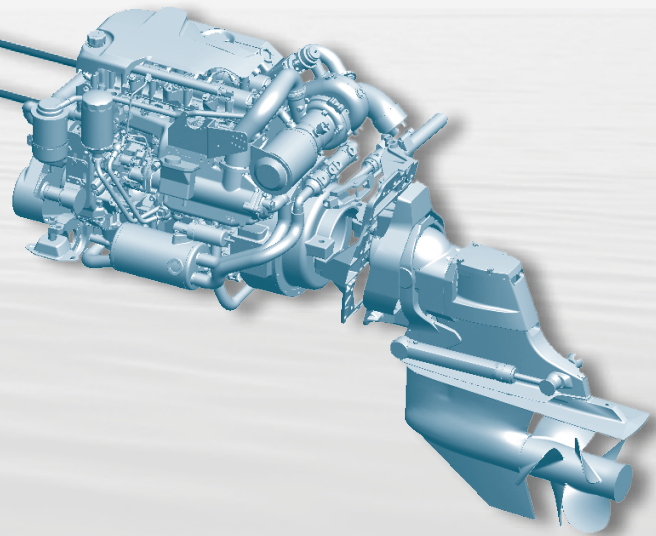
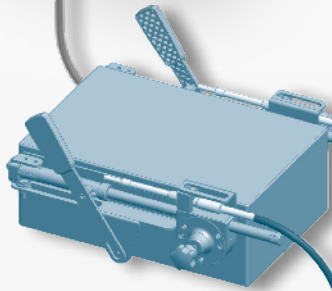
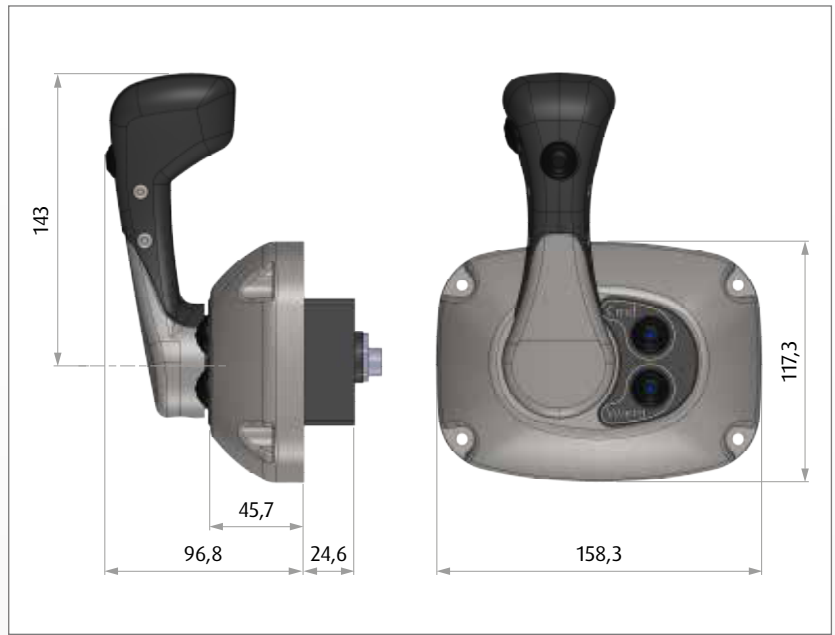

4200 Electric

Make your navigation greener

Your electric motor has never been so easy to control

Enjoy the new Flexball electronic control



- Suitable for all types of electric motors
- Easy mounting
- Reliable
- Precise
- Simple
- Reactive

DIMENSIONS

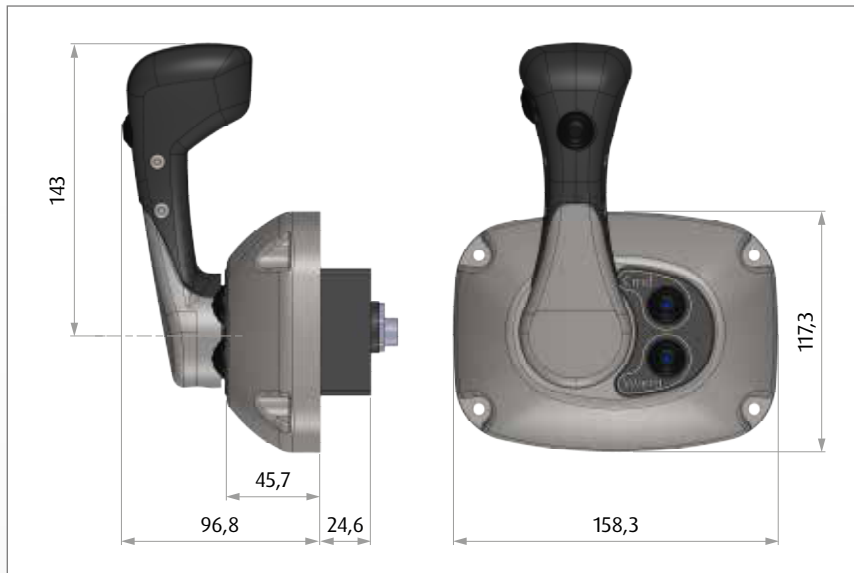

4200 ELECTRIC



MOTOR CONTROLLER

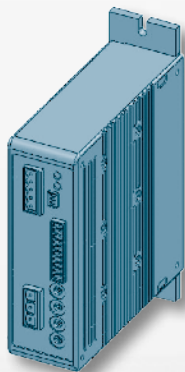

ELECTRIC MOTOR

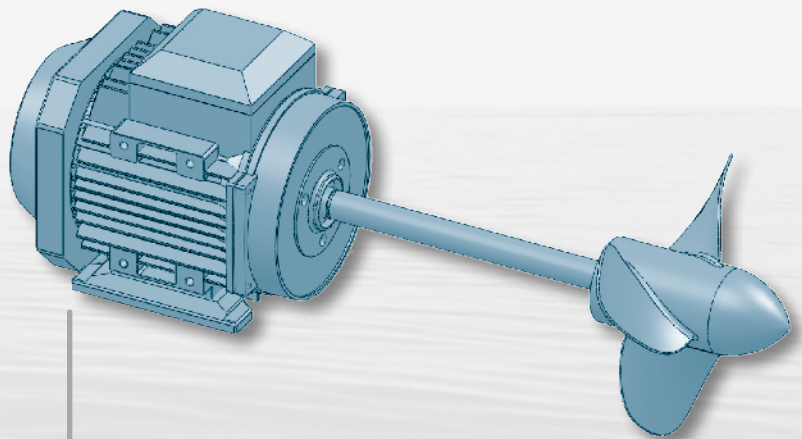

- Power supply from 9 to 32 Vdc
- Voltage, current or CANBus signals towards the motor controller
- 3 relay output free programmable, typically used for Forward, Reverse and Neutral commands

4500

Electronic control

Electronic control systems Series 4500 combine mechatronic solutions and digital communication technologies which permit to build modular systems, flexible, reliable and easy to install



Just a few devices create a complete electronic control system. The electronic system fundamentally consists of 4 elements which vary in amount and type, depending on installation requirements:

- control stations
- actuators
- data transmission cables to connect together actuators and control stations
- cables between actuator and motor and between actuator and gearbox.

The link between the various devices is via a simple 4-pin cable that carries all the information thru digital CANBus communication.

In case of motors with mechanical interface, push-pull cables transfer the motion from the actuators to the throttle on the motor and on the gearbox.

In the case of motors and gearboxes with electronic interface, a simple electrical wire performs their connection to the actuator. On all Flexball electronic control systems can be mounted lever Series 4500.

The systems are configured to interface to different types of motors and gearboxes and their possible combinations.

MOTORS COMPATIBILITY

- Voltage: Cummins, Detroit Diesel, Scania, FNM, Lombardini, Deutz Vetus
- 4-20 mA current: MAN, MTU, Isotta Fraschini
- PWM: Caterpillar, Scania.

KEY FEATURES

- With up to 3 control stations in the basic version, the system can be extended up to 7 control stations
- Fast Start-up Mode Function
- Synchro function that can be activated either in neutral or when sailing
- Trolling control
- Trim/Flap and Synchro Trim/Flap function
- Starting inhibition if the gear isn't in neutral
- Advanced functions for fast and safe commissioning
- Interface to frequency converters in hybrid propulsion systems
- Programmable delays at clutch in or clutch out
- Emergency safety devices directly on the actuator, in the case of systems with mechanical interface.

MAIN FEATURES

- Electronic control system in drive by wire technology
- Maximum distance between deck and engine room can be more than 60 meters
- Fast and easy installation
- EMC and CE Certified
- Operation with instant plug and play
- Limited number of components
- Digital Data Transmission
- Setting of operating parameters either via keypad or via PC.

TECHNICAL FEATURES

- Supply voltage from 9.0 to 32 Vdc (multi-voltage supply)
- Max input current: 5 A
- Current at idle: 0.5 A
- Operating temperature: -10 to + 85 °C
- Mechanical generated force at nominal conditions: 250 N (25 kg) with absorption of 1.5 A
- Maximum generated force: 450 N (45 kg) with absorption of 5 A and for a time less than 1 second
- Gearbox stroke - forward: it can be set between 5 and 40 mm
- Gearbox stroke - reverse: it can be set between 5 and 40 mm
- Maximum throttle stroke: 80 mm.

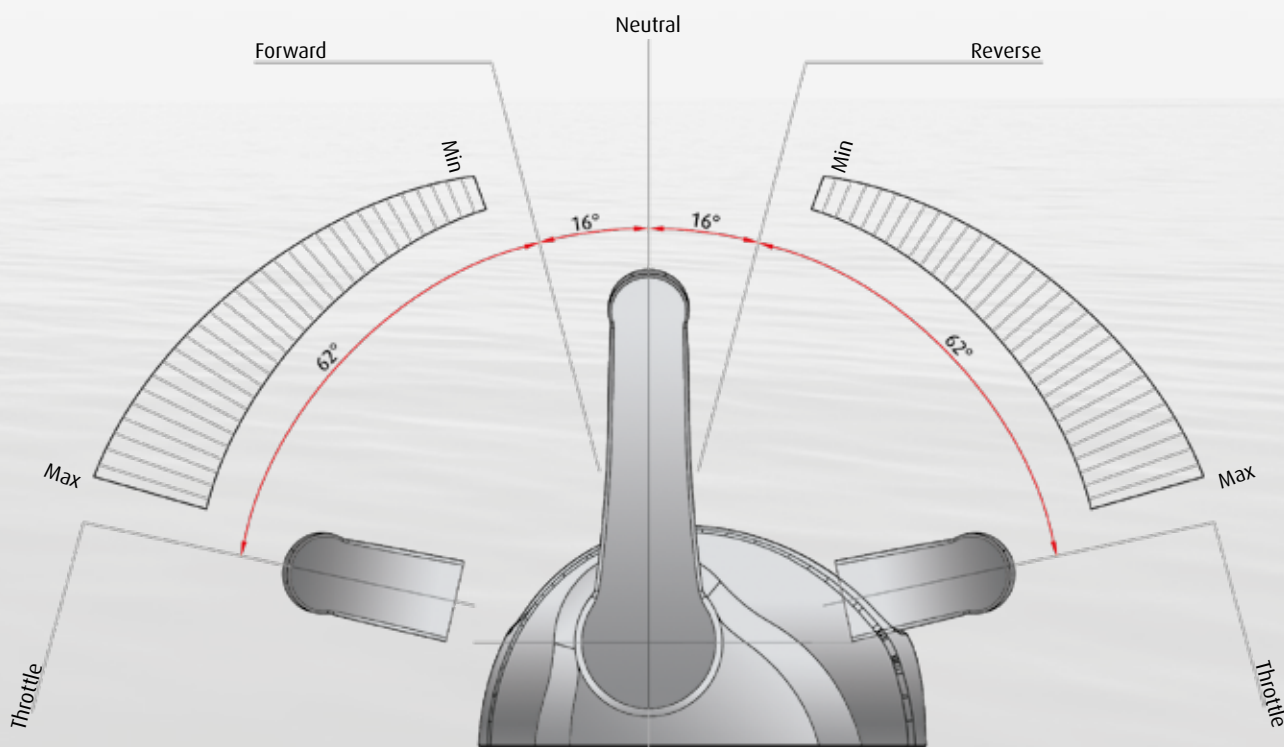

The diagram below represents a system configured with:

- n. 2 actuators • n. 3 control stations
- data transmission cables between levers, lever and actuator and between actuators
- motor and gearbox connection cables which, depending on the type of motor and gearbox, can be mechanical or electronic.

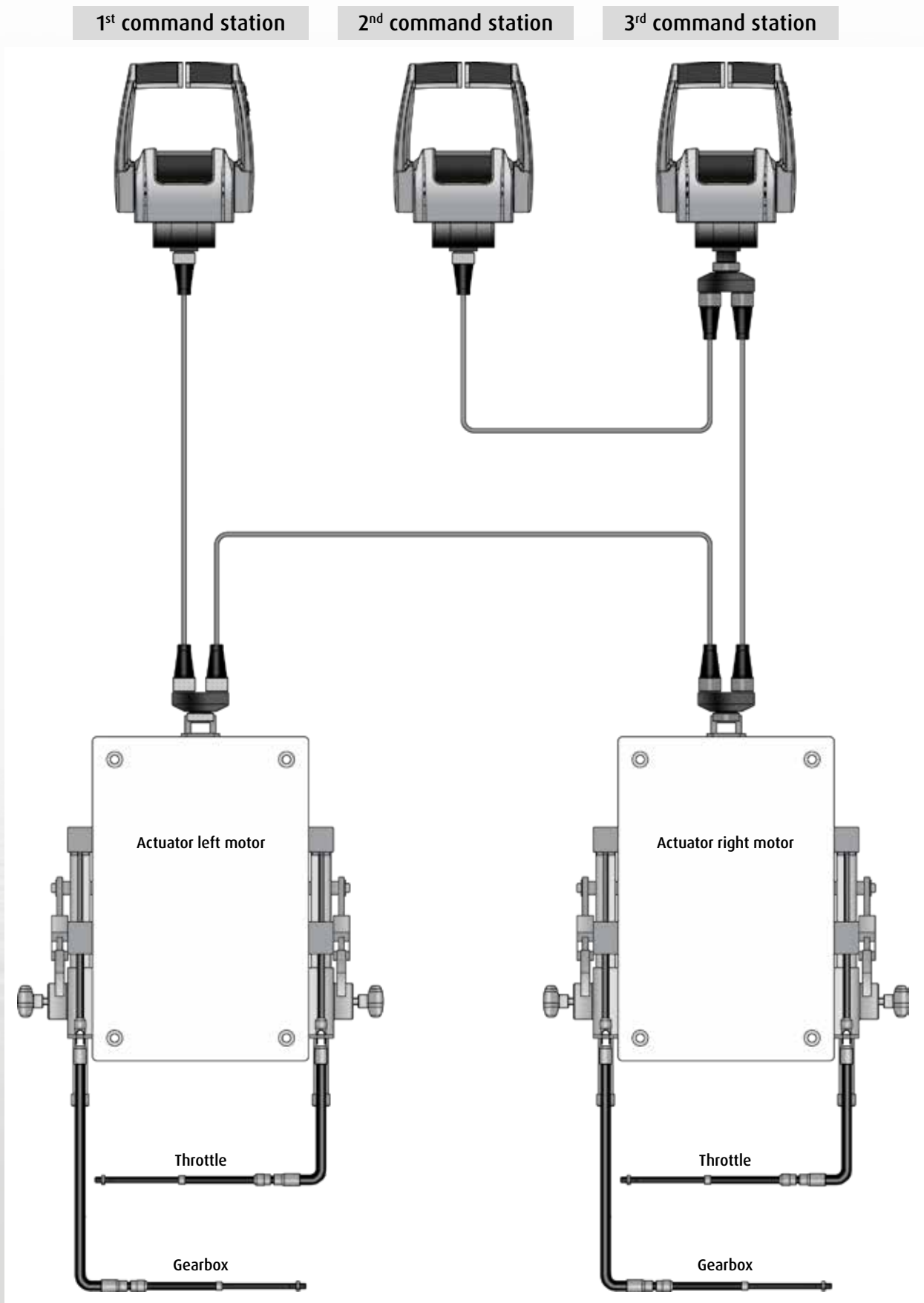

SYSTEM CONFIGURATIONS

The system types listed below always refer to the diagram on the previous page and are based on the following conditions:

- The distance between the various devices and specifically the distance between levers, lever and actuator or between actuators is = 7.5 m; in case you need longer cables (especially between the deck and the engine room) they must be defined when ordering.
- All electrical wirings to connect the actuator to the motor and the actuator to the gearbox, are as standard 3 meters. If longer cables were required, it must be communicated when ordering. There are specific cablings for mo-

tors like FNM, FPT, Nanni Diesel, Vetus, etc. In this case you must communicate the specific type of motor you need to command.

The system configurations are classified according to the possible combinations of:

- motor types
- gearbox types
- number of engines
- number of levers
- options.

The following table lists all the types of electronic systems. The most common ones are highlighted in gray.

SYSTEM TYPE	ID
• Mechanical throttle and mechanical gearbox	MM
• Electronic voltage throttle and mechanical gearbox	VM
• CANBus throttle and mechanical gearbox	CM
• Electronic PWM throttle and mechanical gearbox	WM
• Electronic current throttle and mechanical gearbox	IM
• Mechanical throttle and electronic gearbox	ME
• Electronic voltage throttle and electronic gearbox	VE
• CANBus throttle and electronic gearbox	CE
• Electronic PWM throttle and electronic gearbox	WE
• Electronic current throttle and electronic gearbox	IE
• Electronic voltage throttle and trolling gearbox	VT
• CANBus throttle and trolling gearbox	CT
• Trim/Flap option	F
• Interface towards frequency converter on hybrid propulsion systems	T



Now it follows a list of complete system configurations. The prefix 4500 defines the type of control lever to be mounted on the boat. For example, the 4500-MM22F indicates a system with two mechanical motors, two mechanical gearboxes, trim/flaps option and two control stations 4500 Series.

COD. MM Electronic control systems compatible with mechanical motors and mechanical gearboxes

TROTTLER MECHANICAL – GEARBOX MECHANICAL			
	WITHOUT TRIM/FLAP	WITH TRIM/FLAP	WITH HYBRID MOTOR OPTION
• 1 motor, 1 command station	4500-MM11	4500-MM11F	4500-MM11H
• 1 motor, 2 command stations	4500-MM12	4500-MM12F	4500-MM12H
• 2 motors, 1 command station	4500-MM21	4500-MM21F	4500-MM21H
• 2 motors, 2 command stations	4500-MM22	4500-MM22F	4500-MM22H
• 2 motors, 3 command stations	4500-MM23	4500-MM23F	4500-MM23H

COD. VM Electronic control systems compatible with electronic voltage motors Hyundai, Deutz, FNM, Vetus, Nanni Diesel, Lombardini, Cummins, etc. and mechanical gearboxes

TROTTLER ELECTRONIC (V) – GEARBOX MECHANICAL			
	WITHOUT TRIM/FLAP	WITH TRIM/FLAP	WITH HYBRID MOTOR OPTION
• 1 motor, 1 command station	4500-VM11	4500-VM11F	4500-VM11H
• 1 motor, 2 command stations	4500-VM12	4500-VM12F	4500-VM12H
• 2 motors, 1 command station	4500-VM21	4500-VM21F	4500-VM21H
• 2 motors, 2 command stations	4500-VM22	4500-VM22F	4500-VM22H
• 2 motors, 3 command stations	4500-VM23	4500-VM23F	4500-VM23H

COD. CM Electronic control systems compatible with CANBus motors FPT, Nanni Diesel, Toyota, VM, etc. and mechanical gearboxes

TROTTLER CANBUS – GEARBOX MECHANICAL		
	WITHOUT TRIM/FLAP	WITH TRIM/FLAP
• 1 motor, 1 command station	4500-CM11	4500-CM11F
• 1 motor, 2 command stations	4500-CM12	4500-CM12F
• 2 motors, 1 command station	4500-CM21	4500-CM21F
• 2 motors, 2 command stations	4500-CM22	4500-CM22F
• 2 motors, 3 command station	4500-CM23	4500-CM23F

COD. WM Electronic control systems compatible with electronic PWM motors Caterpillar, Deutz, Scania, etc. and mechanical gearboxes

TROTTLER PWM – GEARBOX MECHANICAL		
	WITHOUT TRIM/FLAP	WITH TRIM/FLAP
• 1 motor, 1 command station	4500-WM11	4500-WM11F
• 1 motor, 2 command stations	4500-WM12	4500-WM12F
• 2 motors, 1 command station	4500-WM21	4500-WM21F
• 2 motors, 2 command stations	4500-WM22	4500-WM22F
• 2 motors, 3 command stations	4500-WM23	4500-WM23F

COD. IM Electronic control systems compatible with electronic current motors Caterpillar, Deutz, Isotta Fraschini, etc. and mechanical gearboxes

TROTTLER CURRENT (I) – GEARBOX MECHANICAL		
	WITHOUT TRIM/FLAP	WITH TRIM/FLAP
• 1 motor, 1 command station	4500-IM11	4500-IM11F
• 1 motor, 2 command stations	4500-IM12	4500-IM12F
• 2 motors, 1 command station	4500-IM21	4500-IM21F
• 2 motors, 2 command stations	4500-IM22	4500-IM22F
• 2 motors, 3 command stations	4500-IM23	4500-IM23F

COD. ME Electronic control systems compatible with mechanical motors and electronic solenoid gearboxes

TROTTLER MECHANICAL – GEARBOX ELECTRONIC			
	WITHOUT TRIM/FLAP	WITH TRIM/FLAP	WITH HYBRID MOTOR OPTION
• 1 motor, 1 command station	4500-ME11	4500-ME11F	4500-ME11H
• 1 motor, 2 command stations	4500-ME12	4500-ME12F	4500-ME12H
• 2 motors, 1 command station	4500-ME21	4500-ME21F	4500-ME21H
• 2 motors, 2 command stations	4500-ME22	4500-ME22F	4500-ME22H
• 2 motors, 3 command stations	4500-VM23	4500-VM23F	4500-VM23H

COD. VE Electronic control systems compatible with electronic voltage motors Hyundai, Deutz, FNM, Vetus, Nanni Diesel, Lombardini, Cummins, etc. and electronic solenoid gearboxes

TROTTL E ELECTRONIC (V) – GEARBOX ELECTRONIC			
	WITHOUT TRIM/FLAP	WITH TRIM/FLAP	WITH HYBRID MOTOR OPTION
• 1 motor, 1 command station	4500-VE11	4500-VE11F	4500-VE11H
• 1 motor, 2 command stations	4500-VE12	4500-VE12F	4500-VE12H
• 2 motors, 1 command station	4500-VE21	4500-VE21F	4500-VE21H
• 2 motors, 2 command stations	4500-VE22	4500-VE22F	4500-VE22H
• 2 motors, 3 command stations	4500-VE23	4500-VE23F	4500-VE23H

COD. CE Electronic control systems compatible with CANBus motors FPT, Nanni Diesel, Toyota, VM, etc. and electronic solenoid gearboxes

TROTTL E CANBUS – GEARBOX ELECTRONIC			
	WITHOUT TRIM/FLAP	WITH TRIM/FLAP	WITH HYBRID MOTOR OPTION
• 1 motor, 1 command station	4500-CE11	4500-CE11F	4500-CE11H
• 1 motor, 2 command stations	4500-CE12	4500-CE12F	4500-CE12H
• 2 motors, 1 command station	4500-CE21	4500-CE21F	4500-CE21H
• 2 motors, 2 command stations	4500-CE22	4500-CE22F	4500-CE22H
• 2 motors, 3 command stations	4500-CE23	4500-CE23F	4500-CE23H

COD. WE Electronic control systems compatible with electronic PWM motors Caterpillar, Deutz, Scania, etc. and electronic solenoid gearboxes

TROTTL E PWM – GEARBOX ELECTRONIC		
	WITHOUT TRIM/FLAP	WITH TRIM/FLAP
• 1 motor, 1 command station	4500-WE11	4500-WE11F
• 1 motor, 2 command stations	4500-WE12	4500-WE12F
• 2 motors, 1 command station	4500-WE21	4500-WE21F
• 2 motors, 2 command stations	4500-WE22	4500-WE22F
• 2 motors, 3 command stations	4500-WE23	4500-WE23F

COD. IE Electronic control systems compatible with electronic current motors Caterpillar, Deutz, Isotta Fraschini, etc. and electronic solenoid gearboxes

TROTTLER CURRENT (I) – GEARBOX ELECTRONIC		
	WITHOUT TRIM/FLAP	WITH TRIM/FLAP
• 1 motor, 1 command station	4500-IE11	4500-IE11F
• 1 motor, 2 command stations	4500-IE12	4500-IE12F
• 2 motors, 1 command station	4500-IE21	4500-IE21F
• 2 motors, 2 command stations	4500-IE22	4500-IE22F
• 2 motors, 3 command stations	4500-IE23	4500-IE23F

COD. VT Electronic control systems compatible with electronic voltage motors Hyundai, Deutz, FNM, Vetus, Nanni Diesel, Lombardini, Cummins, etc. and trolling gearboxes

TROTTLER VOLTAGE (V) – GEARBOX TROLLING		
	WITHOUT TRIM/FLAP	WITH TRIM/FLAP
• 1 motor, 1 command station	4500-VT11	4500-VT11F
• 1 motor, 2 command stations	4500-VT12	4500-VT12F
• 2 motors, 1 command station	4500-VT21	4500-VT21F
• 2 motors, 2 command stations	4500-VT22	4500-VT22F
• 2 motors, 3 command stations	4500-VT23	4500-VT23F

COD. CT Electronic control systems compatible with CANBus motors FPT, Nanni Diesel, Toyota, VM, etc. and trolling gearboxes

TROTTLER CANBUS – GEARBOX TROLLING		
	WITHOUT TRIM/FLAP	WITH TRIM/FLAP
• 1 motor, 1 command station	4500-CT11	4500-CT11F
• 1 motor, 2 command stations	4500-CT12	4500-CT12F
• 2 motors, 1 command station	4500-CT21	4500-CT21F
• 2 motors, 2 command stations	4500-CT22	4500-CT22F
• 2 motors, 3 command stations	4500-CT23	4500-CT23F

DATA TRANSMISSION CABLES CANBUS

DESCRIPTION	CODE
• Length m 3	3500.33-03000
• Length m 5	3500.33-05000
• Length m 7.5	3500.33-07500
• Length m 10	3500.33-10000
• Length m 15	3500.33-15000
• Length m 20	3500.33-20000
• Length m 25	3500.33-25000
• Extension cable male/female m 30	3500.39-30000
• CANBus "T" splitter	N-85E010003



4500 Electric

Make your navigation greener

Your electric motor has never been so easy to control

Enjoy the new Flexball electronic control



- Suitable for all types of electric motors
- Easy mounting
- Reliable
- Precise
- Simple
- Reactive

DIMENSIONS

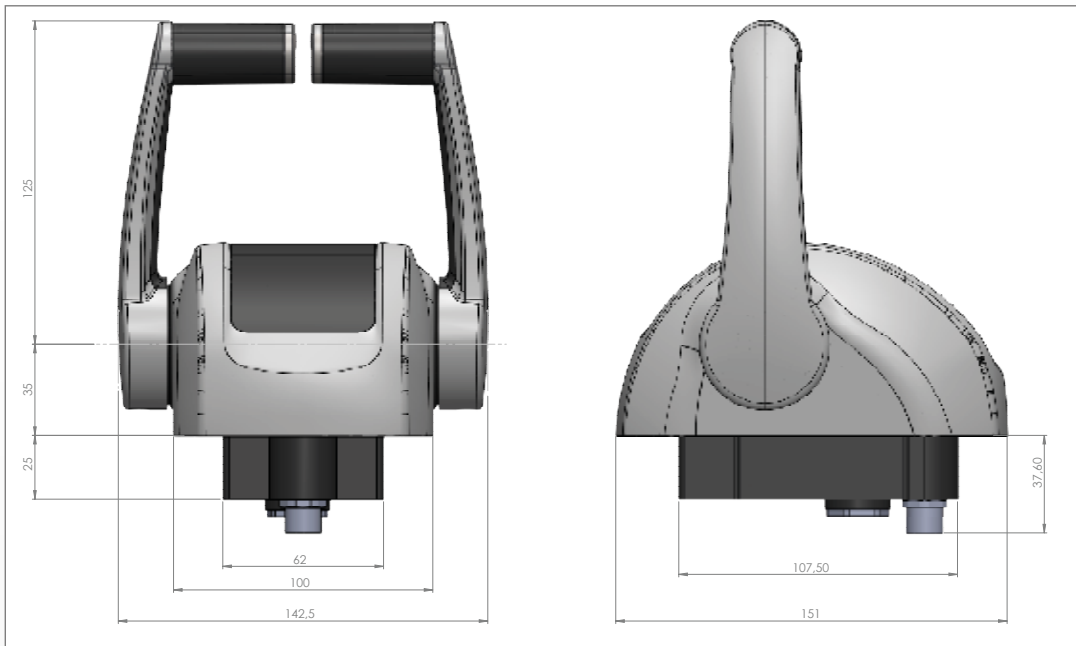

4500 ELECTRIC



MOTOR CONTROLLER

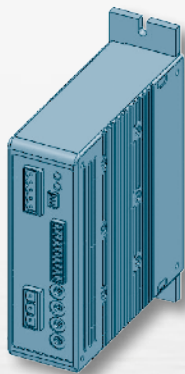

ELECTRIC MOTOR

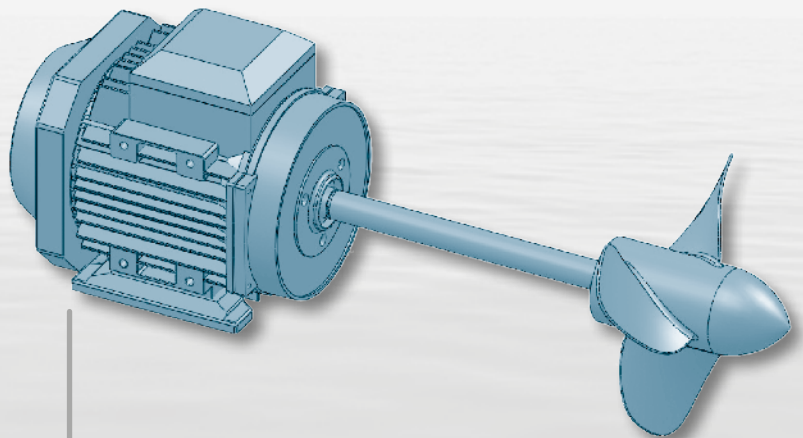

- Power supply from 9 to 32 Vdc
- Voltage, current or CANBus signals towards the motor controller
- 3 relay output free programmable, typically used for Forward, Reverse and Neutral commands

4500 TLC

Twin lever control

4500 TLC is a Twin Lever Control with split gear and throttle commands. As an extension of the 4500 electronic control system, it offers the same flexibility, modularity and ease of installation



- Pure AISI 316
- Fast and easy installation with plug and play functions
- Up to 60 meters between deck and engine room
- Free assignment of throttle and gear to each lever
- With or without interlock at speed direction change
- Long lever stroke for a precise speed setting (166 degrees)

SYSTEM CONFIGURATIONS

- The distance between the various devices and specifically the distance between levers, lever and actuator or between actuators is = 7.5 m; in case you need longer cables (especially between the deck and the engine room) they must be defined when ordering.
- All electrical wirings to connect the actuator to the motor and the actuator to the gearbox, are as standard 3 meters. If longer cables were required, it must be communicated when ordering. There are specific cablings for motors like FNM, FPT, Nanni Diesel, Vetus, Volkswagen, Hyundai, etc. In this case you must communicate the specific type of motor you need to command.

The system configurations are classified according to the possible combinations of:

- motor types
- gearbox types
- number of engines
- number of levers
- options.

The following table lists all the types of electronic systems. The most common ones are highlighted in gray.

SYSTEM TYPE	ID
• Mechanical throttle and mechanical gearbox	MM
• Electronic voltage throttle and mechanical gearbox	VM
• CANBus throttle and mechanical gearbox	CM
• Electronic PWM throttle and mechanical gearbox	WM
• Electronic current throttle and mechanical gearbox	IM
• Mechanical throttle and electronic gearbox	ME
• Electronic voltage throttle and electronic gearbox	VE
• CANBus throttle and electronic gearbox	CE
• Electronic PWM throttle and electronic gearbox	WE
• Electronic current throttle and electronic gearbox	IE
• Electronic voltage throttle and trolling gearbox	VT
• CANBus throttle and trolling gearbox	CT
• Trim/Flap option	F
• Interface towards frequency converter on hybrid propulsion systems	T

4500

Controllable pitch propeller / waterjet

▼ This system permits to control the engine speed (rpm) and tune the propeller pitch or the waterjet



The command station is a «dual lever control»: one lever (red) controls the engine speed and the second lever (black) controls the propeller pitch or the waterjet. This allows an accurate and precise fine tuning of the boat speed.

SYSTEM CONFIGURATION

This system is composed by:

- one Actuator Box to control the engine throttle and the propeller pitch control or the waterjet;
- one Command Station with two levers, one for the throttle control (red color) and the other for the propeller pitch or waterjet control (black color)
- a CANBus cable to connect the Actuator Box to the Command Station, whose length is in the range 3m 200m.

The system, once enabled, permits to “drive by wire” both the speed and the propeller pitch or the waterjet.

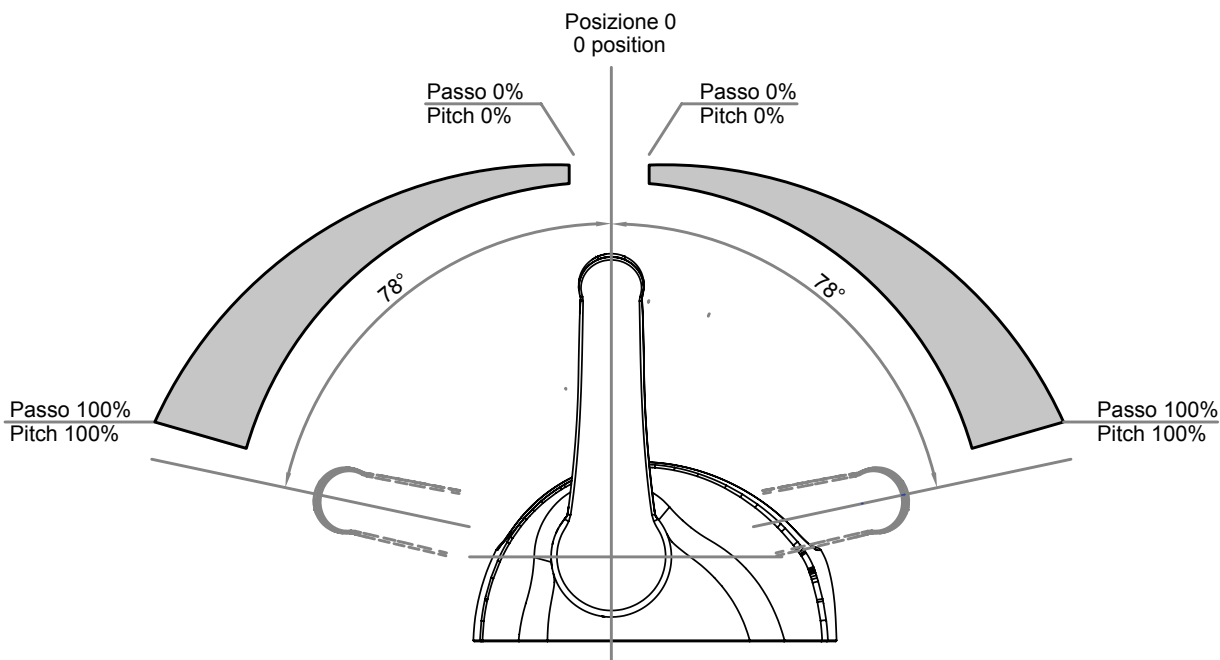

Funzionamento leva di comando del passo dell'elica (colore nero)
Functioning of the pitch propeller waterjet command lever (black)

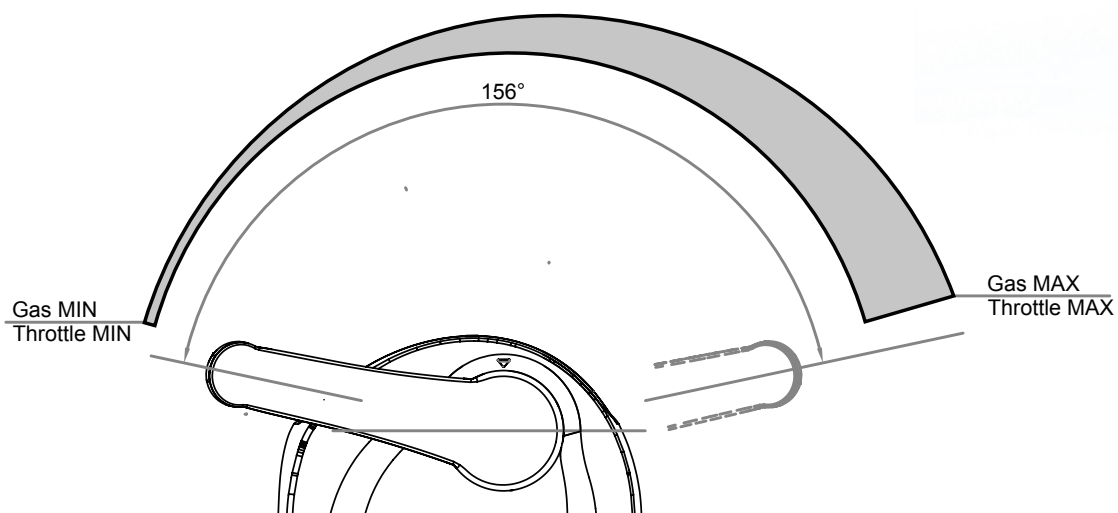

Funzionamento leva di comando del motore (colore rosso)
Functioning of the engine throttle command lever (red)

5000 Electronic control head

Electronic control systems 5000 Series combine mechatronic solutions and digital communication technologies which permit to build modular systems, flexible, reliable and easy to install



- Pure AISI 316
- Throttle/shift control on the same lever
- Fast and easy installation with plug and play functions
- Single or twin engine control
- Synchro, trolling and trim/flap built-in functions
- Interface to frequency converters for hybrid and electric propulsion systems

SINGLE ENGINE

TRIM/FLAP BUILT-IN SWITCHES



SYSTEM CONFIGURATIONS

The system configurations are classified according to the possible combinations of:

- motor types
- gearbox types
- number of engines
- number of levers
- options

SYSTEM TYPE	ID
Mechanical throttle and mechanical gearbox	MM
Electronic voltage throttle and mechanical gearbox	VM
CANBus throttle and mechanical gearbox	CM
Electronic PWM throttle and mechanical gearbox	WM
Electronic current throttle and mechanical gearbox	IM
Mechanical throttle and electronic gearbox	ME
Electronic voltage throttle and electronic gearbox	VE
CANBus throttle and electronic gearbox	CE
Electronic PWM throttle and electronic gearbox	WE
Electronic current throttle and electronic gearbox	IE
Electronic voltage throttle and trolling gearbox	VT
CANBus throttle and trolling gearbox	CT
Trim/Flap option	F

4500 WRC

Wireless remote control

4500 Wireless Remote Control allows you to perform, with safety and precision, low-speed maneuvers such as docking, anchoring or mooring from the most convenient position of your boat

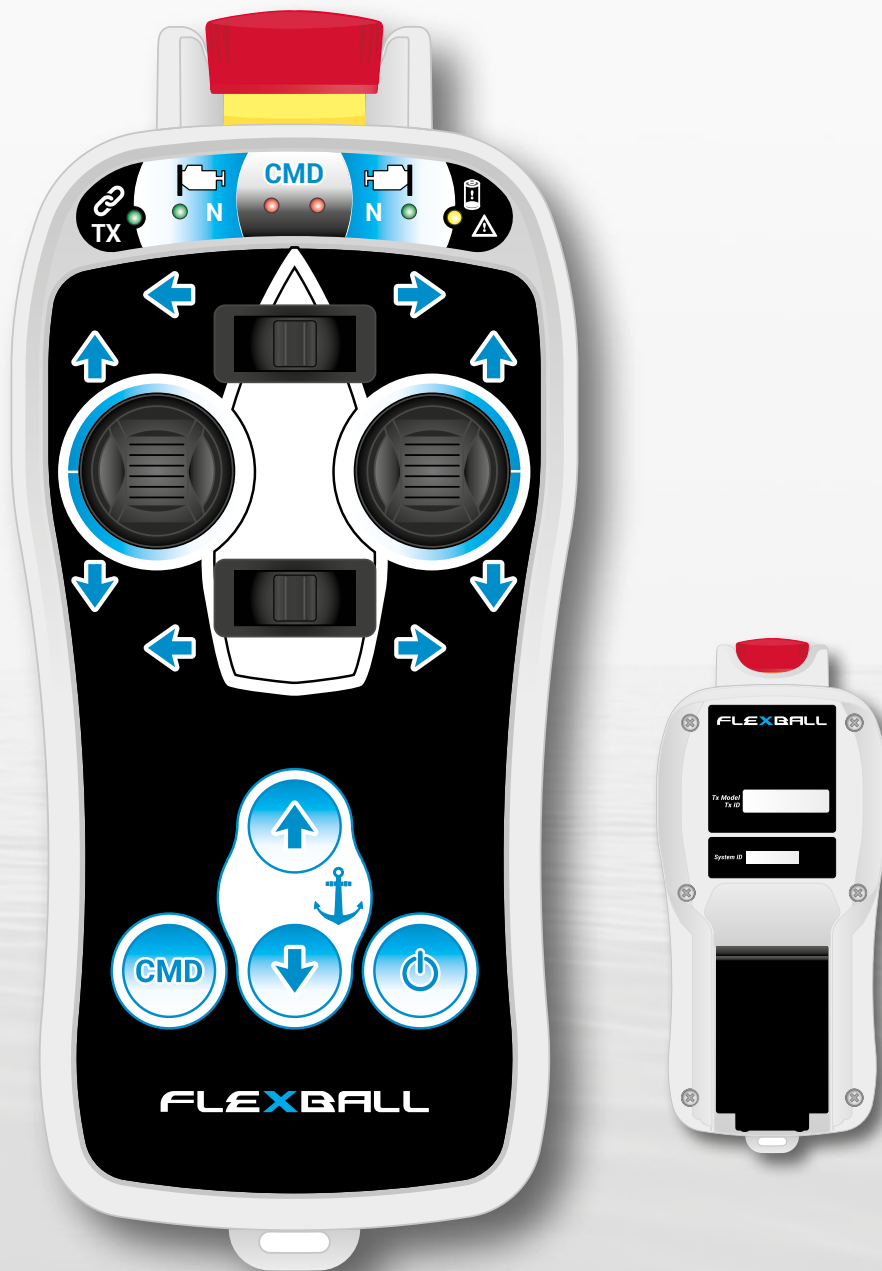

Available configurations

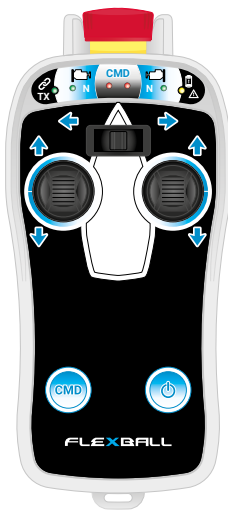

WRC 3F

- PORT ENGINE
- STARBOARD ENGINE
- BOW THRUSTER

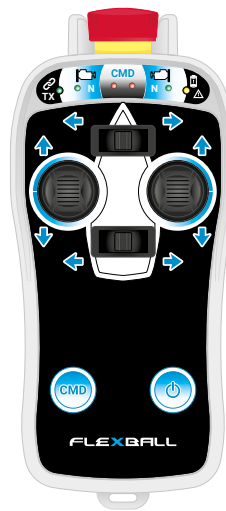

WRC 4F

- PORT ENGINE
- STARBOARD ENGINE
- BOW THRUSTER
- STERN THRUSTER



WRC 5F

- PORT ENGINE
- STARBOARD ENGINE
- BOW THRUSTER
- ANCHOR WINCH



WRC 6F

- PORT ENGINE
- STARBOARD ENGINE
- BOW THRUSTER
- STERN THRUSTER
- ANCHOR WINCH

TECHNICAL DATA

- Dimensions (L.W.A.) 157 x 80 x 44 mm
- Casing material Charged Nylon UL 94 HB
- Degree of protection IP 65
- Weight (battery included) ≈340 g max
- Operating and storage temperature -25°C - +70°C / -40°C - +85°C
- Operating frequency I.S.M. 2.4 GHz, 16 ch
- Number of programmable channels 16
- Transmission Mode Half Duplex
- Autonomy at 20°C ≈18 hours

SUPPLY KIT

- 1 TRANSMITTING UNIT
- 1 RECEIVER UNIT
- 2 RECHARGEABLE LI-ON BATTERY
- 1 BATTERY CHARGER
- 1 USER MANUAL

4500 WPP

Wireless portable panel

4500 Wireless Portable Panel allows you to perform, with safety and precision, maneuvers such as docking, anchoring and mooring, both at idle and higher adjustable speed



- Permanent coded radio link between the transmitter and the receiver
- Emergency stop button which brings back all the commands to a safety status
- Interference-free response in less than 100ms
- 100 m range
- IP 65
- Some functions of deck control station are available wherever aboard

The installation of the 4500 WPP doesn't modify in no way the existing control station functionality and layout. It offers you the further possibility to maneuver the boat and adjust rpm moving freely, from bow to stern, increasing your field of vision if compared to the usual stationary control station.

The enclosure made of shock-resistant plastic material withstands the most

severe conditions of use, maintaining over time complete reliability and functionality.

The radio remote control is designed and built in compliance with European Directives and European Standards and it is suitable for creating a wireless control station which satisfies the highest levels of safety.



• Size (L x D x H)	205 x 150 x 150 mm
• Weight (battery included)	Max. @1.450 g
• Range	100 meters
• Case material	Loaded nylon UL94 HB
• Battery	NiMH 3,6 V - 2,2 A/h
• Battery autonomy at 20°C with charged and continuously operated battery	@22 hours
• Low battery level advance warning time	@15 min
• 1 STOP command	(ISO 13849-1:2006 6.2.7 architecture) PL e, Category 4 / SIL 3
• Buzzer	Internal
• Operating temperature	-25°C ÷ +70°C
• Storage temperature	-40°C ÷ +85°C
• Power supply	Single battery
• Radio transmission	Double
• LEDs	Link TX, Link RX, Error code
• Protection class	IP 65



Notes

A series of horizontal dotted lines for writing notes, spanning the width of the page.



FLEXBALL
ITALIANA

WR CONTROLS GROUP



Flexball Italiana S.r.l.
Via San Luigi 13/A
10043 - Orbassano (To) Italy

Tel +39 011 9038900
info@flexballitaliana.com
www.flexballitaliana.com

